

# RADICAL FUTURES

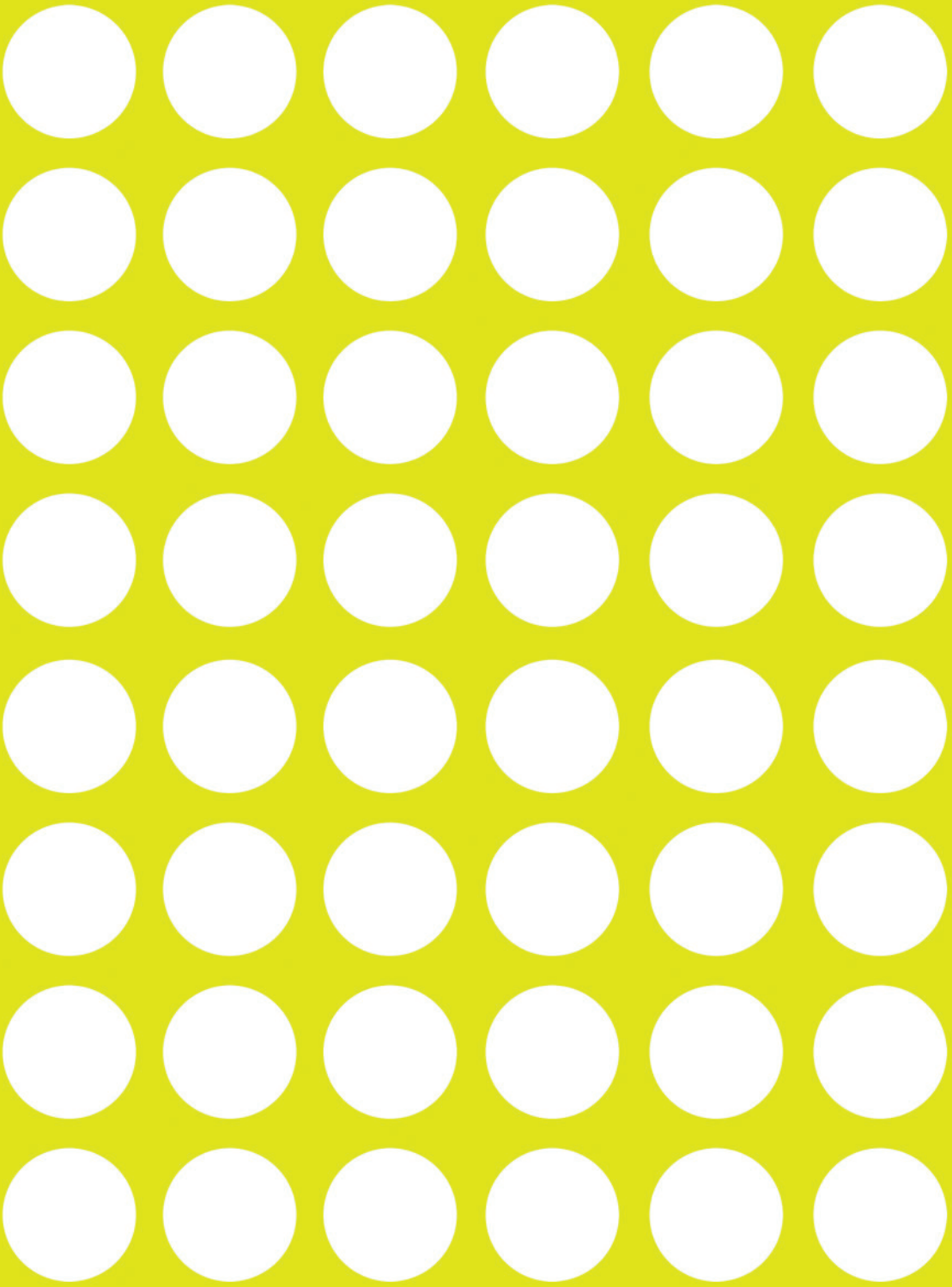

UOU Scientific Journal  
Issue #08 December 2024  
ISSN: 2697-1518  
DOI: 10.14198/UOU.2024.8

Journal #08 UOU scientific journal #08  
UOU scientific journal #08 UOU scie



# UOU scientific journal

## Issue #08/RADICAL FUTURES

### December 2024

#### Guest Editor

Miguel Luengo Angulo / Universidad Europea de Madrid, Spain

#### Associate Editors

Joaquín Alvaro Bañón / Alicante University, Spain  
 Michael Devereux / University of the West of England (UWE) Bristol, UK  
 Sarah Stevens / University of Brighton, UK  
 Charlotte Erckrath / Bergen School of Architecture, Norway  
 Anna Moro / Politecnico di Milano, Italy  
 Marco Bovati / Politecnico di Milano, Italy

#### Editorial Director

Maria Luna Nobile / UMA Umeå University, Sweden

#### Graphic Editors

Ana Flensburg, Alexia Coscolín, Lucía Manchón, Miguel Luengo Angulo,  
 Maria Luna Nobile, Javier Sánchez Merina

#### Editor-proofreaders

Mike Devereux / UWE Bristol, UK  
 Trevor Garnham / Honorary Fellow of Kingston University, UK  
 Sarah Stevens / University of Brighton, UK

#### Editor-in-chief

Javier Sánchez Merina / Alicante University, Spain

Department of Graphic Expression, Design and Projects  
 Escuela Politécnica Superior  
 ALICANTE UNIVERSITY  
 Carretera San Vicente del Raspeig s/n, 03690 San Vicente del Raspeig.  
 Alicante, SPAIN

ISSN: 2697-1518

DOI: 10.14198/UOU.2024.8

<https://revistes.ua.es/uou>  
[uou@ua.es](mailto:uou@ua.es)

#### Scientific Board

Agustina Martire / Queen's University Belfast, United Kingdom  
 Alessandra Swiny / University of Nicosia, Cyprus  
 Andreea Calma / Universitatea Ion Mincu, Romania  
 Angela Kyriacou Petrou / University of Nicosia, Cyprus  
 Anna Moro / Politecnico di Milano, Italy  
 Antonio Esposito / Università di Bologna, Italy  
 Arturo Romero Carnicero / Karlsruher Institut Für Technologie, Germany  
 Beatrice Jöger / "Ion Mincu" University of Architecture+Urbanism, Romania.  
 Catalina Morales Maya / UWE Bristol, UK  
 Charlotte Erckrath / Bergen School of Architecture, Norway  
 Doina Carter / University of West London, UK  
 Eva Luque / Universidad de Sevilla, Spain  
 Ferran Grau Valldosera / Universidad Rovira i Virgili, Spain  
 Franka Jagielak / Pedagogical University of Cracow, Poland  
 Grazia Pota / Università di Napoli Federico II, Italy  
 Heiner Stengel / IUBH Internationale Hochschule, Germany  
 Hocine Aliouane-Shaw / ENSAP Bordeaux, France  
 Ingrida Povilaitiene / Kaunas University of Technology, Lithuania  
 Jaime Montes Bentura / KTH School of Architecture, Sweden  
 Jane Coulon / ENSAM Reunion Island, France  
 Javier Sánchez Merina / Alicante University, Spain  
 Jerzy Łątka / Wrocław University of Science and Technology, Poland  
 Joanna Dudek / Politechnika Rzeszowska, Poland  
 Joaquín Alvaro Bañón / Alicante University, Spain  
 José Antonio Carrillo Andrada / American University in Dubai, UAE  
 José Lage / Porto University, Portugal  
 Marcin Kolakowski / University of Lincoln, UK  
 Marco Bovati / Politecnico di Milano, Italy  
 Maria Hadjisoteriou / University of Nicosia, Cyprus  
 María José Pizarro / Universidad Politécnica de Madrid, Spain  
 Maria Luna Nobile / UMA Umeå University, Sweden  
 Marie Kraft / Malmö University, Sweden  
 Markella Menikou / University of Nicosia, Cyprus  
 Martina D'Alessandro / Università di Bologna, Italy  
 Mauricio Morales-Beltran / Yaşar Üniversitesi, Türkiye  
 Miguel Luengo Angulo / Universidad Europea, Spain  
 Mike Devereux / UWE Bristol, UK  
 Ozan Avci / MEF University Istanbul, Türkiye  
 Paola Scala / Università di Napoli Federico II, Italy  
 Raffaele Errichiello / UMA Umeå University, Sweden  
 Salah Haj Ismail / Ankara Aybu University, Türkiye  
 Sarah Stevens / University of Brighton, UK  
 Sofia Aleixo / Universidade de Évora, Portugal  
 Szabolcs Portschy / Budapest University of Technology, Hungary  
 Thomas Loeffler / University in Cairo, Egypt  
 Tomas Ooms / KULeuven Campus Sint-Lucas Brussel/Gent, Belgium  
 Valerio Morabito / Studi Mediterranea di Reggio Calabria, Italy  
 Won-joon Choi / Soongsil University, South Korea  
 Yianna Moustaka / London South Bank University, United Kingdom  
 Yiorgos Hadjichristou / University of Nicosia, Cyprus

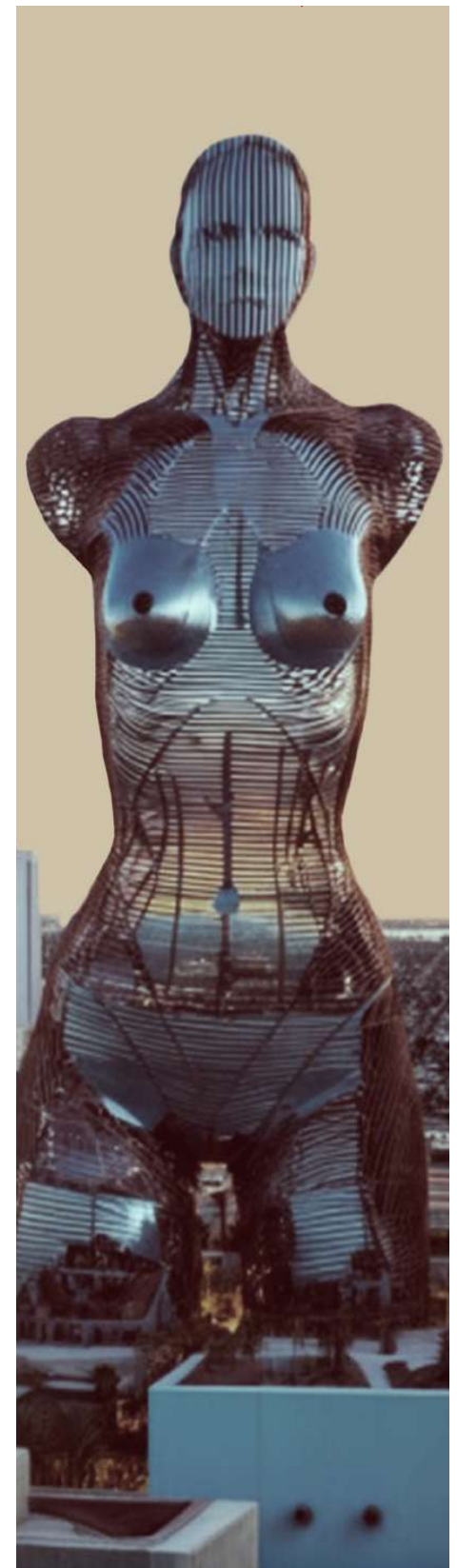

All manuscripts submitted to the UOU scientific journal have been reviewed by the Editorial Committee, which approved the academic quality, format and publication standards.

The scientific articles included in **RADICAL FUTURES** have been **double-blind peer-reviewed** by external evaluators, chosen by the Editorial Board from among experts in the relevant fields of study.

## table of contents

<b>LETTER FROM THE DIRECTOR</b>		
<b>The radical notion of Error</b>	6	
<i>Javier Sánchez Merina</i>		
<b>EDITORIAL</b>		
<b>Radical /rædikl/</b>	16	
<i>Miguel Luengo Angulo</i>		
<b>Radical Future (simple, continuous, perfect or perfect continuous)</b>	22	
<i>A conversation between the Editorial Committee members: Maria Luna Nobile, Mike Devereux, Joaquín Alvado Bañón, Sarah Stevens, Marco Bovati, Anna Moro - with Miguel Luengo Angulo</i>		
<b>A conversation with Jarauta</b>	26	
<i>Francisco Jarauta, Miguel Luengo Angulo</i>		
<b>RADICAL DEFINITIONS</b>		
<b>The Italians do it Better!</b>	34	
<i>Scala, Paola</i>		
<b>Was Skarphédinn Jóhannsson a Radical Architect?</b>	42	
<i>Arnardóttir, Halldóra</i>		
<b>RADICAL URBANISM</b>		
<b>Oswald Mathias Ungers in Berlin</b>	54	
<i>D'Alessandro, Martina</i>		
<b>RADICAL SCALES</b>		
<b>Restoring Porosity in Greater Cairo through Architectures without Architects</b>	68	
<i>Carandente, Alberta</i>		
<b>AIRBORNE, MULTISENSORIAL AND PSYCHOLOGICAL ARCHITECTURE</b>		
<b>Radicalism and Freedom in Low-tech Architecture</b>	80	
<i>Kolakowski, Marcin Mateusz</i>		
<b>Forgetting Acceptances</b>	92	
<i>Pinar Akin, Ayse Tugce</i>		
<b>ARCHITECTURE, URBAN PLANNING AND ART</b>		
<b>The Radicality of Use</b>	104	
<i>Cardini, Roberto Juan</i>		
<b>Radical Devices</b>	116	
<i>Nobile, Maria Luna; Melina, Francesca</i>		
<b>RADICAL TECHNOLOGY</b>		
<b>The Architecture of Defying Gravity</b>	132	
<i>Kachaamy, Georges</i>		
<b>Transformative Technologies in Architectural Design</b>	144	
<i>Atakara, Cemil; Kalwry, Hasan</i>		
<b>RADICAL PEDAGOGIES AND EDUCATION</b>		
<b>Eco-sensitive Cyberatmospheres</b>	158	
<i>Manchón Martínez, Lucía</i>		
<b>ATLAS</b>		
<b>Radical Atlas</b>	168	
<i>Miguel Luengo Angulo; José Antonio Carrillo Andrada</i>		
<i>Students contributions:</i>		
<i>Jakob Schreiner Benito, Nina Méndez Bisgaard, Micheline Bood, Mads Hvidkær Christoffersen, Valentina Andrade, Valentina Scampini, Elisa Merchán, Juan Pablo Díaz Hernández, Adam Ihab, Celeste Ortez, Camila Gómez, Fernando Salinas, Mariapaula Vigo, Andrei Constantinescu, Kenza Nakhli, Javier Prados, Rania Melehi Loudiyi, Ciro Ramírez, Racse Ramos, Sophia Obando, Raquel Vidales, Helen González, Silvana Torin, Lucía Callatopa, Mara Van Vliet, Zoia Dolgova, Aneta Báčová, Lucia Strýčková, Selina Untermair, Yasmine El Bada, Franz Schubert, Aron Schönfeld, Esther Oliver Marín, Gadea Vicente Caravaca, Noah Pashkevich, Max Darwall, Leonhard Sigmund, Nina Lüdtke</i>		
<i>Call Radical Statement:</i>		
<i>Artistic contribution - Emanuele Quinz; Marco Pace</i>		
<i>Student Contribution - Mads Hvidkaer Christofersen and George Azer</i>		
<b>Tabarca: A Planetary Indigestion</b>	194	
<i>Javier Sánchez Merina, Joaquín Alvado Bañón</i>		



# The radical notion of Error

Letter from the director

**In the years following the pandemic, it appears that many of us have consigned its memory to oblivion, as if it never occurred. Yet, that transformative period presented an opportunity to envision a new approach to learning, UNIVERSITY of Universities: one that embraces differences, fosters collaboration, grants students' freedom of choice, nurtures horizontal relationships, and seeks spaces where genuine knowledge is cultivated.**

**With each new semester, I find myself questioning whether the extraordinary experiences of that time belonged only to a fleeting moment - a transient pause in our fast-paced routines. However, beyond our UOU workshops, which form the foundation of our collaboration, there remains a wealth of collective experiences generated this very year. It may now be time to move beyond questioning the necessity of UOU and instead adopt it as an enduring attitude - a way of learning and living architecture.**

## A YEAR OF COLLECTIVE PRACTICES

This year has been a testament to the vitality of our UOU initiatives:

- Sofia and João (Évora) curated a remarkable exhibition showcasing the results of their UOU workshop co-directed by Luz, Eva, and José (Seville).
- Alberto and Beatriz (Porto), after leading their online workshop, travelled to Alicante for the final critique

and festival - a vibrant gathering where Alberto, acting as an Erasmus teacher, worked directly with his REAL international students (Fig.1).

- Similarly, Szabolcs (Budapest) visited Alicante for the festival, fostering camaraderie over several memorable paellas.

- Miguel (Madrid), meanwhile, prepared this new issue of the UOU scientific journal, RADICAL FUTURES, which is now gaining recognition in many countries, Mexico the most recent one.

- Precisely in Mexico, architecture students at UNAM, encouraged by Claudia (Mexico City), are requesting online courses from professors abroad, blending local instruction with international collaboration.

- The rich cultural exchange continued during a collaborative critique involving students from Mexico, Morocco, and Alicante, with Wafae (Fès) joining as a new UOU partner.

- An article in this issue of the journal details the work undertaken on Tabarca Island with Joaquín (Alicante) and ERASMUS BIP students. Preparations are already underway for the next workshop, focusing on the legal rights of a river in Belgium as an ecosystem with 'personhood,' co-directed with Christine (Louvain), Jane (La Réunion), and Arturo (Karlsruhe).

- The EURAU congress, organized by Marco, Anna, and Daniele (Milan), featured contributions from a diverse array of UOU participants: Angela, Yiorgos, Maria, Alessandra (Nicosia), Beatrice (Bucharest), Paola (Naples), Hocine (Bordeaux), Ozan (Istanbul) and Luna (Umeå), the organizer of the next EURAU.

- The ProtoLAB Summer School in Poland, led by Jerzy and Agata (Wroclaw), remains a hub of experimentation, with participants such as Mauricio (Izmir), Doina (London), Raffaele (Umeå), and Salah (Ankara) pushing the boundaries of design and materials.

Sánchez Merina, Javier<sup>1</sup>

<sup>1</sup> Department of Graphic Expression, Design and Projects, Alicante University, Spain.  
<https://orcid.org/0000-0003-1973-690X>  
 jsm@ua.es

Citation: Sánchez Merina, J. (2024). "The radical notion of Error", UOU scientific journal #08, 6-13.

ISSN: 2697-1518. <https://doi.org/10.14198/UOU.2024.8.01>  
 This document is under a Creative Commons Attribution 4.0 International license (CC BY 4.0)

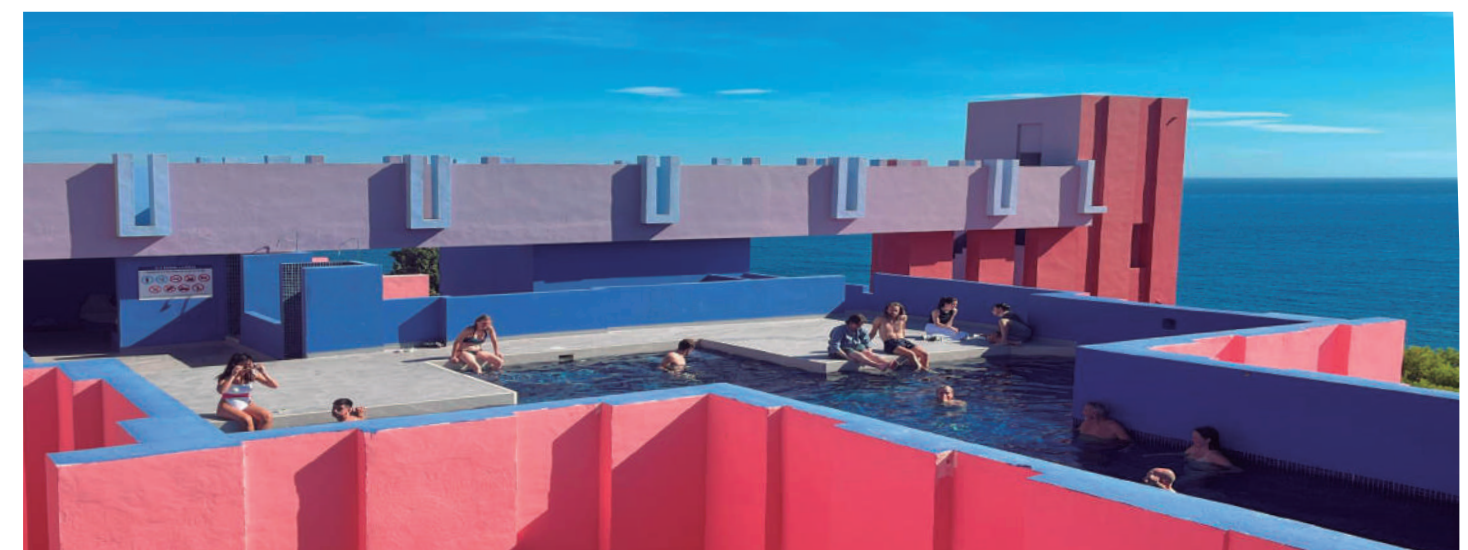

Fig.1 - Experiential crit with Alberto and Beatriz in *La Muralla Roja*, by Ricardo Bofill (Calpe, Alicante).



## A PROTO LAB PERSONAL EXPERIENCE

In this introductory letter to the current issue of the journal, I aim to argue for the radical condition of our collective practices, drawing upon my experiences at ProtoLAB.

In the summer of 2022, I participated in this remarkable summer course in Poland for the first time. ProtoLAB, led by Jerzy, was structured into two distinct phases. The first phase was conducted online, where students were organized into groups tasked with designing and developing 1:1 scale projects. These projects emphasized social concerns and were complemented by daily lectures on building techniques. By the end of the first week, the students were required to finalize their designs and compile a detailed list of materials needed for construction.

After a one-week hiatus - during

which Jerzy and his local team of volunteer architecture students in procured the necessary materials - the second phase commenced. We convened in a vast 2000-square-meter former tram depot in Wrocław, where all materials were meticulously organized. A lorry loaded with MAKITA tools, generously supplied by one of the workshop's sponsors, awaited us. The first day began with a safety class on the use of professional cutting tools.

As a participating instructor, I moved from group to group, assisting students with design challenges, construction methods, and assembly techniques. This methodology proved highly effective, as students assumed responsibility for their projects and managed their time to complete construction within the allocated week.

For the instructors, the process was equally enriching. The constant critique sessions fostered a collaborative learning environment

where we learned from one another. Yet, for me personally, the experience presented a unique challenge. As someone who greatly enjoys crafting my designs by hand, I found myself envious of the students' hands-on engagement. To address this, I utilized spare moments to create a series of small, personal projects, which I later gifted to participants.

Each day brought unexpected tasks that reflected the dynamic nature of the workshop:

**- The First Day:** We encountered a logistical challenge with the WUWA café, a historical institution built in 1929 as part of the modernist movement. The café's opening hours clashed with the workshop's schedule, making it difficult to begin work without a proper coffee and snack. To resolve this, we convinced the café owner to open earlier in exchange for a custom-designed serving tray. The design celebrated the laminated wood's natural patterns and incorporated specific diameters to accommodate

cups and plates, thus blending functionality with aesthetic appeal (Fig.2).

**- The Second Day:** A student approached me with a request to create a tool to simplify the application of glue onto cardboard panels, a method inspired by Shigeru Ban's designs for Ukrainian war refugee housing. Despite the extensive range of MAKITA tools available, none served this specific purpose. I crafted a custom tool, humorously branded in MAKITA's characteristic blue colour and logo, which quickly became a highlight of the workshop's creative improvisation (Fig.3).

**- The Third Day:** A ProtoLAB tradition is to host a multicultural dinner and celebration. Participants prepared dishes from their home countries, with our group contributing two types of paella. To honour Jerzy, the evening culminated in presenting him with a custom-made cardboard helmet, humorously dubbed "Captain Cardboard," which has since

become a cherished token among his accolades (Fig.4).

**- The Fourth Day:** Students began to see ProtoLAB as an opportunity for bespoke designs. One requested a ring to gift her boyfriend as a subtle encouragement for deeper commitment.

The result was a MAKITA inspired aluminium ring engraved with the letter "M," coinciding with the Polish initial word for love, *Miłość*. This simple yet meaningful gesture highlighted the workshop's blend of creativity and personal significance... and it worked! (Fig.5).

**- The Last Day:** For the final exhibition, a group that had constructed a portable tearoom needed a modular table for their tea ceremony. The design challenge was to ensure portability while accommodating eight people. Built in wood and painted in blue, the resulting MAKITA table was composed of four interlocking sections just secured by a tensioned cord. The yellow cord served as a

tribute to the Ukrainian students participating in the course, underscoring the emotional resonance of the workshop (Fig.6 and 7).

## THE EVOLUTION OF ENGAGEMENT

My second year at ProtoLAB marked a significant departure from the previous experience. Jerzy introduced a new structure wherein each instructor became the dedicated tutor of a single group. This shift fostered deeper engagement with a specific project, but it came at the cost of the collaborative freedom that had characterized my first year.

On the positive side, this new approach encouraged a more horizontal relationship between instructors and students. As tutors, we were not only ideators but also implementers, responsible for translating our concepts into reality. This dynamic required careful consideration of the feasibility and



Fig.2 - WUWA tray.



Fig.4 - Captain Cardboard helmet.



Fig.3 - MAKITA spatula.

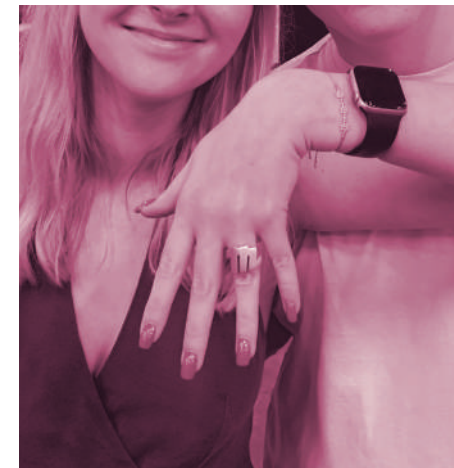

Fig.5 - MAKITA ring.



Fig.6 and 7 - MAKITA portable table.



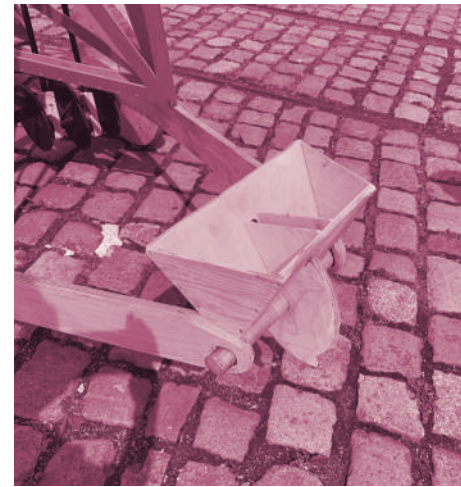
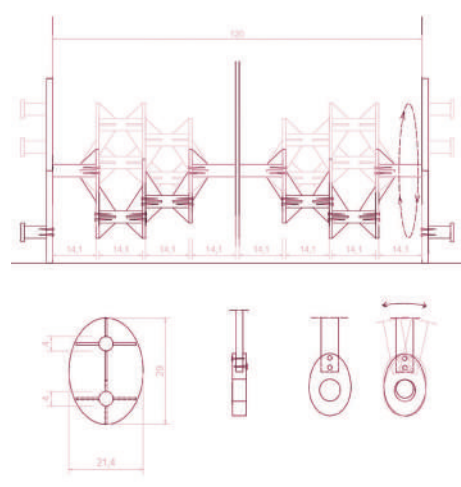

Fig.8 - The dragon pulled by children. practicality of our guidance, adding a layer of accountability to our roles.

My group was tasked with designing a pavilion for children, intended to be constructed in the garden of a castle. Our discussions often culminated in the same realization: static architecture might not captivate children's imaginations. This insight led us to embrace a childlike perspective, exploring how architecture could possess magical and dynamic

Fig.9 - Wooden crankshaft mechanism. qualities.

Our final proposal was an architectonic dragon - a mobile, interactive structure animated by the participation of children. The dragon was designed to be pulled by children, and in its movement, it planted tree seeds, as a transformation of urban spaces (Fig.8).

The project presented several challenges. The first step involved mastering the principles of origami

to conceptualize the dragon's form. From there, we translated this into wood construction, incorporating a crankshaft mechanism to animate the dragon's wings.

Predictably, the wooden crankshaft broke during testing, necessitating multiple iterations to achieve a functional design (Fig.9). We eventually complemented the structure with a frontal cogwheel mechanism that facilitated the planting process. As the dragon

moved, the cogwheel created holes in the ground, allowing seeds to drop from a storage box, effectively combining whimsy with ecological purpose (Fig.10).

The culmination of our efforts was captured in a poignant image of children parading the dragon around the castle grounds in Wrocław (Fig.11). This parade has since become a cherished tradition, with the dragon now housed in the castle's basement, its new permanent home.

This experience underscored the importance of integrating imagination and play into architectural practice. By thinking as children, we were able to envision an architecture that not only delighted but also engaged with pressing environmental concerns.

The dragon now stands as both a testament to the power of collaborative creativity and an enduring symbol of ProtoLAB's innovative spirit.

## SUMMER 2024 AND THE VALUE OF ERROR

The summer of 2024 marked the last ProtoLAB, a moment that naturally prompted introspection about our roles as educators. While the students were new, the recurring nature of the workshop led me to question how we, as teachers, could continue to bring fresh insights and challenges to the experience.

In a conversation with Jerzy, I came to appreciate the extraordinary atmosphere he had cultivated at ProtoLAB - an environment grounded in creativity, "learning by doing," and, more importantly, "learning by errors." Few institutions, including universities, truly value error as a constructive force. On the contrary, errors are often stigmatized, seen as failures rather than as opportunities. At ProtoLAB, however, errors are not only tolerated but welcomed. This perspective fosters an unparalleled

learning experience, empowering participants to take risks, explore the unknown, and embrace the intuition that often leads to groundbreaking discoveries.

One personal epiphany emerged during the construction of the dragon project the year before. Observing the strength of adhesives over the wood itself, I began experimenting with laminated wood. While traditional methods of lamination require complex technologies like presses and molds, I sought an alternative approach. Inspired by Antoni Gaudí's use of natural catenary curves in the arches of the Sagrada Família, I proposed creating a new form of plywood by layering and curving thin, 4 mm plywood panels. By combining three panels, curving them according to their natural tendencies, we developed a 12 mm material - without the use of molds (Fig.12 and 13).

To test this innovation, we set ourselves an ambitious goal: to construct a boat. A boat presents a



Fig.11 - Festival of children in Wrocław.



Fig.12 and 13 - Experimenting with plywood panels.





Fig.14 - Testing the structure with the telescopic components.

unique and rigorous architectural challenge, requiring not only strength and durability but also floatability, usability, and aesthetic considerations. This exercise would be a comprehensive lesson for architects and a celebration of ProtoLAB's experimental ethos.

Our boat, measuring six meters in length and capable of accommodating seven people, was realized through the collaborative efforts of an international team:

- Romance Al Sous  
UCLouvain
- Talha Ulaş  
Ankara Yıldırım Beyazıt University
- Tuğçe Ustaoglu  
Ankara Yıldırım Beyazıt University
- Awa Trawally  
Ankara Yıldırım Beyazıt University
- Dominik Gromek  
Wroclaw Univ. Science & Technology
- Guided by Joaquín Alvaro Bañón  
Alicante University

The project also aimed to participate in the 49th edition of the *Vogalonga* in Venice, an event where more than 2,000 rowing boats converge on the Grand Canal to honour traditional navigation techniques and advocate for sustainable practices to protect Venice from wave damage.

To qualify for this event, we needed to ensure the boat was transportable. Thus, we designed it as a telescopic structure, with pieces that could be disassembled for travel (Fig.14). This added another layer of complexity, requiring solutions for both structural integrity and watertightness. We devised a tongue-and-groove system, where the two outer panels were longer than the inner one, effectively creating a sandwich structure. We also leveraged the natural expansion properties of wood when exposed to water, which sealed the joints and ensured buoyancy.

As well we tested the boat in one of Wroclaw's many canals. It floated - but too much! (Fig. 15, 16 and 17). The boat's light structure made its weight negligible compared to our

bodies. This imbalance resulted in instability, a problem that required further study of key principles such as the centre of gravity, centre of buoyancy, centre of flotation, vertical centre of buoyancy (VCB), longitudinal centre of flotation (LCF), and longitudinal centre of buoyancy (LCB). After analysing these principles, we resolved the

issue with the addition of a bulb keel. This solution provided the necessary counterweight, lowered the centre of gravity, and stabilized the boat, ensuring it would perform as intended.

None of this would have been possible without the ProtoLAB environment, where permissible

error allowed us to iterate, break materials during testing, and refine our ideas through failure. Jerzy Latka's approach nurtures not only creativity but also resilience and innovation, proving that risk and experimentation are the true engines of learning.

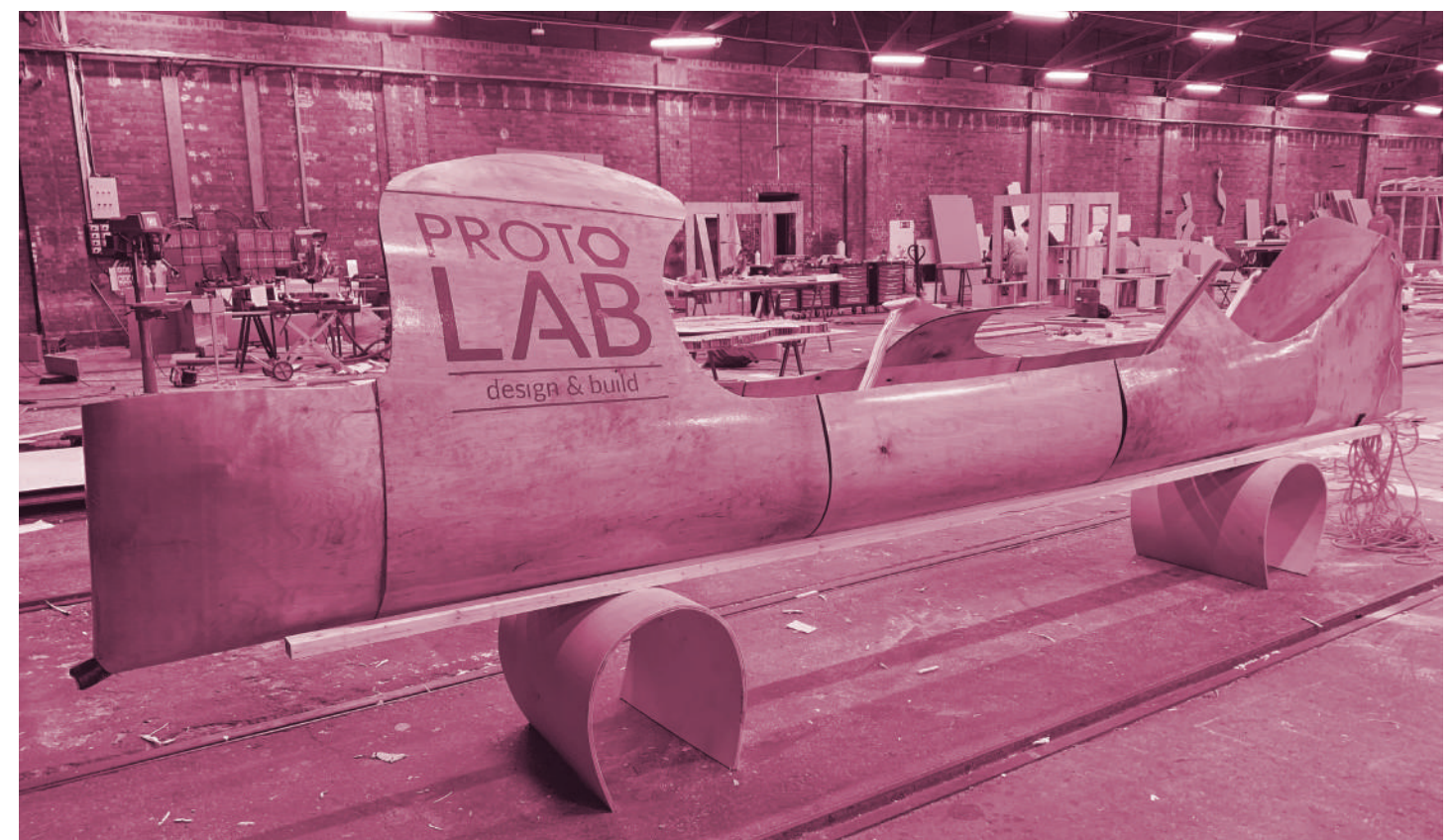
Fig.15, 16 and 17 - ProtoLAB boat ready to travel to the *Vogalonga* in Venice.



# EDITORIAL

# Radical /Rædikl/

Adjective [usually before noun]: Relating to the most basic and important parts of something; complete and detailed

Radical architecture explored, with significant differences, the idea of the performative environment that surrounded us (and that we were also assembling) combined with the impact of that environment in our lives (big word that could be divided into social, cultural, political, artistic, psychological, physiological, behavioral components...etc.).

The presence of another big word such as air is relevant to the radical constellation because this combination of gases, essential condition for terrestrial life and made up of 21% oxygen, 78% nitrogen, 0.93% argon and 0,035% carbon dioxide<sup>1</sup> just made it happen with a very discreet presence (or consciousness) as if something that we just take for granted. And yet we shouldn't, because from ordinary poor conditions like when it smells bad, gets uncomfortably cold or hot to lethal diversions such as nuclear radiation or an airborne virus like COVID-19 proved how viciously wrong we are.

Radical architects figured a brilliant move: Architecture could be used to expose OUR problems, real and big issues in order to highlight and expand them so they became so HUGE as to necessarily see them... and eventually confront them.

Their task was not to solve anything at all, they were architects... but their critical understanding of our discipline formulated some of the theoretical tools that we're using now. As Hans Hollein stated "Everything is Architecture" and most likely (check Francisco Jarauta's interview) we need that set of magnifying glasses to illustrate again (that's our job, at the end of the day) the dark clouds right above us, being political most of them and that war, racism, social and economic inequality plus solving the pollution of our natural atmosphere aka global warming can (again) no longer be extended.

## THE CALL

The shape of a city changes faster, alas! than the heart of a mortal (Baudelaire, 1991)

Radical Architecture is, according to Maigayrou, a "current of research less concerned with the practice of the architectural profession than with reflecting on the bases, the foundations of architecture"<sup>2</sup> and we can identify it (in the current dizzying world of instant consumption of images) with projects such as the Pneumacosmos (Haus Rucker Co, 1967), the Continuous Monument (Superstudio, 1969) or the No Stop City (Archizoom, 1970).

This represents a fleeting but energetic period that was essentially deployed in Europe between the years 1960 and 1975 with the purpose of thinking about the architectural discipline from its origin (hence its essential, fundamental nature), displacing the understanding of the craft from the architect's routine as a builder towards the expanded territory of reflection on the world and the architect's competence to interpret it and act in it.

To this heterogeneous movement belongs a generation distanced from modernity and without direct involvement in the Second World War but located in the complex morass of a post-industrial world identifiable with production and communication on a planetary scale; a scenario of change and suspicion that legitimizes the end of all idealistic vision, the fall of the optimistic and teleological modern project for the advent of the real with its contradictions and defects.

Radical projects manifest this confusion in practices that are rarely "constructive" but transgressive, critical, and committed. Sometimes legible from the nearby world of the second artistic avant-garde (Pop Art, Minimalism, Land Art, Performance Art...), political-social criticism, the mediation of the body or environmental concern and activism. All of this is intended to confront the world they've received by making its paradoxes visible and revealing the absurdity of a discipline that continues to insist on defining itself from formal and stylistic aspects to deviate towards a factual, operational architecture

that acts on the real... even if it does not build anything (especially not building anything).

Radical Futures aims to achieve a contemporary understanding of this critical mindset, extend the limits of radical architecture and urbanism, and embrace the emergence of new practices supported by unconventional approaches from design, urbanism and technology. This Call for Papers invites authors to re-connect architecture and criticism, understanding their theoretical borders from within the discipline. Nonetheless, interdisciplinary expressions and research through the proposed but not limited "radicalism" and keywords listed below:

### 1. Radical definitions

- a) The relationship between architecture and critical thinking
- b) What is the purpose of architecture?
- c) Non-buildable architectures (for our own good)
- d) Indiscipline as a radical strategy

### 2. Radical urbanism

- e) City, symbolism, and representation
- f) Non-buildable cities (for our own good)
- g) Contemporary radical cities or: Is radical urbanism possible today?
- h) Contemporary Supersuperficies

### 3. Radical scales

- i) S, M, L y XL cities
- j) Appliance architecture
- k) Radical furniture design
- l) Utopian and dystopian architecture

### 4. Airborne, multisensorial, and psychological architecture

- m) Inflatables and playful devices
- n) Contemporary Mind expanders
- o) Temporary radical structures
- p) Performative architecture

### 5. Architecture, urban planning, and art

- q) Radical urban art
- r) Radical collages
- s) Contemporary Restless spheres
- t) Playful devices

### 6. Radical Technology

## Luengo Angulo, Miguel<sup>1</sup>

<sup>1</sup> Universidad Europea de Madrid, Escuela de Arquitectura, Ingeniería y Diseño, Madrid, Spain.  
<https://orcid.org/0000-0002-3758-0040>  
 miguel.luengo@universidadeuropea.es

Citation: Luengo Angulo, M. (2024). "Radical /Rædikl/", UOU scientific journal #08, 16-21.

ISSN: 2697-1518. <https://doi.org/10.14198/UOU.2024.8.02>  
 This document is under a Creative Commons Attribution 4.0 International license (CC BY 4.0)



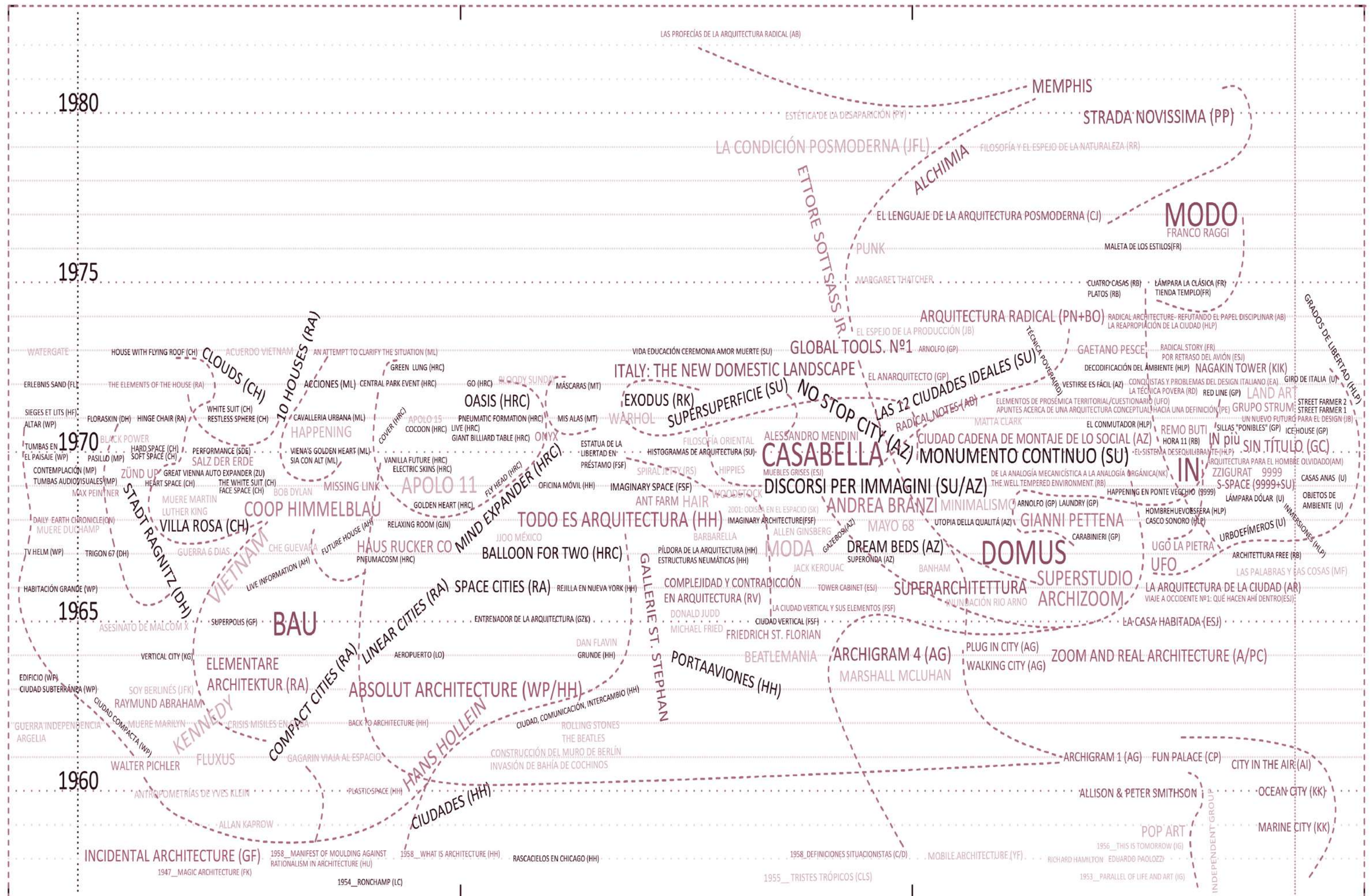



u) Artificial Intelligence, VR / MR / AR / XR / Metaverse / NFT / Web 3.0 for radical technology

v) New software applications to radical concepts

### 7. Radical pedagogies and education

w) Student radical approaches to architecture and urban planning

x) New conceptual pedagogies for a radical education

## THE ARTICLES-ESSAYS

### Radical definitions

In the first article, **“The Italians do it better! A contemporary interpretation of the radical movement”** we find a critical reevaluation either nostalgic or proactive of the Italian radical movement, seeking to rebuild their differences and theoretical contributions. Also, to analyze the reasons behind the present resurgence of interest in these movements and to check how they were acknowledged by contemporary critics. The author reminds us that: “nemo propheta in patria” - indeed, Italian radical architects were often perceived by the Italian critics, best case scenario, as provocateurs or, at worst, as marginal figures who, instead of engaging in tangible change, lost themselves in utopian or dystopian visions... as if that wasn't important.

As Beatriz Colomina put it: What does it mean for young architects and scholars to look so closely today to some short-lived experiments by young designers forty years ago? Is this a kind of nostalgia for an early phase of radicality? Or even nostalgia for an earlier phase of the global, when the very idea of resources and tools was redefined in the face of new technologies and a new awareness of planetary ecology? Are we in another phase of retooling the disciplines of design, a kind of echo of a too quickly forgotten historical moment? Is this book about the past or the future?»

In the second article, **“Was Skarphéðinn Jóhannsson a radical architect? If so, in what sense?”** the author analyses the Icelandic architect's proposals as

to be considered radical or, on the contrary and together with fellow architects, modernising the country and responding with his architecture to raise society. In this context, it will be theorized that Skarphéðinn created typologies that were radical in ways based on relative values and guidelines of redefining architecture through culture, society and nature. The author will explain how cultural anthropology, physical character, environmental and social relations, and culture are part of the architectural project as to be labeled and tagged as genuinely radical.

What architects do is radical of what architects don't want to do is what really defines this movement? This could also be a further interpretation of the article.

### Radical urbanism

In the third article, **“Oswald Mathias Ungers in Berlin: Research, project and experimentation”** the aim of the contribution is not to discuss this topic as an object of historical research but to outline the general and important aspects of Ungers' research on the city, within which the reflections on Berlin are located, underscoring the main factors that influenced the origin of the idea of the city as an archipelago. On the other hand, this contribution will revisit the concept of the city as an archipelago with the belief that it can still serve as a meaningful tool for constructing new design narratives for today's cities.

The city is at the core of Radical Architecture, the urban environment is the perfect ring where this movement thrived and boxed, and OMU developed a certainly radical way of relating with this realm. The author's research on the topic proves how Ungers deserves to be included in this group.

### Radical scales

In the fourth article, **“Restoring porosity in Greater Cairo through architectures without architects: The case study of the Koka pigeon tower in Garbage City”** the study explores how emerging design

technologies in contemporary architecture reshape the physical forms through the impact of transformative technologies on architectural design. Also their potential to revolutionize the built environment. This research aims to design new prospects for improving design efficiency between clients, designers, and society at large and provide insights into the transformative power of technology in shaping the future of architectural design. Advanced 3D modelling and simulation tools have revolutionized the design process, allowing architects to create virtual representations of their ideas and explore them in a profoundly realistic manner. The scale of the proposal demonstrates how this radical devices demand an expanded understanding of urbanism.

### Airborne, multisensorial and psychological architecture

In the fifth article, **“Radicalism and Freedom in Low-Tech Architecture: A Kantian Perspective”** the study explores the motivations and paradigms among prominent architects and builders involved in this movement, prioritizing minimalism, environmental sustainability, and autonomy from other more conventional systems. The research highlights the emphasis that low-tech practitioners place on individual empowerment, creativity, and ideological commitment, contrasting with mainstream architectural practices.

On the other hand, the author engages with a systematic protocol where the research diverts from the individual to the collective, from the local to the global in an ambitious quest for specific answers.

In the sixth article, **“Forgetting Acceptances: on the Productivity of Moments of Crisis in Architecture”** the study will rely on “classical” radical formats such as the pneumatic narrative (let's revisit Villa Rosa or the Pneumacosm) to push the conceptual framework forward, by focusing on a series of experimental architectures and the laboratory of Cloud 9. Consisting

of an interdisciplinary team, Cloud 9 tries to challenge global warming scenarios and achieve what is clearly a performative architecture, by blurring the boundaries between design and environment with the aid of present technological possibilities. The non-conventional systems designed by them shape the set of values generated in moments of crisis. In the result of the study, an initiative is brought to being visionary by clarifying the relationships before and after the act of forgetting.

### Architecture, urban planning and art

In the seventh article, **“The radicality of use: Practices of transformation based on the occupation and appropriation of buildings”** we'll find an “okupa” approach that was consistently delivered in historical radical practices such as Gianni Pettena, Ugo La Pietra, Gruppo 9999 and in the Austrian ring with Coop Himmelblau, Haus-Rucker-Co...etc. and the purpose of the author is to explore radicalism in contemporary architecture through an analysis of space transformation practices in the collective occupation and appropriation of disused buildings. The author states that unlike traditional architecture, which relies on abstract, preconfigured representational tools, these tactics emerge as spontaneous, bottom-up approaches, highlighting the effectiveness of group actions in the reprogramming of spaces.

In the eighth article, **“Radical devices: Rethinking Art and Architecture as forms of dissensus in urban environments”** the authors seek to use artistic and architectural practices as tools to engage city residents in an active dialogue about Common spaces just like Gianni Pettena did. Starting with a theoretical framework for locating the critical potential of art and architectural objects in public spaces (I'm thinking about the Uomouovosfera by Ugo La Pietra), in this paper the project is observed as an example of an ephemeral critical moving device, collecting and expanding the voices of the inhabitants around the city.

It aims to represent an open-ended invitation to re-think the boundaries between nature and the city, posing itself as a radical (from the latin radicalis) form of dissensus. As you will see this is not only theoretical because an experiment was conducted at the Umeå School of Architecture between March and May 2024 as part of a “Designing the Contemporary City” research group at the same University probing that the radical mindset is still applicable (if we apply it).

### Radical Technology

In the ninth article, **“The Architecture of defying gravity: An exploration of future environments that focuses on the poetics, innovation, and potential of airborne architecture”** we'll navigate through the evolution of levitating architecture as narrative of humanity's enduring aspiration to transcend the constraints of physical and environmental limitations. In the 21st century, the author states that this timeless pursuit has been reimagined through the innovative paradigm of Airborne Architecture, epitomized through the research of Gravity Defiant Architecture (GDA). This article delves into the origins, foundational principles, and transformative potential of it as to push the technology forward just like some radical agents did with a direct (not ironic therefore) perspective.

In the tenth article, **“Transformative Technologies in Architectural Design: Revolutionizing the built environment”** the author of the study will explore how emerging design technologies in contemporary architecture might reshape the physical forms through the impact of transformative technologies on architectural design and their potential to revolutionize the built environment. This research aims to open new prospects for improving design efficiency between clients, designers, and society at large and provide insights into the transformative power of technology in shaping the future of architectural design. Advanced 3D modelling and simulation tools have

revolutionized the design process, allowing architects to create virtual representations of their ideas and explore them in a highly realistic manner.

### Radical pedagogies and education

In the eleventh and last article, **“Eco-sensitive Cyberatmospheres: Ecocentric transformations of domestic spaces”** this work aims to open a pedagogical debate on the current approach to technology in domestic spaces. As currently the use of technology is seen as a way to simplify human actions, rather than as a possibility for extending our sensory connection to the surrounding environment. On the other hand, it is also used experimentally, where, through testing the "TouchDesigner" software, the technological approach in domestic spaces is rethought towards a more communicative than solution-oriented technology. The article is a shift from the anthropocentric approach of the domestic space to a sensitive ecocentrism, where the human subject is changed by the communicative environment (understood as any non-human agent, being climatic, animal, plant, etc.). In this way, a visual exchange of information is established through technology, representing behaviors or needs

## REFERENCES

Baudelaire, Charles. *Las flores del mal*. Madrid: Alianza Editorial; 1991.

Colomina, Beatriz. Learning from Global Tools. In BORGONUOVO Valerio, Silvia FRANCESCHINI. *Global Tools 1973-1975. When education coincides with life*. Roma: Nero, 2018.

Jarauta, Francisco. *Arquitectura Radical*. Las Palmas de Gran Canaria: La Imprenta editorial; 2002.

Luengo Angulo, Miguel. *La Arquitectura Radical. Cinco puntos para una redescrición teórica*. Buenos Aires: Diseño; 2020.

VV.AA. Haus Rucker Co. Atem Zonem. Lentos Kunstmuseum Linz; 2023.

## NOTES

<sup>1</sup> Zamp Kelp. Haus Rucker Co. Lentos Kunstmuseum Linz; 2023.

<sup>2</sup> Jarauta, Francisco. *Arquitectura Radical*. Las Palmas de Gran Canaria: La Imprenta editorial; 2002.



# Radical Future (simple, continuous, perfect or perfect continuous)

A conversation between  
the Editorial Committee members

**Alvado Bañón, Joaquín<sup>1</sup>; Bovati, Marco<sup>2</sup>; Devereux, Mike<sup>3</sup>; Luengo Angulo, Miguel<sup>4</sup>; Moro, Anna<sup>5</sup>; Nobile, Maria Luna<sup>6</sup>; Stevens, Sarah<sup>7</sup>**

<sup>1</sup> Alicante University, Spain.  
joaquin.alvado@ua.es

<sup>2</sup> Politecnico di Milano, Italy.  
marco.bovati@polimi.it

<sup>3</sup> UWE Bristol, UK.  
mike.devereux@uwe.ac.uk

<sup>4</sup> Universidad Europea de Madrid, Spain.  
miguel.luengo@universidadeuropea.es

<sup>5</sup> Politecnico di Milano, Italy.  
anna.moro@polimi.it

<sup>6</sup> Umeå School of Architecture, Umeå University, Sweden.  
maria.nobile@umu.se

<sup>7</sup> School of Architecture, Technology and Engineering, University of Brighton, UK.  
s.stevens2@brighton.ac.uk

Citation: Alvado Bañón, J.; Bovati, M.; Devereux, M.; Luengo Angulo, M.; Moro, A.; Nobile, M.L.; Stevens, S. (2024). "Radical Future", UOU scientific journal #08, 22-25.

ISSN: 2697-xxxx. <https://doi.org/10.14198/UOU.2024.8.03>  
This document is under a Creative Commons Attribution 4.0 International license (CC BY 4.0)

Invited Editorial 

**MLA** - If Radical Architecture was, according to Maigayrou, a "current of research less concerned with the practice of the architectural profession than with reflecting on the bases, the foundations of architecture" (Jarauta, 2002) then maybe we should reflect on the fundamental nature of our duty, thus displacing the understanding of the craft from the architect's routine as a builder, towards an expanded reflection on the world and the architect's competence to interpret it and act in it.

**MLN** - One of the arguments of the Radical Movement has been to shift the way of looking at the role of the architect as an individual. If we look back at the roots of Radical Architecture, we realise that is made by collectives and is made for the collective. What are the qualities that defines an architectural project as "Radical"?

**MLA** - Radical projects manifest this confusion in practices that are rarely "constructive" but transgressive, critical, and most importantly: committed. All of this is intended to confront the world they've received by making its paradoxes visible and revealing the absurdity of a discipline that continues to insist on defining itself by formal and stylistic aspects to deviate towards a factual, operational architecture that acts on the real... even if it does not build anything (especially not building anything). What do you think?

**MD** - I think architecture must be about 'challenging' if it is to answer Miguel's point about 'displacing' the craft from the reflection in architecture. But such a challenge needs to be more than simply questioning, it needs to be propositional. It needs the architect to take a position and propose an alternative to the world s/he is observing and feels some dissatisfaction with.

**JAB** - When Prigogine (PRIGOGINE, ILYA. "El nacimiento del tiempo", 1998) describes Schödinger's concept, developed in "What is Life?" about the biological order, he said that there must be something in the mechanism of life that prevented life from decaying. Architecture is about the mechanism of life, there must be some irreversible mechanism about acting on the real. It is radical, it is irreversible, and it is not about buildings. As Prigogine describes later, in the chapter 'The creative role of time', Dynamic systems are never stable. It is proven in their theories that irreversible phenomena lead to new structures because of their irreversibility. This is related to the foundations of architecture, to the roots. We project in a dynamic system as a city.

In this radical time, the references with which architects work are references for the future. Validation occurs in the capacity of absorption and reaction with the capacities and references for the future. The practices are critical, transgressive and committed. The Imagined city affects the object, conditioning its existence. 'Radical City' adapts in its condition as a new reality and adapts and enables the possibility of the object of contemporary response to a future proposal. The result is quantifiable and evaluable by accepting and proposing the irreversibility of the actions, their collapse and their new implementation. The radical research is developed on assumptions where the terms acquire new meanings. Risk acts as a production method.

In a radical proposal, measurement precedes action on the hypothesis of the real drawing. The verification is based on the measurements of the working hypotheses that presuppose valuable actions.

The condition of the future and risk places us in front of new meanings to which the architect must respond directly: Virtual place: hyperlink of processes and situations capable of absorbing the future. Point within the virtual map that establishes new synergies with other objects, regardless of the physical relationship of proximity; Virtual matter: physical medium where actions are fixed, and others are reproduced. Urban void as an object of thought; Virtual structure: ability of the object to sustain itself and adapt to the imagined city. Physics applied to the environment; Virtual construction: Material measurement processes of the action and its transformation. Process logic.

The map of the real city and the map of the physical city complement each other in their double measurement, real and virtual. The radical architect not only acts on the phenomena of the city but measures them and projects them into the future. The veracity of the process is carried out on the investigation and the series of hypotheses. The Radical City is understood as an architectural object built on the void and is measured and quantified on its double real and virtual capacity for construction and durability.

**MLN** -Your reflection on the role of the radical architect focus on the role of the individual, is that still a central role? Do we still consider the architect as a "super-hero"?

**MLA** - I'd say definitely not. Radical architects permeate and camouflage collectively as writers, politicians, journalists... etc. It's a social role with social responsibility that goes far beyond our super heroic powers/total impotence.

**MLN** -An important aspect of Radical Architecture lies in the plurality of its authors and its audience. Architecture is seen as a practice to be experienced, performed, enjoyed, lived. It is mainly the result of a plurality of actions in the space performed by multiple bodies. Cities are designed for a collective body; the analogue city evolves into a non-stop city; architecture is seen as an inter-scalar object that relates to the body/ies and expands in the city infrastructure moving across boundaries, cultures and disciplines.

In the contemporary city we look at multiple dimensions, and what this implies.

Openness has been understood as the only answer to today's challenges.

There is a need – both in academia and in practice - to go back to the roots, to provide spaces for debate, to be open to plurality, to design and adapt our cities to the need of a contemporary and future society where the space is open to embrace plurality going beyond gender, nationality, race.

**MD** - I agree with Maria Luna on this point of plurality. I feel strongly that architecture is a social enterprise. After all, there is a reason why architects need the permission of 'society' before they can see their ideas built. But adherence to a societal norm at any time in order to be well received (and thereby built) is the antithesis of 'radical'. Radical requires courage to be different, to stand out and to proclaim a cause. Radical architecture then responds to that cause or manifesto. So, as a social enterprise, it is right that architecture presents new ideas to society, makes society think about where it is and where it is going. Architecture therefore needs to be political; it needs to show a new future. And, to do that it needs to be experimental and communicative. These are, at least, two essentials of radical architecture.

The radical architects of the 60s, 70s and 80s had the courage to do this. Architecture needs to do so today. It must radically, not just tamely, challenge mass consumerism, the use of technology and contemporary construction methods, and in doing so present playful but thought-provoking alternative points of view. Points of view that, as Joaquin says, are not just about buildings.

I'd like to see the University of Universities 'collective' convert a (virtual) warehouse into an architecture school by day and a nightclub for the evening in the way of Gruppo 9999. We need to create the space for students and architects to express themselves as an international radical collective voice, bringing fun and radically creative responses to today's very real societal problems.

**SS** -Mike, I agree. I feel architecture is always political. Architectural proposals always begin as fictions, in such they are all proposals for alternative futures we might inhabit. Our designs propose a vision of the future and in so doing they will always make a political statement, whether that be one of conforming or otherwise. We can never resign from this responsibility. Radical architecture opens up this opportunity, sees it for what it is and uses it to offer a view of alternative futures, painting visions of potential alternative realities we could choose to inhabit. One of my favorite quotes is from David Graeber, "The ultimate hidden truth of the world is that it is something that we make and we could just as easily make it differently". Architecture realizes the possibility of proposed future, it brings it to life, and we can choose to use that chance to make a difference.

**MLA** - Architecture is always fiction, right? At least until it gets serious and we need to build stuff to allocate functional needs and plural demands.

**MB** - The 'radical' perspective questions the role of architects: what is their place in the world? But why is this way of understanding architecture so questioning? In my opinion because, apparently, radical architecture is the furthest thing from the idea of a professional architect, harmoniously embedded in the economic and real estate mechanisms of production and reproduction of built space. For the architect, or architects in the collective

perspective, radical is 100 per cent intellectual, does not build and is not interested in the constructability of his projects. In some cases, s/he even goes so far as to deny the very idea of a project as a possible future, as anticipation, to replace it with the idea of a contingent and temporary event, however transitory. In other cases (Archigram 9 "Architecture Without Architecture"), the radicalisation even leads to the denial of architecture itself. What, then, is its real possibility to positively (or at least to condition) the human habitat? The paradox, I think, lies precisely in this possibility of indirectly but radically affecting our idea of inhabited space and its characteristics. I believe this possibility exists if we reformulate the relationship between the two terms in the play - Architecture and Radical - by overcoming their apparent separations. Utopia, radicalisation, the questioning of the seemingly acquired and established, the push towards the future, and the anticipatory vision, in fact, are the fundamental nourishment of the project (other than rejection!); they are the basic perspective of doing architecture. There is no project if there is not something to be solved that does not work in our cities, so there is no project if there is no critical thinking about the contemporary. Again, there is no project without a vision of a better future and the tension to achieve it (Maldonado, "La Speranza Progettuale"). The project-even the radical, perhaps unrealisable project-always expresses a propensity for change (projectum: to throw forward) that is based on a critical attitude and visionary capacity, without which there is no improvement whatsoever but only static preservation and reproduction of the status quo. Opposites touch each other. The ultimate in radicality can have profound effects on reality. However, this becomes possible if architects and communities maintain a close link with each other and an equally close link between the future vision and contingent reality.

**AM** -The reflection on the term radical in combination with architecture explored so far, is likely to be the key to observing architecture, both as a practice and as a discipline, within relevant positions regarding the interpretation of transformations and innovation.

Engaging with practices and the world through the lens of a radical stance, as Marco suggested, might be a key entry point. Certain theoretical readings in this sense provide support to this thesis if we can understand architecture – along with the design of cities, territories, landscapes, and ecosystems – as part of and instrumental to an evolutionary interpretation of our socio-(spatial)-technical systems. I refer here to the evolutionary perspective as proposed in Transition Studies, particularly the framework proposed by Frank Geels in his Multi-Level Perspective model, which highlights the interplay between niches, regimes, and landscapes as drivers of systemic change.

Transition studies, especially those focusing on ecological transition and its management applications, such as the work of Derk Loorbach, identify 'radical' as the defining attribute of innovations that create a decisive break with the existing status quo. Such innovations start from practices and establish a redefinition of rules that even extend to the cultural/value dimensions of the socio-technical systems in which we operate, systems where architecture – as a practice, with its rules and values – is an integral part.

The possibility of sustainable evolution does not lie in minor system updates but in a radical re-thinking of reference models, encompassing radical governance and radical policies to navigate the momentum we are experiencing. Here lies the paradox: within this perspective, for a real transition, radical architecture may be the only viable option. However, its radical nature will be measured not only by its disruptive innovation but also by its profound adherence to the transformation of the complex socio-economic and technical systems in which it operates.

**MLA** - And I'd add, definitely not to conclude the topic, that this contradictory, unofficial, playful, amateur-like, circumstantial and unorthodox Radical strategies could be deployed again to interpret some of the seemingly extreme versions of politics, culture and social status that we are perplexedly experiencing today. Thank you so much for the conversation !



# A conversation with Jarauta

Murcia, 16th October 2024

**Miguel Luengo:** Good afternoon, Paco. Thank you very much for granting me this interview. I have prepared a script with questions that I believe we can break from the start. Does that sound good to you?

**Francisco Jarauta:** Thank you. The catalog that presides our conversation can be considered a fascinating story—that of Radical Architecture—understood in its broadest sense, encompassing the territories of architecture, design, and the world of ideas that, from 1968 to 1975, proposed a new dimension of utopian world as a form of struggle and resistance to what seemed to be the only civilizational path imposed by international liberalism against any possible reflection on the future, societal forms, and ways of life. From the postulates of Situationism, a parallel path was projected to critically consider possible worlds emerging from the crises of those decades. It was about articulating the materials of a history that had already begun to take shape through the work of FRAC in Orléans and other European cultural institutions.

In your script, you ask about a possible return of the radical spirit

today, and this is an element that, from a critical and political-ethical point of view, is very important. The question might be: why? Not just concerning architecture, but

also regarding broader cultural parameters. The return to the '60s and '70s, up to around 1975, has inspired many new questions across different disciplines, including art,

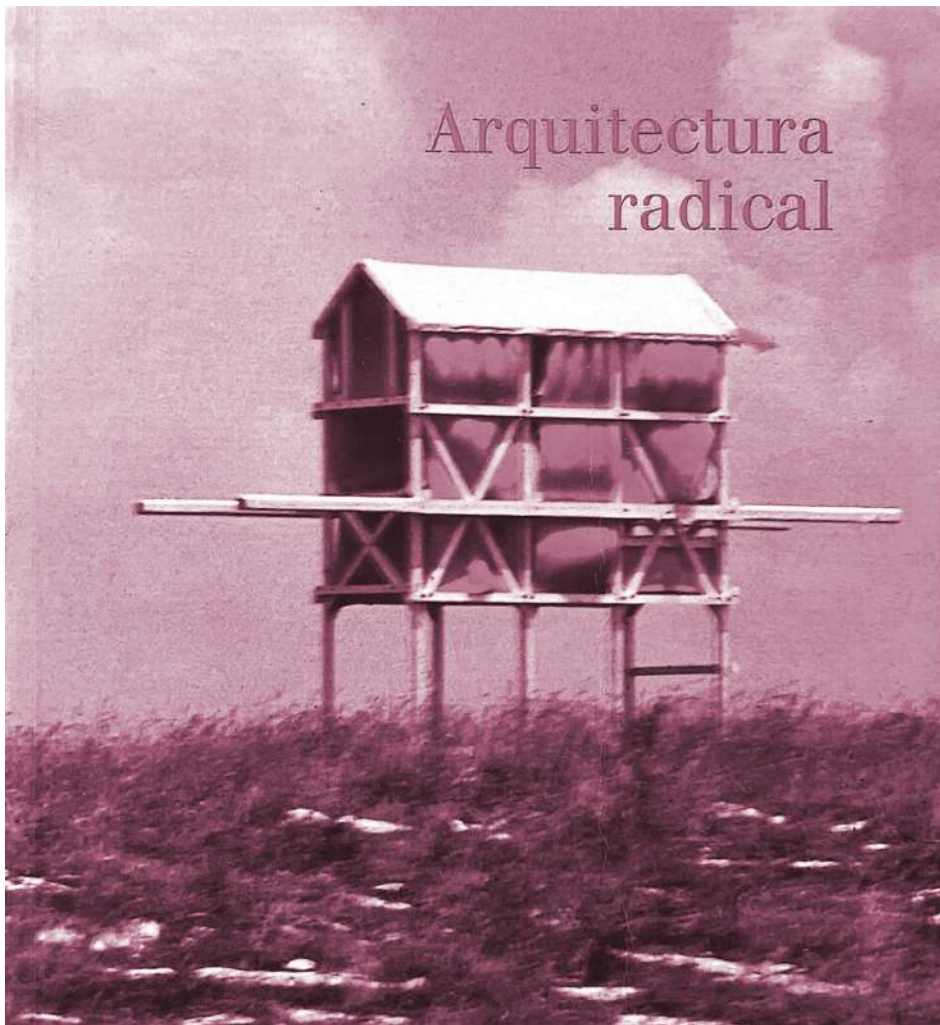

Fig.1 - Cover of *Arquitectura Radical*. Catalogue of the exhibition held at the Centro Atlántico de Arte Moderno. Las Palmas de Gran Canaria. 5th March-5th May 2002.

## Jarauta Marión, Francisco<sup>1</sup>; Luengo Angulo, Miguel<sup>2</sup>

<sup>1</sup> Catedrático de Filosofía, Universidad de Murcia, Spain.

<sup>2</sup> Universidad Europea de Madrid, Escuela de Arquitectura, Ingeniería y Diseño, Madrid, Spain.  
<https://orcid.org/0000-0002-3758-0040>  
 miguel.luengo@universidadeuropea.es

Citation: Jarauta Marión, F., Luengo Angulo, M. (2024). "A conversación with Jarauta", UOU scientific journal #08, 26-31.

ISSN: 2697-1518. <https://doi.org/10.14198/UOU.2024.8.04>

This document is under a Creative Commons Attribution 4.0 International license (CC BY 4.0)

Invited Editorial 

architecture, and design, which were previously distinct professional spaces. Now, cultural references have completely changed, but those years, from the late '60s to '75, remain decisive. The year 1968 can be considered the last barricade representing resistance to what could have been the legitimacy of an American Life model, a New American Life, that began to expand with political-economic structures and liberalism, along with a struggle tied to a very significant renewal of utopian thought, as proposed by the Situationists. Figures like Debord and, above all, the Dutch played a major role in this critique. Constant, in particular, was crucial in defining the key issues.

I was very close to Constant. I visited him in Amsterdam and frequently saw him, especially in the first community that emerged in Alba, near Turin. That's where Gallizio and all his friends gathered, but the intellectual leader was always Debord, who set the framework for their discussions.

I love that Constant comes up early in our conversation because I find his ideas captivating. I still vividly remember the day I asked him, "What question comes to your mind most often?" And he replied, "No... I'm old now... special questions... there's noise... but yes, there is one question that bothers me: why did certain ideas prove impossible?" That tension is key to his intellectual approach.

Constant addressed themes of emotional cartographies, rethinking the city, and using expressionist models from German cinema. He was very eclectic and absorbed everything he saw—a highly active sponge.

Debord presents a different image. He was a sociologist trained by the great masters whom he immediately challenged. He positioned himself within the perspective of city-related issues raised by figures like Henri Lefebvre. Around the same time, two books with the same title appeared without the authors knowing each other: Daniel Bell at Harvard wrote *Postindustrial Society*, and

Alain Touraine—whom I was very close to—wrote *La Société Post-Industrielle*. I once asked Touraine, "Didn't you know Bell?" Of course, he knew him, but they never discussed the subject, he told me. That period was crucial in understanding the intellectual context in which both Situationism and Radical Architecture emerged. It marked a turning point in deciding what kind of societies the future would bring.

At that time, Communist parties held significant social power. The intelligentsia was predominantly leftist, and very few thinkers dared to present themselves as conservatives. One exception was Raymond Aron in France. For Touraine, Aron was an indisputable master. However, there was a moment when being on the right was simply unacceptable because the battle was framed as an "aut-aut"—either-or—choice.

Debord came from a different legend. He was an intellectually respected professional, with a strong active radicalism. His suicide only added to the myth surrounding him. Some Galician colleagues once asked me if we could organize an exhibition about Debord, but I refused. It would have been too monographic, risking idealizing his case. Instead, it had to be framed within the broader context of European Situationism, openly incorporating friends from Radical Architecture circles.

Branzi, on the other hand, is a highly cultured, refined figure embedded in Milanese society during the '60s and '70s. He belonged to a bourgeois class that constructed its own narrative. They were liberal and great innovators, thinking about a new avant-garde. An extraordinary leader in that movement was Maldonado, who had enemies everywhere but was the only one invited by Zurich's ETH Polytechnic. He also went to Stuttgart and played a significant role in reopening the Ulm School founded by Max Bill. Given the proximity to Germany's automotive industry, leaders in industrial design were in high demand, and

even today, ETH Zurich has a space dedicated to Max Bill.

Branzi, more Milanese in his outlook, worked with the industry. Many iconic furniture brands of that era were born with great success. This is how the so-called Seminario di L'École emerged—an exploration of bourgeois Milanese interiors from the 1970s, featuring lamps, chairs, and armchairs.

**ML:** However, in my interview with Branzi, he emphasized the construction of identity and the severity of someone who has chosen to postulate that architecture cannot serve power and should not be dictated by it—a common practice. He cited Tafuri. Branzi also criticized Natalini a lot at the time.

**FJ:** I'm very glad you mentioned that. I've been to his studio... Natalini was somewhat Calvinist, whereas Branzi was more worldly, embodying the freedom of bourgeois thought.

**ML:** Or the freedom that comes from deciding not to build, while Natalini was criticized for drawing the Continuous Monument and later constructing postmodern buildings.

**FJ:** Yes, those buildings were indeed a tremendous contradiction in terminis, but also an anti-coherence. Branzi behaves as an intellectual, one of the great theorists of design and architecture, moving from the Roman school to the Venetian school. Ultimately, Tafuri became the great guru of a methodology applied to history, pointing to a new complexity.

**ML:** Natalini considered Superstudio a Situationist group, but beyond formal connections, I'm not entirely convinced. Could you develop this hypothesis about Radical Architecture's connection to Situationism?

**FJ:** I believe there is an appropriation of the concept by the radicals, who anchor it more in the territory outlined by the Situationists. The Situationists were more concerned with ways of life and the emergence of new social structures. That was their primary



focus. However, aspects directly tied to architecture as a practice did not appear in their thinking. They recognized that architecture played a prominent role in shaping ways of life, and that was a step added to Radical Architecture. Many of them, despite lacking formal intellectual training, had a remarkable cultural background. For example, Gianni Pettena and others were great travelers. They often exchanged ideas and places, but I believe the discovery of architecture as a problem specifically belonged to Radical Architecture.

**ML:** Because Constant, within Situationism, proposed fully architectural projects, don't you think?

**FJ:** Let's say they were architectural in their consequences, but as projects, they remained experimental. He often said he loved photography as a compositional element. His cartographies ended up being drawings designed to situate specific cases, but they lacked the strength to make him a necessary interlocutor for architects of the 1970s.

**ML:** In your text, you mention Archigram. Perhaps they can be interpreted not so much from those critical premises deeply embedded in the social and cultural, but rather as straddling positivism, linked to how Viollet-le-Duc or Laugier used technology in Archigram's projects like the mythical Plug-In City, but also in more ironic ones like Walking City. However, you do consider them purely radical because they incorporate that social and cultural component.

**FJ:** They always did. Even as a school, they maintained theses that entirely questioned and problematized existing models of legitimacy. The British model is very particular—they have a unique respect for technological elements. Their early studies were groundbreaking. It didn't matter to them whether they were designing airports or supermarkets. Rogers is the most convincing of all of them... but of course, he doesn't belong to what we would call the radicals, not at all. There is a matrix in British

architecture that later directly influences Archigram and spaces like Peter Cook's building in Graz. For Peter, constructing that model, that city diagram, is possibly the most brilliant example of Radical Architecture. The movement itself, however, is made in Italy. Celant coined the term, and that became the standard. Celant loved coining names. Right now, there's a major exhibition in Paris on Arte Povera that follows this line.

**ML:** Like the Smithsons' primitive hut?

**FJ:** Exactly. The Smithsons represent the dream everyone dreamed of in Whitechapel.

**ML:** I was thinking about models of legitimacy and one of the questions from the script that we're skipping over (laughs). Branzi himself—and almost everyone—says that Radical Architecture is not a homogeneous movement, much less a style, but rather the sharing of a state of mind. In this critique of models of legitimacy, is it very different to be a radical in England compared to Italy or Austria, and is that why their productions are so different?

**FJ:** Imagine Vienna in this context. All the different schools they labeled as radical present very few common parameters. It's a mindset, an intellectual device to think about things. Vienna is fascinating in this respect because it developed in a very conservative architectural environment, like the Ring, with a modernism that had no interest. I see it repeatedly, removing the elements that are essentially museum pieces. When Hans Hollein proposed that glass building in front of the Stephen's Kirche, it was a form of admirable resistance.

**ML:** Let's target that shared state of mind with Coop Himmelblau, Haus-Rucker-Co, etc. In contrast to projects labeled as radical, like the more conceptual Continuous Monument or No-Stop City, the Austrians actually build things. They tend to be inflatable, but they have that technological and constructive component. What's your take on that?

**FJ:** They are highly technological. They introduce, firsthand, a technological recovery that other architectures did not produce, and they do it effectively.

**ML:** Why effectively?

**FJ:** Effectively, because there is no debt to the rationalism of the modern movement, and there is no primacy of function. And yet, they create a machine. The idea of the Machine dates back to the 1920s and spread across all fields. There was even a moment of internal debate at the Bauhaus: whether to emphasize more on the Machine or focus on what we might call Classical form. They chose the Classical form. Look at the apartments Gropius built for professors—what's modern about them? They look like comfortable homes with some scenic views of the Saxon forests... though they aren't bad.

**ML:** What happens with the Austrians is that they tend to make an explicit, even aggressive, use of technology, but with a critical component, sometimes parodying the technology itself. I remember projects like Face Space by Haus-Rucker-Co, where you put on a helmet, and facial expressions are transformed into lights of different colors. It appears to be a celebration of technology, but I see it as a critique of recent mass communication media and technology itself. What's your take on Austrian irony?

**FJ:** It goes beyond irony. It reaches a paradox where what would seem logical ends up being unnecessary. However, there is a display of performative objects—very fixed and powerful—but it's not architecture meant for living.

**ML:** One could also argue that it's not just that it isn't architecture for living, but that it isn't architecture at all. There are many criticisms (perhaps superficial) of Radical Architecture as being superfluous or anecdotal because it transgresses classical definitions of the discipline. It's like saying, "You can lecture about this in class, but when you're done with that nonsense, let's talk about cubic meters of concrete—

that's where architecture really is." What do you think of the concept of non-architecture, for example, in Gianni Pettena's Anarchitect?

**FJ:** The Anarchitect... there was a debate that took place in the 1970s and 1980s at the Politecnico di Milano, where the great masters gathered. Pettena is an outsider. Just look at the exhibitions held at the Triennale, even in the '80s. There, you'll find an extraordinary figure, a recognized authority for everyone—Sottsass. He traveled to India, Japan, and brought back drawings that he exhibited at the Triennale, leaving all the great architecture masters in the dust. There are other architectures and magical moments, like when he invented the Valentina typewriter. All the great writing devices—Underwood machines, those war machines—were distributed worldwide and even appeared in American noir films. Even a judicial protocol had to be done with one of those machines. Yet Pettena ventured into another world, but he is not very convincing. The Anarchitect is more about developing landscapes, perhaps ruins. He even wrote a text on ruins for the Valencia Biennial. Do you have the catalog from that Biennial? There's an extraordinary final section in it. Pettena created a piece almost 30 meters high. Yona Friedman also participated with his concept of light structures. He arrived with nothing—he hadn't sent anything in advance. When we reached the shipyards in Valencia, he took a walk around and saw a construction site. He asked, "Could I borrow a wheelbarrow?" He grabbed some concrete blocks, about 20 of them, and created the base. Then, he went to a glass vendor and bought a 2x2 glass panel, placed it on top of the blocks, and said, "Let's build some floors." We bought 200 rolls of toilet paper, removed all the paper (what a job!), and used the cardboard rolls as the building's columns. Then came another 2x2 glass panel (which can hold perfectly), followed by another 200 rolls of toilet paper. He used only white and blue colors. He drew a floor plan, then another, building four vertical structures. And... this is a legacy of those ideas, challenging

the concept of who would live there!

**ML:** I was thinking about Sottsass's role as a mentor, both for Pettena and others. I believe they owe a lot to Sottsass, don't they?

**FJ:** Incomparable! Sottsass is an outstanding figure recognized by everyone. He is anti-system, but in a classic way. His cosmopolitan outlook allowed him to select elements that fascinated him without owing intellectual debts to anyone. He traveled extensively, always bringing surprises. The invention of the Valentina typewriter by Sottsass is an interesting case. At that time, Olivetti was a crucial company in Italy, driving innovation in various industries. Even Le Corbusier designed one of their plants. Olivetti was often accused of being too Catholic, which personally bothered me. However, they were an advanced industrial bourgeoisie that understood the importance of innovation. Sottsass received a commission and began tailoring his work to the company's needs.

In individual workspaces, people wouldn't use large German Underwood typewriters. Instead, Sottsass made the Valentina out of plastic. I vividly remember seeing a giant Valentina exhibited on the ground floor of the Beaubourg in Paris during a major Sottsass retrospective. People worshipped it. There was even an American project along similar lines, but Sottsass got there first. Everyone was already working on the Valentina format. He also collaborated with a playful industrial designer. However, Sottsass remains untouchable.

**ML:** But while Sottsass is untouchable, he also mentors theoretical "products" like the Safari divan, which, according to furniture history, was so fabulous that one almost didn't deserve it. It wasn't just a sofa; it forced you to elevate yourself to justify owning it. What do you think about this almost baroque, or at least non-classical, phase where boundaries were pushed?

**FJ:** Yes, there was a very active neo-baroque sensitivity during that time. I even organized a seminar

on neo-baroque at the Círculo de Bellas Artes in Madrid, with prominent figures like Calabrese, Lyotard, and others in attendance. They all shared ideas through open discussions.

**ML:** That trajectory aligns with Andrea Branzi's Trojan Horse theory—how these products infiltrated the calm, comfortable world of design to destroy it from within. This reminds me of a question I've wanted to ask you, Paco: Is the radical mental state still present today?

**FJ:** I don't think so. Sociologically, we see neo-functionalism, which lacks the rigor of 1970s and 1980s design. Back then, there was a tour de force advocating for significant formal innovation. Dorfles wrote a lot about this. Today, there's a sweeping away of the unnecessary and an imposed canon. Danish companies resist this trend, unlike the Dutch, who have shifted toward office furniture and are now the strongest in that field. Our friend Santiago Miranda, the creator of the TamTam lamp, presented a bureau design line to one of the strongest Dutch companies, raising many questions. That's when office spaces became compartmentalized, with open spaces fostering communication in work culture.

**ML:** If communication produces the social, and if we accept that we now live in a hyper-connected and hyper-communicated time, wouldn't that make this a radical era?

**FJ:** In that sense, yes, we are advancing. Large corporations already have extensive reports on how societies will be in 2050. They all agree that the most active vector will be Communication, Communication, and more Communication. Today, investments in communication are growing exponentially, but their direction remains uncertain. They drive research processes not directly linked to communication itself. Historically, the most significant event is the grand alliance between technologies and financial capital. If you want a snapshot of the 22nd century, take a walk around Basel. Along the Rhine, you'll find all the





Fig.2 - Picture of the interview by Beatriz Ballesteros Sánchez.

world's major pharmaceutical buildings, illuminated at night in a spectral way.

**ML:** Basel, if I recall correctly, hosted Coop Himmelblau's Restless Spheres as a critique of dormant cities, similar to Archigram's Instant City. I'm particularly interested in how communication produces the social. It's not just that people realized this—it's that the scale and communication channels have changed, with mobile phones, social networks... Do you think this impacts that "production of the social"?

**FJ:** We're still at an initial stage. Imagine communication content increasing 12,000 to 15,000 times beyond what we have now. We're small experimenters in the early phases of this domination by communication flows. The issue isn't just fake news; everything will become fake news—simulations. I discussed Baudrillard's concept of the simulacrum during a seminar in Paris. It's incredibly powerful. When I talk about the simulacrum, I mean something we know isn't real but fundamentally occupies the space of the real.

**ML:** So, within the context of the spectacle society?

**FJ:** Exactly. Debord introduced this from a macro perspective. We're heading in that direction. Earlier, Baudelaire was fascinated by the aura of merchandise. Walking along the boulevard wasn't for the enjoyment of the voyeur but for the commercial undercurrent. Baudelaire argued that everything becomes merchandise, and he ended up exiled in Brussels, stating, "Everything transforms into melancholy, but initially, it's all merchandise."

**ML:** I was thinking about how Radical Architecture, even tentatively, places significant importance on communication. Their experiments weren't private exercises for a select few. If we think of Le Corbusier—who was a great communicator—perhaps communication, or even an overemphasis on communication, is essential to the radicals.

**FJ:** Indeed, but the parameters have changed qualitatively. Today's communicative input is vastly superior. The radicals, from a perspective of struggle (because they knew they were fighting for something), sought visibility for their work. Virilio did this well. He said the most important anthropological element was domesticating vitesse—speed. He was extremely radical and always on edge. After Hiroshima, he argued that anything could happen, even discussing biological weapons. There's radicalism in their work, but communication has fundamentally shifted. It's now a machine. We need to reclaim the concept of Machina.

**ML:** Do you think the concept of the machine is worth reclaiming, even in small-scale guerrilla-style operations? Can it be instrumentalized?

**FJ:** That's a great question for Sennett. He believes small communities must organize around struggle, not survival. You fight with your ideas, your projects, your experiences. Experience is a formidable weapon. We need to educate—to position people within that horizon of creative experience. You destabilize the house and open yourself to another space. And that space is time. The classics said, *Tempus templum*: time is the house.

**ML:** And what's your opinion on Koolhaas as a radical or post-radical?

**FJ:** I admire Rem. He's a powerful architect and thinker, though some of his projects are quite controversial.

**ML:** As an architect who builds buildings or more in the realm of thought?

**FJ:** I think he has made necessary reflections. Delirious New York is fantastic and addresses many of these ideas. The British Pop Art movement of the '50s and '60s taught us many things. Richard Hamilton put certain issues on ice and then refocused attention on them. He's an impressive artist who fascinated all of them. Koolhaas comes from a different tradition but

is also very radical. He has adopted the laws of advanced capitalism. His partners aren't moral advisers. He's aggressive and powerful.

**ML:** But he still shares that critical ethos, right? I recall a project of his that fascinated me, which uses research as a creative premise for preserving Beijing. He traces a timeline of preservation history from the Industrial Revolution and concludes that if historical preservation continues at its current rate, we'll eventually conserve buildings that haven't even been built yet. From there, he proposes a preservation plan for Beijing that consists of a homogeneous grid where the central core—10%—is preserved uncritically, regardless of what's there.

**FJ:** That fits within the radical constellation—a thought process where facts impose their own rules. The Chinese TV building in Beijing evokes vehement reactions. Its formal impact is overwhelming. I didn't enter the building, but seeing it from the outside was a shock. What I like most about Koolhaas is his writing style, where his cross-sectional analyses allow you to think deeply. He has undoubtedly taught many people. His text for Mutations is remarkable.

**ML:** I don't want to end without asking whether Radical Architecture should still be studied—not as a historical movement like Gothic architecture but as something that remains present or should be present. Or should it be archived?

**FJ:** Definitely not archived. It remains present in many forms. However, there aren't always appropriate imitations. I think there is a mentality, an intellectual stance, that directly questions architectural forms and problems. And I believe we can continue questioning it today. It's increasingly present in seminars and exhibitions, like the one on Gianni Piretti at FRAC in Orléans.

**ML:** Paco, infinite and radical thanks. I'm deeply grateful.

**FJ:** Thank you. Let's stay in touch.

# **RADICAL DEFINITIONS**



# The Italians do it Better!

A contemporary interpretation of the radical movement

architettura radicale  
global tools  
Koolhaas  
postmoderno  
**radical architectural**  
**global tools**  
**Koolhaas**  
**post-modernism**

L'architettura italiana è sempre stata caratterizzata dalla 'necessità di una teoria'(Gregotti, 1983) e profondamente segnata dalla tradizione culturale del Bel Paese. Questa specificità ha, da sempre, generato una sostanziale divergenza di significato tra i movimenti nati all'estero e la loro 'traduzione' in Italia. Così come l'architettura moderna italiana, a differenza di quella d'Oltralpe, ha rifiutato in sostanza il concetto di "tabula rasa", anche l'architettura radicale di gruppi come Superstudio, Archizoom e, in generale, i Global Tools si distingue profondamente da esperienze analoghe e contemporanee in Europa, come quelle degli Archigram o dei Metabolisti.

L'articolo prende avvio da una rilettura critica dei movimenti radicali italiani, cercando di ricostruirne la specificità e l'apporto teorico. Prosegue poi con un'analisi delle ragioni per cui assistiamo oggi a un revival di quella stagione e di come tali movimenti furono accolti dalla critica contemporanea. Nemo propheta in patria verrebbe da dire: gli architetti radicali italiani, infatti, furono spesso considerati dalla critica italiana, nella migliore delle ipotesi, dei provocatori o, nella peggiore, figure marginali che, non volendo impegnarsi in un cambiamento reale, si rifugiavano nell'utopia.

Tra i pochi che compresero l'importanza e il potenziale dell'architettura radicale vi è sicuramente Rem Koolhaas. Attraverso un'analisi critica delle numerose connessioni tra la ricerca di Archizoom e Superstudio e l'attività teorica e progettuale dell'architetto olandese, il paper cerca di evidenziare il valore scientifico di quell'esperienza, la sua attualità e la possibilità che essa possa rappresentare l'inizio di una nuova e più efficace stagione di risposta alla crisi.

Italian architecture has long been characterized by what Vittorio Gregotti termed the "need for theory" (Gregotti, 1983), deeply shaped by the country's rich cultural tradition. This unique context has consistently led to a significant divergence in how architectural movements originating abroad are interpreted or "translated" within Italy. For instance, while modern architecture in Italy largely rejected the concept of tabula rasa - a notion embraced by many transalpine countries - Italy's radical architecture, exemplified by groups like Superstudio, Archizoom, and the Global Tools, also stands in stark contrast to similar contemporary movements in Europe, such as Archigram or the Metabolists.

This article begins with a critical reevaluation of the Italian radical movements, seeking to reconstruct their distinctiveness and theoretical contributions. It then delves into the reasons behind the current resurgence of interest in these movements and examines how they were received by contemporary critics. One could say, "nemo propheta in patria" - indeed, Italian radical architects were often viewed by the Italian critics, at best, as provocateurs or, at worst, as marginal figures who, instead of engaging in tangible change, sought refuge in utopian visions.

One of the few figures to grasp the significance and potential of radical architecture was Rem Koolhaas. Through a critical analysis of the numerous connections between the research of Archizoom, Superstudio, and Koolhaas's theoretical and design work, this paper aims to underscore the scientific relevance of the radical architectural experience, its contemporary relevance, and its potential to inspire a new and more effective response to today's crises.

**Scala, Paola<sup>1</sup>**

<sup>1</sup> Università di Napoli Federico II, DiARC Department of Architecture, Naples, Italy.  
<https://orcid.org/0000-0002-1967-3833>  
[paola.scala@unina.it](mailto:paola.scala@unina.it)

Citation: Scala, P. (2024). "The Italians do it better", UOU scientific journal #08, 34-41.

ISSN: 2697-1518. <https://doi.org/10.14198/UOU.2024.8.05>  
This document is under a Creative Commons Attribution 4.0 International license (CC BY 4.0)

Article Received: 15/09/2024  
Received in revised form: 01/10/2024  
Accepted: 10/11/2024





## RADICAL ARCHITECTURE AND PROJECT OF CRISES

*What does it mean for young architects and scholars to look so closely today to some short-lived experiments by young designers forty years ago? Is this a kind of nostalgia for an early phase of radicality? Or even nostalgia for an earlier phase of the global, when the very idea of resources and tools was redefined in the face of new technologies and a new awareness of planetary ecology? Are we in another phase of retooling the disciplines of design, a kind of echo of a too quickly forgotten historical moment? Is this book about the past or the future?* (Colomina 2020,4)

Beatriz Colomina opens (Colomina 2020,4) the 2018 volume on Global Tools (Borgonovo, Franceschini 2018) with these words. Indeed, it was towards the end of the 2010s that Italy began to revisit the experience of Italian radical architecture in a more proactive light, moving beyond the previously dominant and reductive view that regarded the radical architect merely as someone who evaded problems and explored the world of the fantastic and utopia (La Pietra 1983, 15). In recent years, however, we have witnessed a critical reassessment of the scientific significance of these movements. This reevaluation began with the exhibition "Towards a new Athens Charter" by Studio Branzi at the 2010 Biennale, directed by Kazuyo Sejima, and continued through numerous publications dedicated to the work of Superstudio, Archizoom, and UFO, culminating in recent exhibitions that have spotlighted previously overlooked figures, such as Riccardo Dalisi.

Why, after more than fifty years, are Italian critics and scholars revisiting an experience that was long considered minor and often relegated to the realm of design rather than architecture? One possible explanation is that the new millennium began under the shadow of crisis. The collapse of the Twin Towers in 2001 shattered the

illusion of a stable geopolitical order centred around the dominance of the Western world, which viewed itself as an "exporter" of culture, progress, and - unfortunately - democracy. Additionally, the economic crisis sparked by the 2006 real estate bubble, coupled with the increasingly urgent environmental crisis, has exposed the vulnerabilities of modernity - issues that had already been extensively critiqued from a philosophical standpoint by figures such as Lyotard, Foucault, Guattari, and postmodern thinkers in general, starting in the latter half of the 20th century.

As Renato De Fusco wrote, postmodernism was something capable of creating an 'ugly architecture' but also of establishing a convincing 'condition of thought' (De Fusco 2012, 459). In the realm of architecture, postmodernism is often associated with designs that, from a formal perspective - and sometimes with rather questionable results - attempt to revive traditional forms and motifs, frequently through the lens of irony that alludes to a sense of continuity as a counterpoint to the modernist principle of the tabula rasa. However, the more intellectually-driven architectural movements that sought to critique modernity from a conceptual standpoint - particularly the work of radical architects - were often misunderstood. Critics frequently failed to recognize the critical depth of these movements, which were obscured by their provocative methods and actions.

In the 1990s, De Fusco himself liberated the postmodern "condition" from the architecture of the same name. He shifted the interpretation away from stylistic and linguistic terms, opening it up to a more inclusive, fertile logic that culminated in what he called the 'code of micrologies' (De Fusco, 1992,451). This historiographical concept, developed by the Neapolitan historian, encompassed all architectural research and movements unified by a focus on 'minor things' - a trait shared by all architectural endeavors that opposed the grand narratives of the

Modern Movement (De Fusco 1992, 451). Under this inclusive code, De Fusco grouped together architects as diverse as Rossi, Stirling, Portoghesi, Venturi, and De Carlo, as well as collectives like Archizoom and Superstudio. These figures and groups shared a common opposition to the grand universal narratives typical of modernity, favouring instead an architecture that prioritized the chronicle over history<sup>1</sup> and aimed to provide local rather than universal responses by interpreting urban contexts.

In his writings, De Fusco expressed concern that the rejection of metanarratives could cause the discipline to retreat into trivialities, becoming disconnected from the core of architectural theory and practice. He believed this had, in fact, happened within radical architecture. According to De Fusco, radical architects withdrew into the realm of design, in contrast to historicist architects, who, in his view, maintained a strong commitment to the discipline, particularly its design and drawing aspects, making these their defining mission (De Fusco 1992,452).

## REVIVAL

When De Fusco wrote his "Storia dell'Architettura contemporanea", he was still too close to the years of protest to fully appreciate the potential of the research



Fig.1 - Front page of Casabella, N. 377, May 1977. The Global TOOLS.

conducted by radical architects. A more convincing reevaluation of these positions is offered by Pier Vittorio Aureli in his book "Il Progetto dell'Autonomia" (Aureli 2016). In it, Aureli argues that there is an ideological affinity between Aldo Rossi, Giorgio Grassi, and the Florentine group Archizoom Associati (Andrea Branzi, Paolo Deganello, Massimo Morozzi, Gilberto Corretti). This affinity is expressed through a shared critical stance towards the capitalist city, which is built on the modernist paradigm of the form/function relationship. For the architects of the Tendenza, this critique justifies their research into the underlying reasons behind architectural form and the exploration of architectural archetypes. For Archizoom, it translates into a vision of a city 'without architecture' (Fig.2), one that fully aligns with the immaterial flows that pass through it.

By critically reevaluating the relationship between Archizoom Associati, Giorgio Grassi, and Aldo Rossi, Aureli restores a distinct identity to Italian radical architecture, setting it apart from international movements that are less conceptual and more inclined towards technological visions. He argues that "No-Stop City" represents a critique of the utopian urban projects proposed by neo-avant-garde groups like Archigram and the Metabolists. *Unlike these groups, Archizoom proposed a city without quality, without architecture, cold, infinitely extendable, and where every possible difference is absorbed into a system that reflects the three key spaces of the neo-capitalist city: the factory, the car park, and the supermarket* (Aureli 2016, 113-132).

For Aureli, Archizoom's "No-Stop City", much like Hilberseimer's "Vertical City", embraces the destiny of the capitalist city, pushing it to its extreme consequences. This results in an architecture without form, abstract and determined by the objectivity of production relations, yet infused with a kind of cold exaltation. Most importantly, Aureli emphasizes that Archizoom, like Hilberseimer, recognizes the *intrinsic validity of the project as*

*theory* (Biraghi 2016).

Far from being a mere prediction, a project becomes a tangible manifestation of reality, existing independently of physical realization. It is no coincidence, then, that during a new and arguably more dramatic crisis of modernity, the 2010 Architecture Biennale rediscovered the work of Andrea Branzi (Fig.3), a leading figure of the radical movement and member of the Archizoom group. The exhibition, titled "People Meet in Architecture", sought to reframe the discussion around architecture by emphasizing its social and public dimensions. This "immaterial" dimension positions architecture as a meeting place for the flow of people, goods, traffic, and, crucially, information.

## LEGACY

One of the key ideas shared by the Italian radical architects - many of whom collaborated between 1973 and 1975 in the Global Tools movement - is the rejection of architecture's purely formal aspects. Instead, they emphasized the value of the project not only for the material forms it creates, but more importantly for its potential as a critical intervention in reality. This shift in thinking is likely one reason why, starting in the early 21st century, architectural scholarship began to revisit this period of study, highlighting the "crisis projects" of groups like Archizoom and Superstudio, as well as the educational initiatives of Riccardo Dalisi in the fragile territories of Naples' outskirts, and Ugo La Pietra's urban practices in public spaces.

While Archizoom's "No-Stop City" rejects the formal aspects of architecture, envisioning a city shaped by "information," Superstudio focused on the project's ability to critically interpret reality through imagery. Their "12 Ideal Cities" project is a collection of texts (with an epilogue that underwent several revisions), accompanied by illustrations, primarily by Gian Piero Frassinelli. The work was first published in

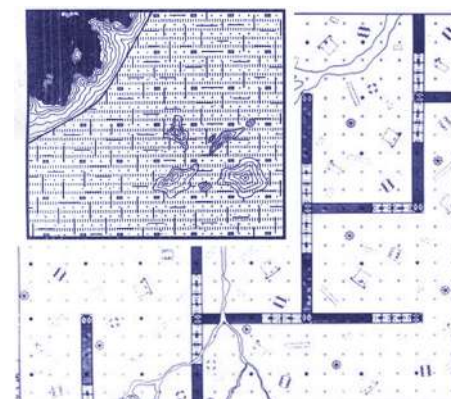

Fig.2 - NO STOP CITY [1970] Archizoom.



Fig.3 - Merchandise metropoli, Studio Branzi, Biennale di Architettura 2010.



Fig.4 - 2000-Ton City, Superstudio, 1971.

"Architectural Design" in late 1971 and later in "Casabella" in early 1972 (De Flego 2016). Each project is represented by an image that exaggerates and critiques an anthropological aspect of modern urban life.

Thus, "2000-Ton City" highlights (Fig.4) the isolation of modern man, while the "Temporal Cochlea City" addresses the alienation experienced by individuals forced to abandon their sense of individuality. "New York of Brains" portrays a society reduced solely to rational thought, while the "Spaceship City" - bearing a striking resemblance to the spacecraft in "2001: A Space Odyssey" - depicts a generation of individuals traveling through space, nourished by the spaceship itself as they await arrival in new worlds to colonize.



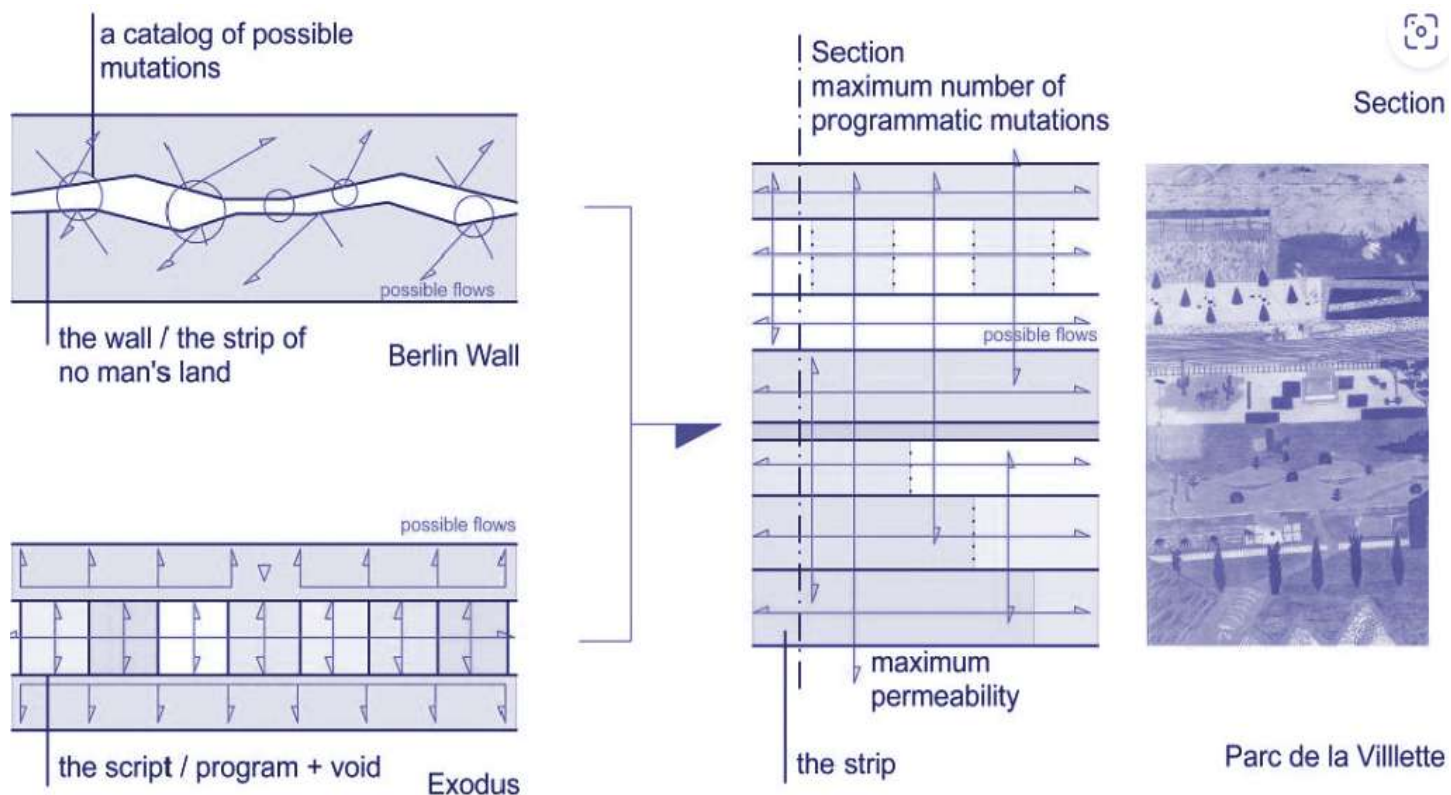

Fig.5 - Development strategy of strip in Parc de la Villette drawn by Özyay Özkan. Source <https://cansukokblog.wordpress.com/2020/04/05/social-condenser-la-villette-of-koolhaas/>.

The "City of Hemispheres" explores the theme of man imprisoned within a city that stifles individuality and creative thought, while "The Magnificent and Fabulous Barnum Jr.'s" presents a dystopian, artificial world where primal human instincts are suppressed. The "Continuous Production Ribbon City" anticipates critiques of a development model that exhausts resources and generates waste. Similarly, the "Ville Machine Habitée" represents the exacerbation of modern city life, where individuals are condemned to repeat the same paths throughout their lifetimes.

The "City of Order" appears to be a conventional urban structure but, where rebellious individuals are lobotomized and transformed into puppets. The "Tiered Cone City" serves as a metaphor for capitalist society, where individuals are locked in a struggle to reach the top of the pyramid. Meanwhile, the "City of Splendid Houses" critiques architecture focused exclusively on decorative elements, neglecting the structural reality of the modern city, which consists of basic, utilitarian cells.

Finally, the "City of the Book" -

which draws visual comparisons to Hilberseimer's architecture - presents a society where individuals choose to live by moral or practical principles. This choice determines whether they live "in the light" on the building's exteriors or "in the dark" at its core.

The significance of these 12 figures lies not in a desire to propose new urban models, but in their symbolic value and, most importantly, in the critical and provocative nature of what we could, paraphrasing Benjamin, refer to as a series of "city images".

Among those who inherited this legacy and transformed it into a critical reflection on the sense and meaning of the contemporary city is, without a doubt, Rem Koolhaas. In his "History of Post-Modernism", Charles Jencks briefly references Archizoom and Superstudio in a footnote on page 192, under the section on Generic Urbanism. He writes: «the Generic City represents more than an organized movement; it reflects a current of architects, including O.M. Ungers, Archizoom, and Superstudio, who, in the 1960s, promoted abstract urbanism based on generic forces, Platonic geometry, and systems of grids,

circles, and polyhedrons that shape urban layouts. Rem Koolhaas celebrated this vision in his projects and his essay "Generic City"» (Jencks 2014, 192).

Koolhaas describes the Generic City as «the city liberated from the captivity of centre, from the straitjacket of identity» (Koolhaas 1994, 1259). This city has no predetermined form but instead expands like a liquid in all directions, with its molecules held together by weak forces. This concept of modernity - liquid, weak, and diffuse - echoes Branzi's vision of the "No-Stop City", a city regulated solely by the flows passing through it and best represented through diagrams.

It is through this diagrammatic approach that Koolhaas illustrates what he calls Programmatic Instability (Koolhaas 1989, 197). According to this idea, the architectural project is not the result of a traditional compositional process but rather emerges from a program that generates a flexible structure, one capable of absorbing and adapting to continuous change.

The programmatic layering upon vacant terrain encourages dynamic coexistence of activities

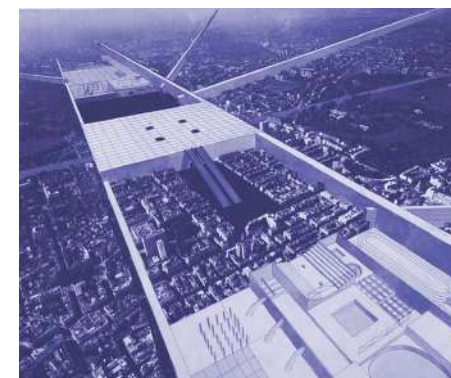

Fig.6 - Exodus, Rem Koolhaas, Madelon Vriesendorp, Elia Zenghelis, and Zoe Zenghelis, 1972.

and generates, through their interference, unprecedented events. According to this logic, the goal of a project is not to create a "flexible" space that merely accommodates all pre-planned functions, but rather an "open" space - one capable of embracing and, more importantly, activating unforeseen uses and events. Parc de la Villette was perhaps the first OMA project to translate the concept of programmatic indeterminacy into urban-scale design. In the

competition proposal, the functional program outlined in the brief is interpreted as a series of diagrams, each representing a distinct layer of the park. The result is a product of a distributional logic that is completely free from the constraints of compositional synthesis. The final "design" of the park emerges from the superimposition of these independent layers.

Perhaps the most significant and officially acknowledged debt Koolhaas owes is to Superstudio. In his short text "Field Trip. A(A) Memoir (First and Last...)", where he reflects on the atmosphere at the Architectural Association School of Architecture in London during the early 1970s - and where Koolhaas studied and where Peter Cook, among others, taught - he teases Archigram but makes a point of highlighting the influence of Italian radical architects on his theoretical development. He notes: «Superstudio, founded in 1966, is an Italian group of avant-garde architects; I was personally very

impressed by their 'continuous monument' and had organized a few lectures by Adolfo Natalini at the A(A)» (Koolhaas 2021, 73).

Figuratively, the similarities between Superstudio's projects and some of OMA's work are evident (cfr Fig.4-8 and Fig.6-7). However, the images in OMA's projects are never just simple illustrations. Even when they take the form of explicit "quotations" from other works, these images point to the "conceptual debt" Koolhaas owes to his influences

The 1972 Exodus (Fig.6) project, developed in collaboration with Madelon Vriesendorp, Elia Zenghelis, and Zoe Zenghelis, explicitly references Superstudio's Continuous Monument (Fig.7) as well as the 2000-Ton City. This project, as is widely known, was inspired by the profound impact the Berlin Wall had on a young Koolhaas during his visit to the city, a symbol of the Cold War. At the time, Koolhaas was still a student at the

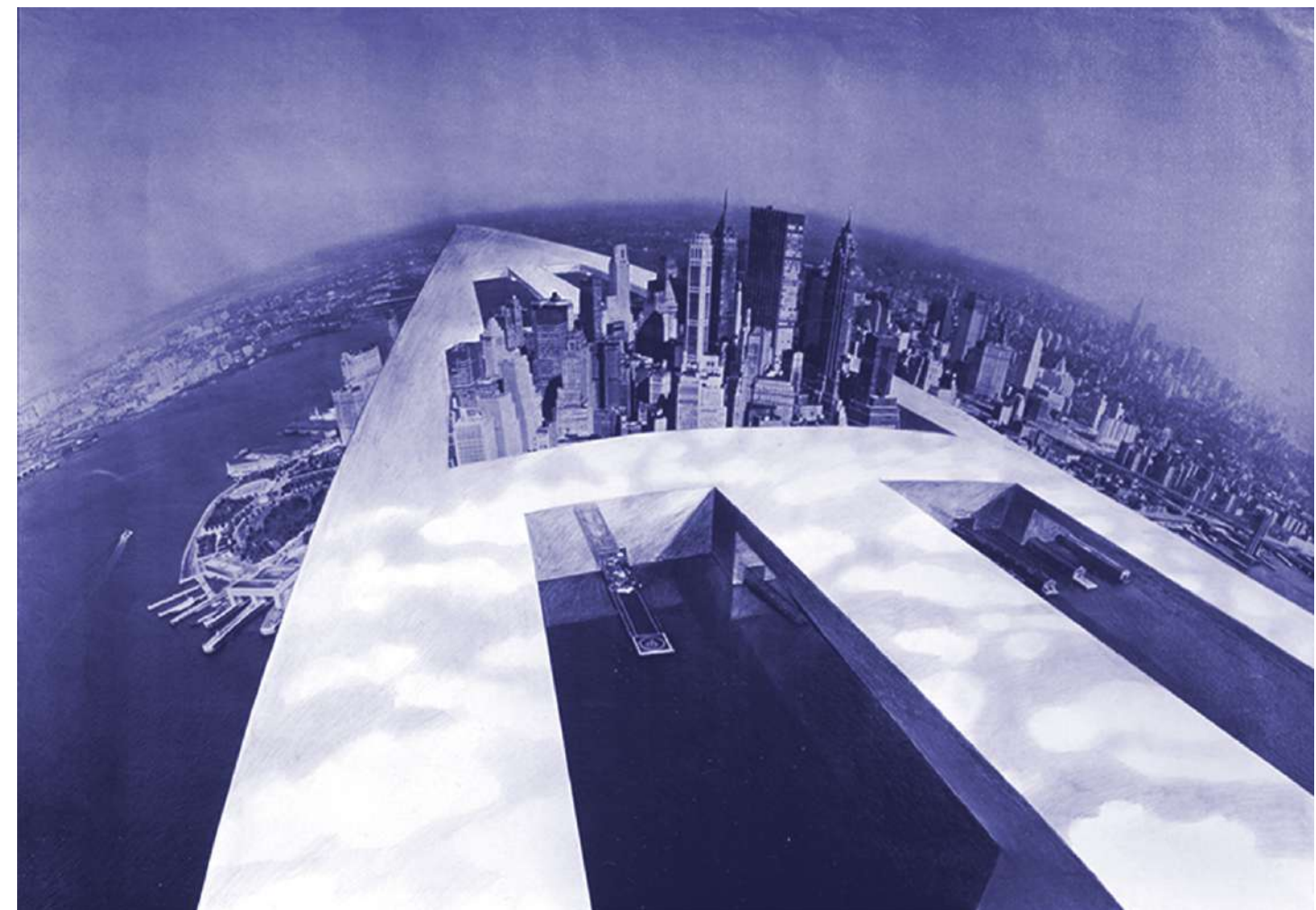

Fig.7 - Continuous Monument, Superstudio, 1969.



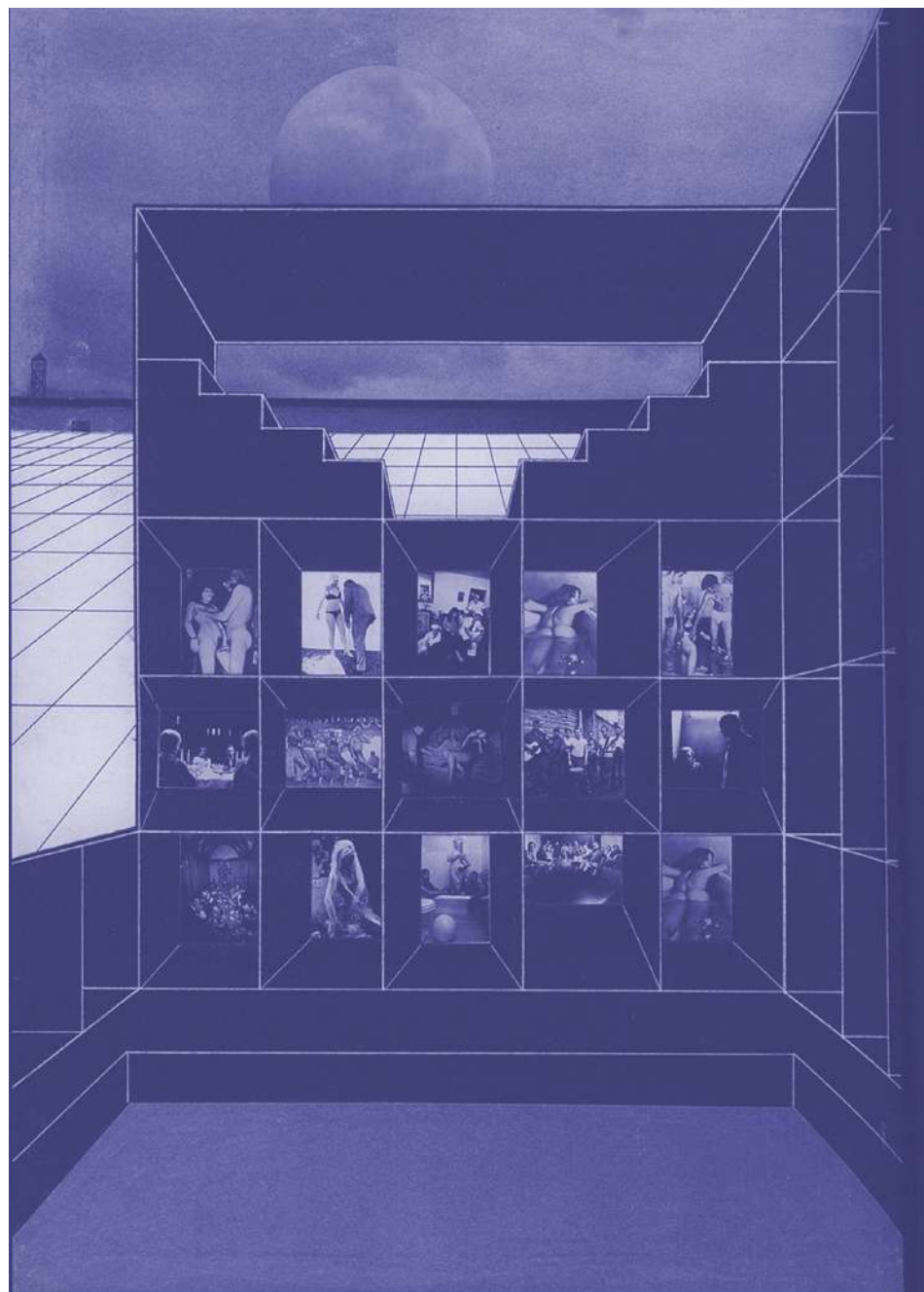

Fig.8 - Exodus, or the voluntary prisoners of architecture Rem Koolhaas, Madelon Vriesendorp, Elia Zenghelis, and Zoe Zenghelis, 1972.

AA, and his encounter with what he described as "horrific and powerful architecture" planted the seeds for themes that would later become central to his theoretical and design work. Reflecting on the experience, Koolhaas observed:

*On the level of negative revelations, the Wall made any emerging attempt to link form and meaning seem absurd, in a binding regressive relationship [...] I would never again believe in form as the main vehicle of meaning.*

Koolhaas was struck by the Wall's ability to distort the meaning of the reality in which it was embedded.

It was perhaps at this moment that the concept of architectural design as a "critical paranoid" process (Koolhaas 1978) began to take shape - a process where design does not emerge from a contextual analysis, but rather from an interpretation of reality that occurs in the architect's mind, generating a new image. The project thus becomes something subjective, not the result of deductive logic, but an unconscious activity where an idea is "grafted" onto reality, altering its meaning.

In Exodus, the Wall and the reality it creates are central, but so too is the memory of radical architecture.

The combination of these "experiences" translates into an image that is not utopia, but theory - much like in Superstudio's projects. Whether this image is realizable or not is irrelevant; its value lies in its role as a critical interpretation of the reality it represents.

## CONCLUSIONS: TOWARDS A NEW CHANCE OF THE ITALIAN THINKING

There is a profound difference between the projects of Superstudio and those of Rem Koolhaas.

In Koolhaas's work, no ideological stance or judgmental intent is overt; the lessons of the architectural "masters" and of reality itself are read, absorbed, and reimagined without moralistic undertones. Exodus, for example, does not evoke the forbidding wall dividing Berlin but rather functions as a conceptual "spaceship" akin to Superstudio's Continuous Monument - a structure that doesn't sever the historical city but instead lands upon it, in this case, on London.

In Exodus, unlike Superstudio's 2000-Ton City, people are not confined against their will; rather, they choose to enclose themselves voluntarily to unleash their instincts (even the most brutal) in an exaggerated form of freedom. This setup parodies the plight of Berliners attempting to flee from East to West: like all parodies, it replaces tragedy with irony, possibly alluding to the universal human impulse to escape from the socialist utopia (the radicals' political ideal) to the capitalist reality - an object of frequent critique by those same radicals. For Koolhaas, capitalism is not something an architect can condemn, but rather a reality to be understood, interpreted, and utilized. Instead of envisioning 12 ideal cities, the Dutch architect creates one: a Delirious New York, a conceptual territory that becomes the foundation for his lifelong architectural work. As Koolhaas himself stated, «I wanted to build, as

a writer, a territory where (...) I could eventually work as an architect» (Koolhaas 1993, 297).

With hindsight, it would be easy to say that the radical architects were right and Koolhaas wrong. The political, social, economic and environmental crisis that we are experiencing on a planetary level is certainly a sign of the failure of development models, first and foremost the capitalist one, that are rooted in the culture of modernity. Perhaps, as we have said, this new crisis of modern thought is the main reason for the rediscovery of the radical experience, especially the Italian one. But in order for this rediscovery, in architecture, not to simply translate into a new escape into the world of 'small things' and instead become the foundation of an 'operative' thought, it is necessary to understand the possibility of constructing a theory from utopia.

Among the 12 ideal cities envisioned by Superstudio, two stand out as embodiments of the meaning and future of the radical experience. The first is the spaceship city, symbolizing a transitional generation - the radical architects - condemned to inaction, awaiting the right conditions for their ideas to become feasible. The second, perhaps more significant, is the thirteenth city, introduced in the epilogue of a document published in Casabella. This city cannot be visually represented because it is invisible; its form can only be sensed through the shadow that appears in special circumstances. In this place of lost traces, all those who question the meaning of the 12 ideal cities come together, highlighting the theoretical legacy of the radical movement - a seed for what could become true postmodern architecture

*Gradually, only a few remained on the plain, as the others were preoccupied with building or inhabiting heavy and impossible cities. In the supposed place of origin of the thirteenth city, they began to reflect on the meaning of their memories and prophecies, attempting to reconstruct the reasons behind their*

*recollections and the plans for that city and the preceding twelve. Slowly, they came to realize that these were neither suppositions nor plans, nor descriptions written in some strange code. They were not metaphors or parables. In the end, they added a note on the how and why of these tales. The note read: 'We return the data you have provided us with (Natalini A. 2014).*

Koolhaas stands out as one of the few architects who has successfully gathered and utilized data, transforming it into a theoretical framework that has, for over fifty years, served as a lens for reading, interpreting, and shaping the contemporary city. The identity of Italian architecture, by contrast, has often been defined by a quest for a "necessary" theory to fill the voids left by professional practice over the past two decades (Valenti, Andreola, 175). Yet this "necessity" has frequently led to a growing disconnect between theoretical research and practical application.

The current revival of radical architecture - a movement that anticipated the crisis of modernity - is legitimized by the disruption of political, social, environmental, and economic stability in today's world. However, it is equally "necessary" that this rediscovery of Global Tools research does not devolve into a purely theoretical exercise. This is why, in this article, we aim to push the starting line forward, illustrating how the relationship between Koolhaas and radical architecture is not merely symbolic but exemplifies how "Italian-style" theoretical inquiry can be applied in a truly operational way. Here, utopia is no longer an escape from reality but becomes its critical interpretation, providing an essential framework for its reimagining.

As Marco Biraghi observes, "Koolhaas's point of view has always been marked as postmodern; where the term does not signify any stylistic character, but rather the thinkable condition of an alternative, more diverse and fluid modernity - a second chance afforded to modern culture and architecture" (Biraghi 2008).

## BIBLIOGRAPHY

COLOMINA, Beatriz., Learning from Global Tools. In BORGONUOVO Valerio, Silvia FRANCESCHINI. *Global Tools 1973-1975. When education coincides with life*. Roma: Nero, 2018, pp. 6-7. ISBN 978-88-8056-052-4.

BIRAGHI, Marco. Pier Vittorio Aureli, ovvero l'autonomia della teoria. 2016. <https://www.quodlibet.it/recensione/2472>

BIRAGHI, Marco. *Storia dell'architettura contemporanea II*. Milano: Einaudi, 2008.

DE FLEGO, Giovanni. La fine della storia, Utopia critica nelle 12 città ideali di superstudio, Tesi di Dottorato, Università degli Studi di Trieste XXVIII Ciclo del Dottorato di Ricerca in Ingegneria e Architettura Indirizzo Architettura, 2016.

DE FUSCO, Renato. *Realismo vs finzionismo*. In MALCOVATI Silvia, Federica VISCONTI, Michele CAJA, Renato CAPOZZI, Gaetano. FUSCO. *Architettura e realismo*. Napoli:Clean, 2012, p.292.

DE FUSCO, Renato. *Storia dell'architettura contemporanea*. Roma-Bari: Laterza Roma 1992.

GREGOTTI, Vittorio. *Necessità della teoria*. In Casabella. 1983 n. 494.

JENKS, Charles. (2014), *Storia del Post-modernismo*. Toronto: Postmedia, 2014 p. 192.

LA PIETRA, Ugo. *Abitare la città. Ricerche, interventi, progetti nello spazio urbano dal 1962 al 1982*. Firenze:Alinea, 1983.

ÖZAY, Özkan. Strategic way of designing in Rem Koolhaas Parc del La Villette project.2008. Resource: [etd.lib.metu.edu.tr/upload/12610287/index.pdf](http://etd.lib.metu.edu.tr/upload/12610287/index.pdf)

KOOLHAAS, Rem. *Field Trip. A(A) Memoir (First and Last...)*, trad. it. Gita Scolastica. In KOOLHAAS Rem. *Testi sulla non più città*. Roma: Quodlibet, 2021.

KOOLHAAS, Rem. The generic city. In KOOLHAAS Rem. *SMLXL*. New York: MITPress. 1994, pp.1248-1264.

KOOLHAAS, Rem. Why I wrote DNY and Other Textual Strategies. In Any,1993, cit. in KOOLHAAS Rem. *Delirious New York*, Italian Edition 2001. Oxford: Oxford University Press,1978.

NATALINI, Adolfo. *Superstudio - La Moglie di Lot*. 2014. <https://www.pinksummer.com/comunicato-superstudio-la-moglie-di-lot/>

VALENTI, Ilaria; ANDREOLI, Florencia. *Necessità della teoria: la ricerca italiana recente tra frammentarietà, ricorsi e ricostruzione critica*, in *ARDETH #01*, 2017, pp. 163-180.

## NOTES

1. The difference between a chronicle and history, as intended here, is that the former records daily news, while the latter focuses on past events and builds theoretical interpretations of those events.



# Was Skarphéðinn Jóhannsson a radical architect?

If so, in what sense?

róttækni  
samhengi  
samfélag  
menning  
náttúra  
**radical**  
**context**  
**society**  
**culture**  
**nature**

Byggingarlist hefur áhrif á líf fólks. Hún mótar hreyfingar okkar, rammur inn sjónarhorn og tengsl inni-úti. Hún veitir rúm fyrir athafnir, þarfir og frístundir. Þegar Skarphéðinn Jóhannsson fæddist 1914 á Íslandi var landið byggt á gildum landbúnaði og engin raunveruleg borgarmyndun til staðar. Á smærri mælikvarða var svefnherbergi ekki einu sinni talið nauðsynlegt í húsnæði. Á æskuárum hans voru salerni sjaldgæf eða jafnvel ekki til staðar. Búfenaður var algengur í landi Reykjavíkur. Meira að segja árið 1952, það hann föður sinn að leita að íbúð fyrir þá tvo, sem hefði eldhús.

Skarphéðinn opnaði teiknistofu sína í Reykjavík árið 1952, 38 ára gamall, þá ebonisti og arkitekt frá Kaupmannahöfn, lærður frá Kunsthandværkerskolen (1935-1938) og Kunstakademiets Arkitektskole (1945-1949). Hann hafði einnig starfað á arkitektaskrifstofu Kaare Klints í Kaupmannahöfn (1950) og ferðast um Ítalíu, Grand Tour, í eitt ár (1951). Slíkur bakgrunnur vekur upp spurningar um hvort tillögur Skarphéðins geti talist róttækar á Íslandi. Eða lá styrkur hans, ásamt öðrum íslenskum arkitektum, í að nútímavæða landið og ýta undir framþróun samfélagsins?

Rök verða lögð fyrir því að í þessu íslenska samhengi bjó Skarphéðinn til róttækar húsagerðir byggðar á afstæðum gildum og sem urðu hvati og nokkurs konar leiðarvísir að endurskilgreiningu arkitektúrs út frá menningu, samfélagsmyndun og náttúru. Nokkurs konar félags- og menningarmannfræði þar sem efniskennnd, umhverfi og félagslegar tengingar eru samtvinnaðar hönnunarþáttum arkitektúrs.

Architecture affects people's lives. It shapes our movement, frames our visions and relationship between inside – outside. It provides spaces for activities, needs, and leisure. When Skarphéðinn Jóhannsson was born 1914 in Iceland, the country was based on agrarian principles and with no real sense of a city. On a smaller scale, a bedroom was not even considered necessary in a dwelling. During his childhood, toilets were scarce or non-existent and livestock was common in the village of Reykjavík. Even at the beginning of 1952, Skarphéðinn asked his father to look for a decent flat for the two of them, which would have a kitchen.

Skarphéðinn opened his office in Reykjavík in 1952, aged 38 years; before then he had studied to become an ebonist and architect at Copenhagen, the Kunsthandværkerskolen (1935-1938) and Kunstakademiets Arkitektskole (1945-1949). He had also worked in Kaare Klint's architecture office in Copenhagen (1950) and spent a year on a Grand Tour in Italy (1951). With such a background, it will be reflected on whether Skarphéðinn's proposals can be considered radical in Iceland? Or was he, together with fellow architects, modernising the country and responding with an architecture elevating the society?

In this Icelandic context, it will be argued that Skarphéðinn surely created typologies that were radical in ways based on relative values and guidelines of redefining architecture through culture, society and Nature. A kind of cultural anthropology, where physical character, environmental and social relations, and culture are part of the architectural project.

**Arnardóttir, Halldóra<sup>1</sup>**

<sup>1</sup> University of the Arts, Department of Arts Education, Reykjavík, Iceland.  
<https://orcid.org/0009-0005-4063-0941>  
halldoraa@lhi.is

Citation: Arnardóttir, H. (2024). "Was Skarphéðinn Jóhannsson a radical architect?", UOU scientific journal #08, 42-51.

ISSN: 2697-1518. <https://doi.org/10.14198/UOU.2024.8.06>  
This document is under a Creative Commons Attribution 4.0 International license (CC BY 4.0)

Article Received: 15/09/2024  
Received in revised form: 02/11/2024  
Accepted: 02/11/2024



## INTRODUCTION

When the author was encouraged to write an article for the issue on Radical architecture, it started a series of reflections on what constitutes such a concept. Certainly, Radical architecture is known as a concept and often attributed to Andrea Branzi's thought in the sixties where he says:

*Radical architecture forms part of a wider movement for man's liberation from the tendencies of contemporary culture; individual liberation understood as the rejection of all formal and moral parameters, which, acting like inhibiting structures, hinder the individual's total fulfilment. In this sense, the term, radical architecture, denotes a cultural place rather than unitary movement* (Jarauta, 2023, 134).

A question mark is placed to whether the Icelandic architect Skarphéðinn Jóhannsson (1914-1970) can be seen within this context of radicalism. When he returned to Iceland after his studies and Grand Tour in 1952, his membership in the Iceland Architectural Association was number 26. Modern architecture was practiced by few, yet one could agree with Jarauta that "What was at stake was the defence of a new social use of culture against the global project of a new interpretation of the modern." (Jarauta, 2023, 133).

Searching for answers on Skarphéðinn's radicalism, a thorough observation was laid out on his thoughts, a kind "thinking through mapping". It began by getting to know the man through hundreds of letters he wrote home from where he studied in Copenhagen, then his letters from Italy in 1951 were examined in which he expressed his opinions on what he saw and listened to. Through his pen, he seemed to think and used correspondence for reflection and conversation on architecture and cultural issues. Along with this work, mind maps were made at different points in the process. It became a kind of working atlas, a collection of maps that

gave hints on different realities. His writings and sketches became the grounds for rethinking "the internal relationship which governs the idea of inhabitation and its construction." (Jarauta, 2023, 137).

During the time of Skarphéðinn's practice (1952-1970), the initial steps were being taken for making the city of Reykjavík. Radical changes of attitude were foreseen of how to live in a city. Skarphéðinn was part of the transformation. His radicalism lay partly, in his sensitivity and skills of observation. His design of buildings came from sociological surveys, but also from research on other cultures – Italy – noting patterns of use between buildings and space/context, like an anthropologist. From these researches, he transmuted them into design in another culture – Iceland.

## SKARPHÉÐINN JÓHANSSON, HIS BACKGROUND

Skarphéðinn Jóhannsson was born in Iceland in the year 1914 and was brought up with respect for hard work and responsibility, a commitment of doing his best for his country. He was raised by his parents in the spirit of the youth movement, the set of values that laid in working wholeheartedly for the progress and well-being of oneself, the country, and its people. In a letter to his father from Copenhagen in February 1949, Skarphéðinn recalled what his father had taught him in his childhood. It was to treat the poor well and be aware of the fact that there are those who live difficult lives, and whom we have a duty to help, if it is in our power.<sup>1</sup>

During Skarphéðinn's childhood, the population of Reykjavík was just over 4,000. In 1916, a book by the doctor Guðmundur Hannesson, *On town planning*, was published. There he argued, for the first time in Iceland, that towns should be planned with regard to the health and well-being of their inhabitants. Factors such as good daylight and access to clean water were

essential. There was a direct link between clean drinking water and diseases such as typhoid fever. Roads in Reykjavík were made of gravel and a sewer system gradually took shape. Water supply had come in 1909. The number of water closets increased, depending on the means and circumstances of the families. According to a report about toilets from 1926, in Reykjavík, there were 1.294 outdoor toilets and 1.155 water toilets (Friðriksson, 81) Skarphéðinn was 12 years old then. The development of the town was therefore a response to the increased need for hygiene, clean water, fresh air, and more spacious and brighter apartments.

Skarphéðinn Jóhannsson is one of the key figures amongst architects who introduced modernity into the Icelandic society through his furniture designs and interior fittings, writings, and buildings. His work is interwoven with the cultural and economic history of the country. One must also remember that during the Second World War, the country was still under the rule of Denmark,<sup>2</sup> and a great number of people moved from the countryside to start a new life in Reykjavík. Due to the British occupation in 1940 and a year later the USA army, the demand for workforce in Reykjavík increased immensely. Roads and airports were built but also there was a need for services like laundry washing for the army forces.

This raised questions on modernity both in terms of industrial production and civil society, in a country that was still based on rural values and in great need of housing in Reykjavík. In fact, Skarphéðinn won the First Prize in a furniture competition for farmers' homes in 1939. The proposal showed light furniture (easy to move around), simple forms, easy to clean and care for. He had written fiercely in the newspapers to reach the general public on the need for furniture and interior designs that were closer to functional use than reduced to uncomfortable decoration. He proclaimed that domestic settings needed to be easier to manage and of better quality.<sup>3</sup> Furniture designs he made

for the domestic management school in Reykjavík, in 1941, are still in use more than 80 years later.

## SKARPHÉÐINN'S FORMATIVE YEARS 1945 TO 1952

Skarphéðinn had always been a keen observer, whether in Nature, in the city or even drawing caricatures of his friends. From when he was a young man, he travelled extensively on a pair of skis in Iceland's mountains and glaciers, and published observations that later scientists referred to in their articles on the development of glaciers. Nature was an engaging place, a place of reflection. In the city, during his Grand Tour around Italy in 1951, he sat long hours drawing details of squares and buildings, contemplating people's behaviour and social life, observing. Skarphéðinn documented the journey in travel diaries in the form of hundreds of letters, drawings and photographs. He wrote to his father two or three times a week, making reference to the city urban fabric, history and culture, people's behaviour in public spaces and streets, as well as social relationships. The letters were his forms of not forgetting. He had a reflective character, about himself and who he was, detecting cultural differences between Iceland, Denmark and Italy, wanting to learn from others and to give Nature a voice, have Her as mentor.

Skarphéðinn began his architecture studies in the autumn of 1945, just a year after Iceland became independent from Denmark. When embarking on his studies at Copenhagen in the *Kunstakademiets Arkitektskole*, he was fully aware of the importance of expanding his knowledge and to contribute to the modernization of dwellings, industrial production facilities and work conditions upon his return.

During his academic years in *Kunstakademiets* he also received practical experience in Kaare Klint's architecture office, he learnt about typologies (dwellings,

banks, schools, churches etc.), ways of thinking and selecting materials, context and function, light and orientation. On a number of occasions Skarphéðinn chose Icelandic themes for his student projects. Here one could draw attention to a tourist hotel with a spa or Iceland National Art Museum. Both of which he took great care in moulding to the preexisting landscape and which were new typologies in the country. Furthermore, he took commissions in Iceland that enabled him to finance his studies, as for instance, furniture designs for *Búnaðarbankinn* (Bank of Agriculture) or a summer house by *Elliðavatn* in the outskirts of Reykjavík. On that drawing he emphasised the importance to choose materials for the interior that would enhance the feeling for being in Nature.

## SKARPHÉÐINN'S HOMECOMING 1952

Skarphéðinn knew architects' working environment well upon his return to Iceland in 1952. He had already earned respect in society from influential people in the diary product industry, steel and electronic, as well as Iceland's Oil Trade company and education authorities. His office became one of the most sought after, leaving behind hundreds of projects when Skarphéðinn died prematurely in 1970 from cancer. These projects included buildings, furniture, interiors, and exhibition designs. Iceland needed new schools, factories, offices spaces, banks, research laboratories, single dwellings as well as a new image abroad and at home. Many were done in collaboration with his wife, Kristín Guðmundsdóttir (1923-2016), who had a degree in Interior Design from Northwestern University in Chicago.<sup>4</sup>

At the age of 38, Skarphéðinn felt ready to return home and leave his formative years behind. He had gained experience and knowledge abroad which he wanted to follow up in his projects. Would he be understood? Prior to formulating

a project in drawing, he devoted himself to preparatory work, which involved acquiring knowledge about the culture of his clients and seeking experience from experts even abroad. Study trips were thus taken for selected projects. It was essential to understand the social issues in order to rethink the architectural proposal for a new age. Iceland was going through great changes linked to the conditions deriving from the cultural changes in human inhabitation, conditions that Francisco Jarauta rightly draws out in his article, *Questioning Contemporary Architecture*, as a decisive force architecture had to face (Jarauta, 2023, 129).

Below will be drawn out three fields of the architect Skarphéðinn, as a curator and designer of schools and single dwellings. Creating an image for a nation, a setting for the family, and the collective future through education. It will be argued that his architecture was radical in the sense of defending a new social use of culture in the architecture project against a global project of a new interpretation of the modern.

## The architect as a curator

One of the first commissions Skarphéðinn received in 1952 was to curate the Reykjavík Industrial Exhibition.

The exhibition had two main goals. Firstly, to demonstrate to the nation's authorities that the industry was surely to significantly increase employment opportunities, thus preventing unemployment and improving the nation's earning potential and economy. And, secondly, to eliminate the underestimation and misbelief which the general public had shown towards the importance, abilities and production of Icelandic industry.<sup>5</sup> Industry should be promoted, in other words, and its fields and products should be made more visible. Agriculture and fishing were no longer the nation's main means of employment. Already one third of the population lived on industry, directly or indirectly.



To achieve these aims of visibility and educate people about industrial products and restrain the purchase of unsophisticated foreign products, it was decided to organize an exhibition. Skarphéðinn was approached to design and curate the exhibition. He accepted

the challenge. He had seen a great diversity of exhibitions abroad and he had been fascinated by the way in which objects had been staged and put into context.

Here, in the Reykjavík Industrial Exhibition, he decided to create a small narrative in each stand,



from the technique and material to the realisation of the product and to the consumer. The setting was at the same time playful and often interactive. In that way, the visitors moved between over 200 short stories narrated in five level exhibition space (Fig.1 and 2).

More than a decade later, Skarphéðinn was selected to be one of the five architects to collaborate in the design of the Scandinavian pavilion in the Expo 67 in Montreal. Furthermore, he was commissioned to curate Iceland's exhibition. He and his team decided to reinterpret the culture of the water and show how Icelandic citizens use their hot water and its effects on their habitation. Additionally, a section was dedicated to volcanoes which had affected the lives of the island's inhabitants right from the days of first settlement. Skarphéðinn's initial question was around "What kind of people live in this country of ice and fire",<sup>6</sup> but refrained from cliché or already known facts. His answer lay in showing very normal people who had adjusted well in the hard living country by making use of technology and consumption (Fig.3 and 4).

Again here, Skarphéðinn brought real pieces from the Icelandic Nature to the exhibition – lava – that supported diagrams, models, photographs (so called "photographic linework") and scientific descriptions by Sigurður Þórarinnsson geologist, demonstrating how water had shaped people's inhabitation through the ages.

### The architect of Education Centres and Research

In 1956, Skarphéðinn was commissioned to design two grammar schools for the city of Reykjavík, Réttarholtsskóli and Hagaskóli. Great ambitions in terms of educational space as well as caring for students' mental health.

Action had to be taken because, although compulsory education

for 7 to 15 year old children had been legislated in 1946, in 1956 the law had been implemented in only 42 school districts out of 218 (Jóhannesson, 301-305). One of the main innovations of the education law was that vocational training was greatly increased. The practical training consisted of cooking, handicrafts, construction and visual arts. These subjects were intended to bridge the gap between the activities of daily life and general schooling as well as to connect with the practical skills that the country needed. The country of Iceland was far behind other neighbouring countries in terms of industry and craftsmanship. It was planned that all state-run schools would be equipped with special classrooms for cooking, crafts, construction and art. Sports facilities were also considered important at schools or in their vicinity when urban areas grew, including swimming facilities.

Another issue that was discussed within the field of education, was studies of Nature. Iceland was far behind in teaching and communicating material about Nature (Pétursson, 55-77). This was an important point as the country's culture is based on knowing Nature, its laws and character. In that way progress would be made. More value had to be placed upon learning through practical tasks, that children should learn to measure and examine in a practical way and not only theory. Schools should also be based on democratic values and equality, in the sense of raising children so that they receive an intellectual, practical education that is useful for society as well as for the home.

Within this context, the school building itself, its interior, materials and layout, should reinterpret this new social condition and benefit children's wellbeing, for teachers and staff alike.

The grammar schools, Réttarholtsskóli and Hagaskóli, were designed simultaneously and were to be built in stages. Skarphéðinn interpreted these social expectations by designing buildings where honesty and purpose

prevailed in construction. Structure and materials were made visible in simple forms and proportions, and textures of materials. Furthermore, Nature became an integral part of the design, for the sake of respect, learning environment and appreciating beauty. This,

Skarphéðinn believed, would be reflected in a culture of habitation inside and outside the home

Before starting the design process, Skarphéðinn together with a group of educators, went to visit new schools in Denmark and Sweden.

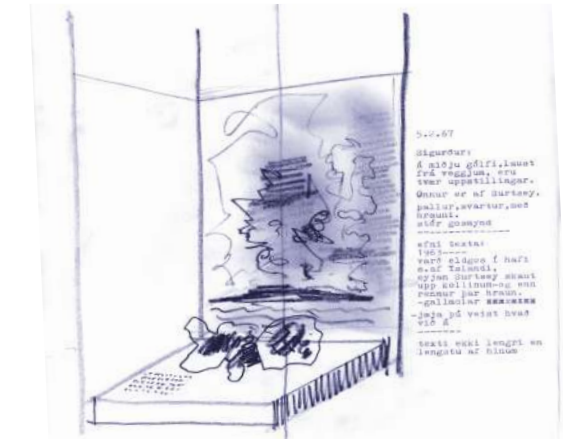

Fig.1 and 2 - The industrial exhibition in 1952 at the Reykjavík Polytechnic School. Curator and exhibition designer: Skarphéðinn Jóhannsson. Skarphéðinn had paid special attention to museums during his travels through Europe. In particular, how objects were arranged and put into context, their "natural environment". The exhibition visitors were made active participants and children could even try the bicycles in the case of the stand with Fálkinn's productions (© Reykjavík Photography Museum. Photographer: Amatörvinnustofa G. Ásgeirssonar).

Fig.3. and 4 - Montreal '67, Expo. Sketches and real model: volcanic eruption and real lava. In the background on the wall are so called "photographic linework" by Rafn Hafnfjörð photographer (© Hornsteinar architects).



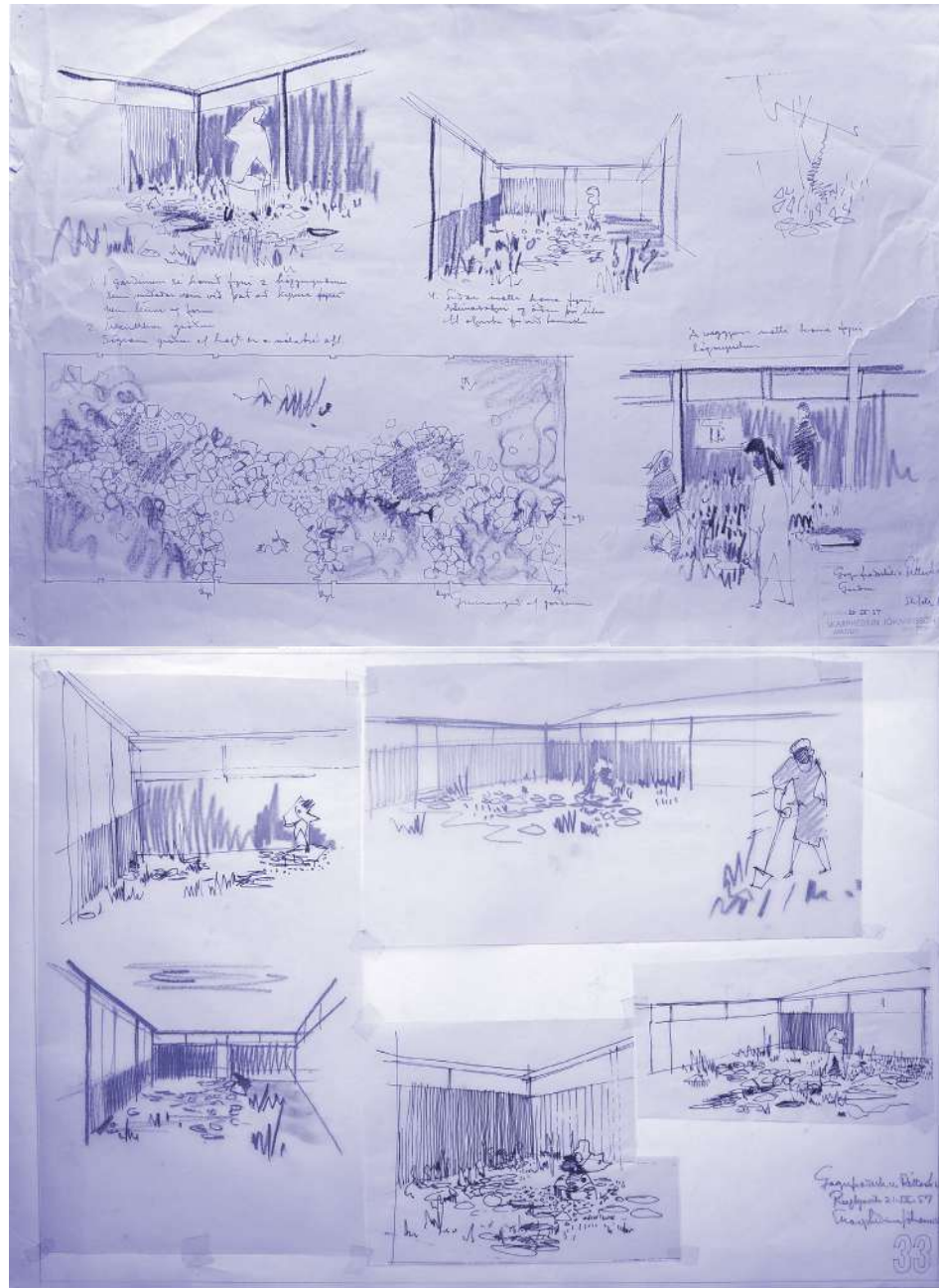

Fig.5 and 6 - Sketches for the elementary schools Réttarholtsskóli and Hagaskóli Reykjavík, 1957, of internal patios for practical classes in natural science. Skarphéðinn proposed two versions; one garden based on native plants and another on Icelandic stones. In both cases, Skarphéðinn played with colours, forms and textures from both the built materials, sculptures and plants (© Hornsteinar architects).

Among them was Munkegårdskolen designed by Arne Jakobsen which Skarphéðinn considered outstanding.<sup>7</sup>

Points that he noted in his notebook regarded typology, access to the schools and their gardens, shelter from traffic, winds and weather, heating and fittings such as for windows and ceilings for the sake of acoustics. A few such elements were translated into Skarphéðinn's schools in Reykjavík. These include wide corridors, educational gardens between the

school wings with a direct access from the classrooms, large windows with curtains for the lower part and built-in blinds for the upper part.

There were two exits in the classrooms, to the corridor and to the garden. Windows faced the garden. Great care was taken with acoustics. There were soundproof panels in the ceilings of the classrooms. In the corridors there were wooden ceilings and vinyl flooring. The cost of maintenance was low.



Fig.7 - Newly built Réttarholtsskóli, first phase. The construction started in May 1957 and teaching started in 8 classrooms the same autumn. Characteristic is the raw concrete and composition of windows, as well as how the light is brought into the building from above (© Reykjavík Photography Museum. Photographer: Pétur Thomsen 1910-1988).

Both schools, Réttarholtsskóli and Hagaskóli, were designed partly on two levels. Connected wings created a core around an open play area and the educational gardens between the wings (Fig.5 and 6). Skarphéðinn envisioned that the buildings would be built around a playground so that the best possible shelter and privacy would be provided for the children. Playgrounds were to be located according to weather conditions. In this context, it is interesting to remember that shade was one of the factors that attracted Skarphéðinn's attention during his travels in Italy. In summer, the sun heated both the air and the squares, often with dramatic consequences. In those conditions, the city dwellers looked for shade, and in doing so, social relations were strengthened and the quality of life improved. In the Reykjavík's schools, Skarphéðinn rethought this element by finding shelter from the wind (Fig.7).

Here the words of the Swiss architect Alfred Roth apply well, as he writes about school buildings in his book *The New School*. That book was published in 1950 and Skarphéðinn had it in his office. Roth emphasized a healthy environment in and around the school building with areas for sports, outdoor games and exercise. Shelter from the wind would be provided by nearby houses and vegetation. The school would be an extension of the home in a way. Therefore, classrooms should be

cozy and friendly, and mental well-being should be nurtured. That attitude would apply equally to students as well as teachers and other staff. Care was taken in the working environment.

Skarphéðinn's school buildings set the tone for the educational buildings of tomorrow, a kind of guidelines for the future. He became the architect of many schools in Reykjavík and elsewhere. Among them are Hvassaleitisskóli, the secondary school at Hamrahlíð, a school for children with impaired hearing, university faculties, research centres, and laboratories.

## The architect and the single dwelling

Skarphéðinn worked on different scales simultaneously. He designed several houses, often for collaborators or for people who held positions in society and were expected to invite guests home for

formal dinners. There were still very few restaurants in Reykjavík in the fifties and sixties. One of his radical solutions for a family dwelling was designed in 1955. It was expected to fulfil the needs of a family house and at the same time to be a place of reception for up to hundred and twenty guests and twenty-eight sitting for dinner.

Many of his designs for dwellings therefore had a dual function for his clients, being a home for the family and a meeting place for a specific community. The dwelling was a window to the outside and became a reference for modernity and modern designed homes. It is worth remembering that more than 2.000 people still lived in barracks at this time that the British and American armies had left behind. They were in many parts of Reykjavík while new neighborhoods were being built. The last barrack as a dwelling was not demolished until around 1970. Immense visual contrasts

characterized therefore housing in Reykjavík. Builders and architects had enormous influence on the quality of life and ways of living.

One of the houses Skarphéðinn designed is now protected by the National Heritage in Iceland.<sup>8</sup> Bergstaðastræti 70 from 1957 was built for a furniture designer and his wife, a historian (Fig.8).

Before starting the design process, Skarphéðinn raised scaffolding on the site to find out the best views and viewpoints. The plot was small and tight to neighbouring houses, only 398 square meters, so it was not easy to accommodate a house that would meet the expectations and needs of the family.

The result was to use the potential of the plot and the view to the south over the nearby houses and treetops, the living spaces had to be planned on the upper floor and the sleeping area on the lower one. The difference in height on the plot was



Fig.8 - The house is singular for its respect for the preexisting environment in grown street, receding from the street and creating a sheltering entrance from the wind and rain (© The Cultural Heritage Agency of Iceland)



used for the benefit of the family, and the spaces were organized according to use and the optimum light during the 24 hours.

The simple form of a house is broken up on the street side. The house recedes from the street and entry, and although the garage is connected to the house, it is not fully visible until you reach it on the pavement. A basement flat under the garage is not visible from the street. It has views to the garden. The kitchen looks out onto the street, designed by the furniture designer himself, while the dining room and other sitting rooms are along the south wall with panoramic views over the neighbouring houses. Downstairs, the bedrooms overlook the garden. The wall between the dining room and living room is covered with red stone slabs on both sides.

The house is singular for its setting and respect for the preexisting environment in an established street. A conclusion which can be drawn bearing in mind his comments made from his observations in Italy, where different periods of buildings generally characterized the streets and amphitheatres were placed as to draw out the qualities of the site and its views. Yet, it redefined the architecture through the culture of the clients. This house was thus radically new to Iceland in several ways. Primarily in its integration with an existing street - International Style Modernist buildings were typically free-standing objects - and the radical making of such a large protected entrance from wind and rain, or at least a radical departure from International Modernism.

Another house of a very different kind was that made for an engineer and his family in Álftanes near Reykjavík. The house Hraungarðar designed in 1955 in close collaboration with the clients, merges into the Nature surroundings of the lava (Fig.9). Together with specific needs, the clients provided the architect with a map of viewpoints and timings that showed specific directions towards



Fig.9 - Building within a context of the client, culture and wishes, as well as the characteristics of the site (© Reykjavík Photography Museum. Photographer: Pétur Thomsen 1910-1988).

the mountains. The family wished to place the house in this context and its rooms in line with the lava and mountain views along the day.

Hraungarðar became an opportunity for rethinking the setting for human actions where the dialogue between architecture and landscape was a response to reinterpreting culture of the modern age.

## SKARPHÉÐINN'S RADICALISM

Returning to the title of this article, whether Skarphéðinn Jóhannsson was a radical architect and if so, in what sense, it becomes clear that the territory this architect worked within, the formation of a city, was a subject of the central discussion of rethinking architecture and its typologies for new demands. Skarphéðinn took action in rethinking the culture of living and working, through sociology and anthropology - his own country and other cultures.

He took the liberty of reinterpreting modernity in relation to what was becoming the industrial city of Reykjavík. In that context, his radicalism is identified in his way of rethinking architectural norms in particular incorporating Nature into the architectural project. These new kind of spaces and typologies

included among others, education centres, dwellings, summer houses, industrial buildings, reshaping Iceland's image at home and abroad.

The architectural project became a meeting between places, and identifying the social, cultural, technical and natural relationship between man's dominion and Nature (Fig.10 and 11).

In his competition proposals, of which he won first prizes, the building and garden, were equally important. This could be seen in a proposal for the Iceland Central bank and for nursery schools.

In the international context, one can also argue that he was radical in

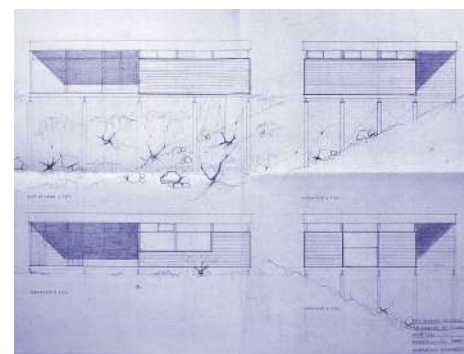

Fig.10 - Summer house by the lake Þingvellir for Haraldur Björnsson (© Hornsteinar architects)

The architectural project became a meeting between places, and identifying the social, cultural, technical and natural relationship between man's dominion and Nature.

his self-education through his letter writing and reflections. He firmly believed his formative years had not ended until he had completed the practical training in Kaare Klint's office and spent a year travelling around Italy, giving himself time to observe Italian culture, architecture heritage and a particular people's social behaviour in the different cities.

Here it has been suggested that perhaps the truest description of Skarphéðinn, as an architect and active member of the society he designed for, is to say he was a radical architect based on social and anthropological values. Not only about fulfilling basic needs for modern dwelling but reinterpreting culture.

For Skarphéðinn, architecture was an opportunity for rethinking the setting for human actions where the dialogue between architecture and Nature was a response to reinterpreting culture of the modern man. In that sense, Skarphéðinn was ahead of his time, and Branzi's words above can be adopted, understanding radical architecture as a cultural place.

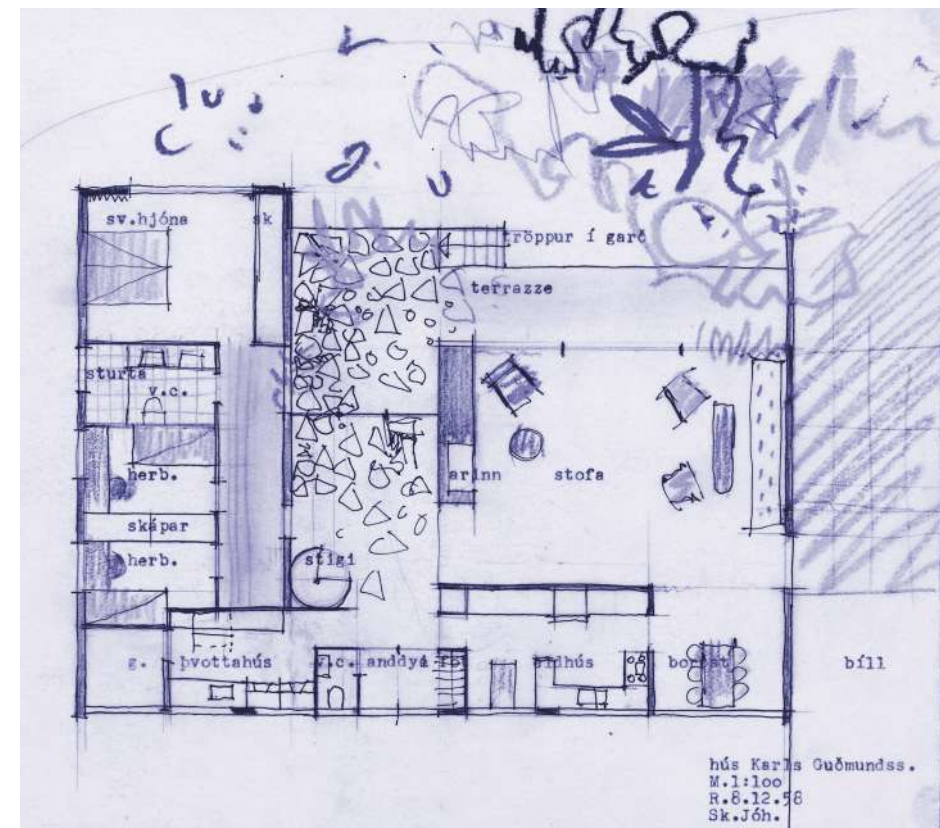

Fig.11 - A sketch proposal for a house in 1958 which clearly shows how Nature enters the interior domain and becomes part of the home (© Hornsteinar architects).

## BIBLIOGRAPHY

- Arnardóttir, Halldóra (ed). 2015. *Kristín Guðmundsdóttir hífylfræðingur/ interior designer*. Reykjavík. Hið íslenska bókmenntafélag. ISBN : 9789979663300
- Berg, Helgi. Iðnsýningin 1952. In *Samtíðinn*. September 1952, pp 3-4.
- Friðriksson, Guðjón. *Cloacina. Saga fráveitu*. Reykjavík Veitur. 2021.
- Hannesson, Guðmundur. *Um skipulag bæja*. Reykjavík. Háskólaútgáfan. 2017.
- IaN + Baglivo C., Galofaro, L. New Ecology of the Living System. In *Arquitectura Radical / Radical Architecture*. Centro Atlantico de Arte Moderno. Ed. de Umbral. 2003. pp 119-129.
- Jarauta, Francisco. Questioning Contemporary Architecture. In *Arquitectura Radical / Radical Architecture*. Centro Atlantico de Arte Moderno. Ediciones de Umbral. 2003. 129-139. ISBN: 84-89152-66-7.
- Jóhannesson, Ingimar. Ýmislegt um skólamál 1944-1957. In *Menntamál. Tímarit um uppeldis- og fræðslumál*, 1957, 3. Tbl. 1. des. pp 301-305.
- Jóhannesson, Skarphéðinn and Hallgrímsson, Helgi. Hlutirnir sem skapa heimilin. Um húsgögn I. In *Morgunblaðið* 7. janúar 1939. p 4.
- Jóhannesson, Skarphéðinn. Dagstofan. Um húsgögn III. In *Morgunblaðið*. 9. febrúar 1939. p 4.
- Jóhannesson, Skarphéðinn. Heimili og húsgögn. In *Húsakostur og hífylaprýði*. Reykjavík. Mál og menning, 1939. pp 83-92.

Jóhannesson, Skarphéðinn. Húsbúnaður. In *Heimilið og Kron*. Blað Kaupfélags Reykjavíkur og nágrennis. III. árg. 8.-9. Tbl ágúst-sept. 1940. pp 74-77.

N.N. Til iðnaðarmanna. In *Tímarit iðnaðarmanna*. 1952. 3. Tbl. 25. árg. n.p.

Pétursson, Sigurður. Nám í náttúrufræðum á Íslandi. In *Menntamál*. I. árg. Tbl 2. maí-desember 1958, pp 55-77.

Roth, Albert. *The New School*. Zurich, Editions Girsberger, 1950.

## NOTES

1. The research for this article is to a large extent based on original material taken from Skarphéðinn's archive. The author has had a private access to this material stored in architecture office Hornsteinar in Reykjavík, where Skarphéðinn's original drawings are also kept from his students years and professional work. This article is based on a book manuscript on the architect hoped to be published in the year 2025. Research funding include: Design Funding Ministry of Culture and Education, The Icelandic Centre for Research - RANNÍS, Architectural Heritage Fund, Hagþenkir - Association of non-fiction writers, Reykjavík city Council Visual Storytelling Grant, and Memorial Fund Guðjón Samúelsson. Hornsteinar gave permission for the visual material from Skarphéðinn's archive.

2. The founding of the Republic of Iceland was declared in 1944 when Denmark was still occupied by Nazi Germany.

3. See to name only a few: Jóhannesson, Skarphéðinn and Hallgrímsson, Helgi. Hlutirnir sem skapa heimilin. Um húsgögn I. In *Morgunblaðið*, 7 January 1939, p 4.

Jóhannesson, Skarphéðinn. Dagstofan. Um húsgögn III. *Morgunblaðið*, 9 February 1939, p 4.

The book chapter, Jóhannesson, Skarphéðinn. Heimili og húsgögn. In *Húsakostur og hífylaprýði*. Reykjavík. Mál og menning, 1939, pp 83-92.

Jóhannesson, Skarphéðinn. Húsbúnaður. *Heimilið og Kron*. Blað Kaupfélags Reykjavíkur og nágrennis. III. árg. 8.-9. Tbl August-September, 1940, pp 74-77.

4. Halldóra Arnardóttir (ed). 2015. *Kristín Guðmundsdóttir hífylfræðingur/ interior designer*. Reykjavík. Hið íslenska bókmenntafélag.

5. See articles, N.N. Til iðnaðarmanna. *Tímarit iðnaðarmanna*. 3. hefti. 25. árg. 1952 and Berg, Helgi. Iðnsýningin 1952. In *Samtíðinn*. September 1952, pp 3-4.

6. The quote is taken from a handwritten text written on one of Skarphéðinn's working sketches for the exhibition.

7. Skarphéðinn kept a diary on this trip and wrote down pro and contra of all the schools they visited. Some of which he incorporated into his designs.

8. See The Cultural Heritage Agency of Iceland website: <https://www.minjastofnun.is/is/byggingararfur/fridlyst-hus-og-mannvirki/bergstadastraeti-70>



**RADICAL**

**URBANISM**



# Oswald Mathias Ungers in Berlin

Research, project and experimentation

Berlino  
Ungers  
ricostruzione della città  
architettura radicale  
ricerca urbana  
**Berlin  
Ungers  
city reconstruction  
radical architecture  
urban research**

*In The City within the City: Berlin as a green archipel* Ungers, insieme al suo gruppo di collaboratori tra cui Koolhaas, Riemann, Kollhoff e Ovaska, ha definito importanti visioni per la vita urbana e l'architettura che non furono mai realizzate, ma che hanno interessato con continuità il dibattito architettonico, soprattutto nell'ultimo decennio. Guardata retrospettivamente, la Sommer Akademie tenutasi a Berlino nel 1977 appare oggi come la scena primordiale della nostra architettura contemporanea e del nostro modo di guardare allo sviluppo delle città. L'obiettivo del contributo non è discutere di questo documento come oggetto di una ricerca storica ma tracciare i tratti generali della ricerca ungersiana sulla città in cui si collocano le riflessioni su Berlino, delineando i fattori principali che hanno influito sulla genesi dell'idea della *città arcipelago*. Dall'altro lato il contributo torna a parlare di *città arcipelago* nella convinzione che possa ancora costituire uno strumento significativo per costruire nuove narrative di progetto per la città di oggi.

*In The City within the City: Berlin as a Green Archipelago*, Ungers, along with his team of collaborators including Koolhaas, Riemann, Kollhoff, and Ovaska, defined important visions for urban life and architecture that were never realized but have continuously influenced architectural discourse, especially in the past decade. Viewed retrospectively, the Sommer Akademie held in Berlin in 1977 now appears as a primordial scene of our contemporary architecture and our way of looking at urban development. The aim of this contribution is not to discuss this document as an object of historical research but to outline the general aspects of Ungers' research on the city, within which the reflections on Berlin are situated, highlighting the main factors that influenced the genesis of the idea of *the city as an archipelago*. On the other hand, this contribution revisits the concept of *the city as an archipelago* with the belief that it can still serve as a meaningful tool for constructing new design narratives for today's cities.

**D'Alessandro, Martina<sup>1</sup>**

<sup>1</sup> University of Bologna, Department of Architecture, Bologna, Italy.  
<https://orcid.org/0000-0003-2586-2208>  
[martina.dalessandro2@unibo.it](mailto:martina.dalessandro2@unibo.it)

Citation: D'Alessandro, M. (2024). "Oswald Mathias Ungers in Berlin", UOU scientific journal #08, 54-65.

ISSN: 2697-1518. <https://doi.org/10.14198/UOU.2024.8.07>  
This document is under a Creative Commons Attribution 4.0 International license (CC BY 4.0)

Article Received: 12/09/2024  
Received in revised form: 02/10/2024  
Accepted: 28/10/2024





## INTRODUCTION

In the Berlin of the 1960s and 1970s, Oswald Mathias Ungers founded a laboratory for researching the form of the city and proposing a paradigm city for exploring the theme of urban reconstruction. The most radical contribution of Ungers' research for Berlin is the urban theory presented in *The City within the City: Berlin as a Green Archipelago*<sup>1</sup>, where he theorizes a hypothesis for reconfiguring the urban organism through general and large-scale strategies.

This document is part of the broader context of what are known as "site-specific manifestos," alongside works such as *Delirious New York* (Koolhaas, 1978) and *Learning from Las Vegas* (Scott Brown, Izenour, Venturi, 1972). It offers a specific urban vision for a specific city. A premise of this contribution is that, as is often the case, the completion of research cannot be defined by strict boundaries, either temporal or geographic. Ungers' ideas for Berlin arise from a complex process, evolving over time and informed by considerations, experiences, and experiments related to other cities as well.

Studying Ungers as an architect, theorist, and profound connoisseur of the art world inevitably involves comparing him with the architect-emperor Hadrian. Both build an ideal constellation of references, memories, and fields of research that accompany them throughout their lives. Emperor Hadrian established Villa Adriana in Tivoli, a *museum of ideas* where a prestigious collection of cherished architectures is gathered, preserved, and studied. Similarly, Ungers creates a geography of cities that condenses the research and experiments that shape his architectural practice and thought (Purini, 2020).

Trier, Cologne, and Berlin, viewed through this lens, represent cities of affection and experimentation of fundamental importance to the author. These cities are significant not only for their biographical roles

- Ungers was born in Kaisersesch, a small town near Trier. He considers Trier as his adopted city, lived and worked in Cologne, first in the Belvederestrasse studio-house and later in the Kämpchensweg house, and taught at the Technische Universität in Berlin - but also for their value in Ungers' architectural research.

Trier is the city from which Ungers derives the compositional principles that characterize his architecture, such as the interpretation of architecture as an assembly of forms, the idea of morphological continuity, and geometry as an autonomous expression of an absolute idea. The architecture of Trier demonstrates the ability to bring together diverse elements in one place without losing local identity and character. Trier vividly embodies the idea of the city as a composition of fragments: Roman, Romanesque, Gothic, Renaissance, and Baroque monuments coexist, maintaining their individuality as if they were variations on a single theme. In Trier, Ungers engages with the history that physically emerges from the city's ground. The archaeological projects that Ungers developed during his career are mostly concentrated in this city, making it a paradigmatic field for exploring the relationship between architecture and history (D'Alessandro, 2015).

Cologne represents a field of research about urban forms, developed through in-depth investigations and design experiments on an urban scale. For the city of Cologne OMU developed fifty-three projects, of which twenty-three were competitions and thirty built. Many of these projects, mainly focused on the theme of living, are condensed outside the historical urban core and build real pieces of the city. The project for the Neue Stadt district (1961-64) and the Grünzug Süd (1962-65) are paradigmatic examples of the author's urban vision, based on morphological investigations and experiments. At the same time, the great urban plans for the Euroforum (1992 and 1995) offered an opportunity to experiment

with morphological solutions and variations that define complex public urban spaces.

Through these important opportunities to build the city, which unfortunately often remained on paper, Ungers experimented and outlined his idea of the city: a city defined through form, transcending functional approaches. Form, and specifically urban form, is explored in its deepest spatial and morphological meanings. The development of urban projects represents an opportunity to design parts of the city that, regardless of the functional programme to which they refer, are configured as a *city within the city*. These recognisable urban forms are obtained through assemblages and aggregations of positive and negative forms, of built masses and empty spaces (D'Alessandro, 2022).

Rudolf Schwartz's studies on the urban structure of Cologne became fundamental precedents for Ungers' theory of *the city within the city* and his research on reconstruction for Berlin. In 1950, Schwartz published the reconstruction plan for Cologne (Stadt Köln, 1950) in which the city is composed of many cities: "We divided the old city into nine cities-in-the-city. We were helped by the fact that even before, the old city was divided into similar 'quarters,' though smaller, each strongly differentiated from one another by its social and productive composition; each with its main street, market, churches, schools, and traditions" (Schwartz, 2000).

Berlin, especially in the 1960s and 1970s, became a stage for theoretical, educational, and design experiments on urban structure. For Berlin, Ungers developed urban plans focused on the reading of urban form and the representation of its identity. His research was not aimed at definitive and univocal solutions but was embedded in possible scenarios, radicalizing the experimental value of his urban research. During these years, Berlin remained scarred by the destructions of the war and split into two halves. Ungers saw this condition as the ideal scenario

to experiment with his vision for Berlin, made up of fragments of autonomous and recognizable islands, as we will see later. In the 1980s, during the IBA and reconstruction years, Ungers had the opportunity to materialize his experiments in the reconstruction plans.

Even in this research stream, engagement with history is an unavoidable step in defining his theories. Schinkel's urban visions for Berlin become fundamental references for Ungers, who writes: "Berlin contains the concept of the city within the city as the result of the collective unconscious, conceptualized by Friedrich Wilhelm IV in the Havel landscape, a cultural landscape that allows such an idea to be conceptualized in a humanistic sense. The king wanted to transform the road from Berlin to Potsdam into an educational panorama, turning it into an archipelago of architectural events, inserting pieces of the memory of antiquity and examples of different cultures and historical eras into the landscape.

These fragments of the past, projected into the future, relate the past to the future in a continuum of collective memory. Each architectural island evokes images of the past and enriches the viewer's mind, stimulating new explorations and inspiring visionary imagination. The city of collective memory exists; it could be any city.

The city of collective memory, however, is still to be realized; it exists only in gardens built as cities, where memory is brought back to a creative idea, conceived and executed by Schinkel, Lenné, and their contemporaries. Glienicke seems to contain the essence of Schinkel's utopian vision of the humanist city, which is reflected in the reality of his plan for the center of Berlin" (Ungers, 1979, 5).

Thus, Trier, Cologne, and Berlin represent for Ungers diachronic and diatopic stages of an ongoing investigation into the architecture of the city and its relationship with history. According to the hypotheses formulated here, it is not intended to reduce all of Ungers' research

and design experimentation on the city to these three cities, a methodological error given the vast and varied system of cultural references that informs the author's work. Trier, Cologne, and Berlin are rather considered paradigmatic of the work of reading and interpreting urban space in relation to history, outlining the key elements of the constellation of references that inform the author's urban investigations.

What emerges from this synthetic diachronic reading of Ungers' research is the persistence and consistency of his work on specific themes, related to the deep meaning of the architecture of the city.

In relation to the general picture just described, this contribution proposes a reflection on the specific theme of the investigations and experiments conducted by Ungers between the 1960s and 1970s on the city of Berlin, seen as "an open book of events that represent ideas and thoughts, decisions and coincidences, realities and disasters. It is not a uniform grade but a vivid ensemble of pieces and fragments, types and countertypes, a juxtaposition of contradictions, a process more dialectical than linear" (Ungers, 1979, 8). Berlin is thus seen as a research field for radical urban forms and significant contemporary relevance.

In particular, the construction of the general context has required the defining of a *state of the art* on the subject in conjunction with a comparison with some of the research that, in recent decades, have dealt with the theme of the urban vision for Berlin in OMU's work.

The research defines, in the third part, *Berlin as a testing ground for urban concepts*, the development of a dynamics of archipelago city theory. These issues are developed through both the presentation of selected project experiences by Ungers in Berlin, *Berlin's projects*, and in the *Concluding notes* in which we try to trace the actuality of the urban visions discussed.

## LITERATURE REVIEW

A draft of the Green Archipelago was first typewritten by Rem Koolhaas, Peter Riemann, Hans Kollhoff, and Artur Ovaska in 1977, and was later self-published in a small German booklet produced by Ungers' wife, Liselotte. The following year, *Lotus International* published a monographic issue<sup>2</sup> on the theme of the urban block, presenting Ungers' research to an international audience and sparking a lively debate on the city block as a tool for the composition of public and private urban spaces. In 2013, 36 years after the initial publication, Florian Hertweck and Sébastien Marot released a critical edition of the archipelago city in *The City in the City: Berlin, A Green Archipelago* (Hertweck, Marot, 2013), a critical analysis with interviews and facsimiles that renewed attention on urban theory. That same year, Pier Vittorio Aureli published *The Possibility of an Absolute Architecture* (Aureli, 2011), offering in-depth analyses on the metaphor of the city as an archipelago. Marot noted the emergence of the "urban archipelago" or "archipelago city" in architectural discourse over the past two decades (Marot, 2013, 6), while in Berlin, two exhibitions in 2012 were dedicated to the theme of the archipelago: Isa Melsheimer's "A Green Archipelago"<sup>3</sup> and Arno Brandhuber's "Im Archipel"<sup>4</sup>. In 2016, the contribution "Oswald Mathias Ungers' Berlin" (Trentin, 2016) and later in 2022 "Oswald Mathias Ungers - Berlin Speculations" (Trentin, 2022) highlighted the relationship between the author, the city of Berlin, and the archipelago city concept.

The recent revival of interest in *The City within the City: Berlin as a Green Archipelago*, briefly outlined, provides an opportunity to revisit a particularly fertile case in the debate on architecture and the city, offering important insights when applied to contemporary urban conditions, demonstrating how Ungers' research on Berlin, profoundly abstract and at the time provocative and radical, remains highly relevant today.



## BERLIN AS A TESTING GROUND FOR URBAN CONCEPTS

In 1977, when Ungers organized the Sommer Akademie of Architecture in Berlin with Koolhaas, Riemann, Kollhoff, and Ovaska, the city was still devastated by the bombings of World War II and was divided in two by the Wall. Students from Cornell University were invited to work for two months on an experimental project to outline a possible reconstruction for West Berlin and a vision for the city's development. The students and faculty developed eleven theses

exploring two different but highly interconnected themes: The Urban Villa and Die Stadt in der Stadt. The research work culminated in two separate publications: *The Urban Villa. A Multifamily Dwelling Type*<sup>5</sup> (Fig.1) e *Die Stadt in der Stadt. Berlin das grüne Stadtarchipel. Ein Stadträumliches Planungskonzept für die zukünftige Entwicklung Berlins*.

As always in Ungers' research activity, the study of reality is not merely preparatory to the design but is an integral part of the design process, as demonstrated by the experiences in Trier and Cologne. The Sommer Akademie in Berlin is a testament to this.

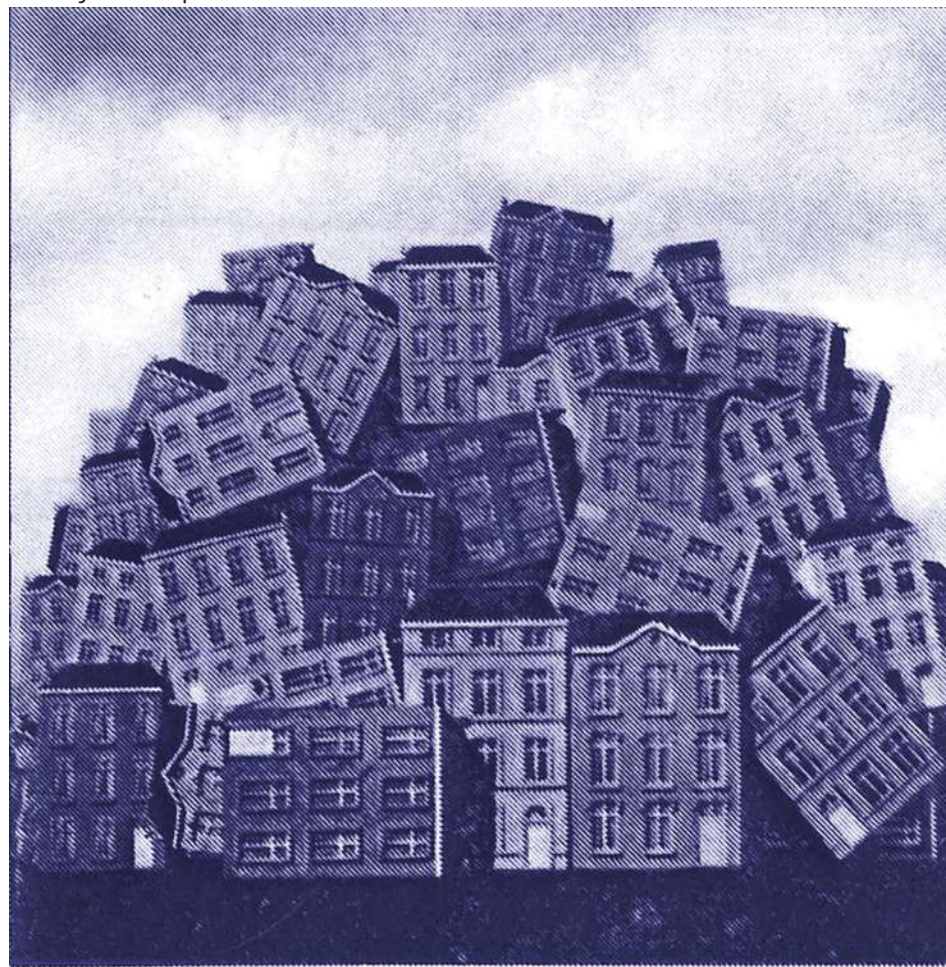

## THE URBAN VILLA

Fig.1 – Front page of Oswald Mathias Ungers, *The Urban Villa. A Multifamily Dwelling Type* (Oswald Mathias Ungers, The architecture of the collective memory. In: Ungers, Oswald Mathias et al. *The Urban garden: student projects for the Südliche Friedrichstadt Berlin*. Köln: Studio Press for Architecture, 1978).

Ungers, his collaborators, and the students deconstruct Berlin. They metaphorically break it into pieces. And from each piece, they develop specific thematic analyses, according to the method of observing the existing urban context, examined in its current state and in relation to the city's history, identifying permanent cultural traits that become elements for the design of urban artefacts. The analysis is developed through a thematic rather than a geographical structure: Berlin is always viewed in its urban scale, as a whole, and is not studied in separate zones. The theses through which Ungers and his group develop the research are monographic with respect to the theme and contribute complementarily to the understanding and design of the city.<sup>6</sup>

The structure of the research is rigid and highly concise. Each thesis is presented as a chapter of a single book: it begins with a brief, objective description of the theme characterizing the specific thesis, followed by a commentary on the issue at hand that explains the outcome of the study. It concludes with final notes in which the research's stance on the given topic is proposed, laying the groundwork for the proposed urban strategy. The textual part is complemented by the research's iconographic section, which, in an equally concise manner, supports the content with diagrams, schemes, and comparisons.

The first part of the research predominantly offers an analytical view of the current state of Berlin. In the first four theses, Ungers develops some considerations on the population size, predicting a decline in the number of inhabitants in the 1980s, and on their distribution across the urban landscape. As people moved towards the peripheral areas, this flow led to a depopulation of the central zones. Drawing on the example of other cities, including Trier, the research argues that the quality of life is not directly proportional to the size of the city, concluding that the optimal size of

a city is around 250,000 inhabitants. The analysis of this data leads the research to critique the planning theories implemented during those years, particularly in relation to urban renewal policies<sup>7</sup> (Eggeling, Ungers, 1965). Ungers writes: "The opinion that prevails today, whereby the historic parts of the city can be preserved and saved only through additional and supplementary construction, stems from erroneous assumptions and is therefore illusory. [...] The realization of the idea of "urban repair", which, if wrongly interpreted, may paradoxically lead, in practice, to the destruction of the city, implies an inevitable thrust toward an increase in buildings, homes, shops, social services, and so on. [...] In Berlin, the theory of urban repair, in the sense of a historic reconstruction, would be particularly detrimental, since the inexorable depopulation process would only be camouflaged and all action taken to improve reality would be pointlessly deferred, to the consequent disadvantage of the city" (Ungers, Koolhaas, Riemann, Kollhoff, Ovaska, 1977, 83). These short-term predictions and the general cultural framework outlined by the research become the premise for every design consideration developed in the second part of the study.

The second part of the research presents the idea of the city within the city as a green archipelago: "The idea of the city in the city is the basic concept for a future urbanistic model of Berlin. It is substantiated in the image of Berlin as a city-archipelago. The urban islands have an identity in keeping with their history, social structure, and environmental characteristics. The city as a whole is formed by the federation of all these urban entities with different structures, developed in a deliberately antithetic manner. A decisive criterion for the selection of these islands ought to be the degree of clarity and legibility of their underlying ideas and concepts" (Ungers, Koolhaas, Riemann, Kollhoff, Ovaska, 1977, 86). The proposal for Berlin intentionally embraces the fragmentation of urban layouts and forms, impersonal architecture, and the

fluidity of the program. Blocks, understood not only as buildings but also as miniature cities, within a green archipelago. The character of the urban enclaves represents their history, social fabric, and physical environment. The city consists of a network of these unique communities, each featuring distinctive architecture deliberately designed to contrast with one another. "The urban concept of the city in the city, pluralistic in this respect, is the antithesis of current planning theory, which stems from a definition of the city as a single whole. It corresponds to the contemporary structure of society, which develops more and more as a society of individuals with different demands, desires and conceptions. The concept also involves an individualization of the city, the issue of citizens identifying with the city is also addressed. While an anonymous city composed along a unifying principle provokes a loss of identity and a loss of personality, the city dweller in an open system may choose the identity-space that corresponds to his desires and expectations" (Ungers, Koolhaas, Riemann, Kollhoff, Ovaska, 1977, 86).

Thus, Ungers' urban vision for Berlin, like Schwartz's for Cologne, is based on the interpretation of history and urban morphology. Berlin is understood as an aggregation of neighborhood-islands that must be recognized and connected to each other, not through homology but through contrast and antithesis. Berlin, in fact, displays areas that are distinguished by their character, as well as their morphological and social structure: "Südliche Friedrichstadt, the Görlitz station, the Schlosstrasse, Siemensstadt, Spandau, and the area known as "the city", but also Märkische Viertel, the Gropiusstadt, and such typical housing developments (Siedlungen) as the Tempelhofer Feld, the Hufeisensiedlung, Onkel Tom's Hütte, but also the cultural island of Kemperplatz, which offers a replica of the historic Museuminsel. The zones just mentioned represent extremely different structures in context and form; they contain not

only buildings in blocks but also single, radial, linear, and reticular urban layouts, open and closed systems, regular and irregular street networks, while also having different graphic, spatial, functional, and social characteristics" (Ungers, Koolhaas, Riemann, Kollhoff, Ovaska, 1977, 88). Identified and selected as islands, Ungers' urban vision organizes the various parts by applying a principle of higher order - a regulatory grid that separates and connects the different components. Berlin is described as a collection of island-isolates, a collection of formally distinct elements, small cities capable of existing autonomously within an urban context devoid of intrinsic value, separated by green areas that simultaneously divide and link, distinguish and diversify.

Proposing an urban strategy for Berlin in the 1970s necessitated a reflection on the theme of reconstruction<sup>8</sup>. Just a year before the Sommer Akademie in Berlin, Ungers had the opportunity to engage with the theme of reconstruction through his vision of the city as autonomous fragments in the competition project for the Schloßpark plan in Braunschweig (1976). This project continues the morphological research at an urban scale conducted by Ungers during the 1970s, particularly focused on Trier. The city of Braunschweig, characterized by a historic urban core densely built with a network of emerging architectures, bordered and surrounded by an urban fringe with a more sparse and point-like morphological fabric, features an urban structure characterized by the coexistence of different and autonomous elements. In the Schloßpark project, which covers a large portion of the city to the southeast, Ungers addresses the history of the city and the park. He studies its current layout as well as its transformations over the centuries to develop a series of design proposals related to the park area and its adjacent places, which could indicate new directions for development and growth in this part of the city. Ungers' experience in Braunschweig, although it is a city not as evidently marked by history



as Trier, and not suffering from the severe war damage as Berlin, on one hand confirms the author's interest in the history of urban structure and, on the other hand, demonstrates Ungers' tendency to interpret historical elements in an autonomous and independent project.

The theme of reconstruction during those years focused architectural debate on methods of intervention in war-damaged centers. As previously noted, one of the most important lessons Ungers draws from the study of Trier, its configuration and its architecture, is the concept of modification. For Ungers, every architecture is based on the idea of modification, according to which the existing is to be considered as material to be unveiled and utilized. This approach to architectural design involves not so much the need to typologically reconstruct the city or to undertake interventions legitimized by the context and history of the place, as seen in the reconstruction projects for the Römerberg in Frankfurt, but rather the necessity of establishing a strong connection between the place and its interpretation and transformation - essentially, performing a hermeneutic operation on the place.

Ungers' idea is to rewrite the city in order to identify a new order, a new form of identity for the place. As Fritz Neumeyer has noted, "Just as art, according to Nietzsche's maxim, re-creates reality by making choices, accentuations, and estrangements, so Ungers re-theorizes the 'city' as a constructed reality: not to sublimate the pre-existing into an idyll of accidentality, but to anticipate, by positing a thesis, that connection between reality and meaning which projects an idea into the place, thus providing it with a new 'awareness,' a new form of identity" (Neumeyer, 1991, 18).

The archipelago city does not propose a single strategy for reconstruction but rather a selection of elements to be preserved: on one hand, certain areas will be enhanced, while on the other,

there will be a complete removal of what has lost all significance: "Here the structures, by now valueless, ought to be allowed to gradually retransform into natural zones and pastures, without any rebuilding. This concerns in particular the areas of Kemperplatz, the stations of Görlitz and Potsdam, and, at a later stage, the Tempelhofer airport. Hence, the urban islands would be divided from each other by strips of nature and green, thus designing the framework of the city as a green archipelago" (Ungers, Koolhaas, Riemann, Kollhoff, Ovaska, 1977, 90). The tenth thesis is indeed entirely dedicated to the theme of reconstruction, defining standards and objectives according to the principle of transformation, as investigated through the studies of the city of Trier developed precisely during the 1970s (D'Alessandro, 2015).

In the tenth thesis of the Archipelago City, Ungers himself writes: "The issue in question is no longer the design of a completely new environment, but rather the rebuilding of what already exists. The task at hand is not the invention of a new urban system, but the improvement of what is already there, not the discovery of a new order, but the rediscovery of proven principles, not the construction of new cities, but the restructuring of the old ones - this is the real problem for the future. What is needed is not a new Utopia, but rather a blueprint for a better reality. And this is something that applies not only to Berlin but also to the majority of other large cities. Berlin might, however, prompt initiatives that go beyond its particular problematic and thus assume an exemplary and universal character" (Ungers, Koolhaas, Riemann, Kollhoff, Ovaska, 1977, 96).

## BERLIN PROJECTS

By tracing the development of Ungers' vision for the city through his various proposals and studies from the 1960s and 1970s, one can discern the radical concept of Berlin as a Green Archipelago. Considering Ungers' innovative

urban design projects and his educational research on Berlin, this collection can be viewed as a single, continuous and cohesive project culminating in the idea of Berlin as a Green Archipelago.

In the 1960s he develops a series of urban projects: housing proposals for Cologne Neue Stadt (1961-1964), Cologne Grünzug Süd (1962-1965), Berlin Märkisches Viertel (1962-1967) and Berlin 1995 (1968). The experimentation developed in these projects testifies to a critique of the late modernist urban that design the city through the generic application of given building standards and functions (Fig.2).

The debate on new urban visions, contrasting with the plans of late modernist urbanism, once again sees Berlin as a paradigmatic testing ground. In 1958, an important international competition was announced to define the urban plan, aimed at conceptualizing the reconstruction of the city center destroyed in World War II.

The Hauptstadt Berlin 1958 competition received projects from Alison and Peter Smithson, Hans Scharoun, Le Corbusier and others. For Le Corbusier, this was also a rare chance to advance ideas about functional city planning, initially developed forty years earlier for the center of Paris (Cohen, 2013). The Berlin competition project was created almost simultaneously with the crises and eventual dissolution of CIAM in the 1950s, leading to the rise of Team 10. At that time, the design methods associated with CIAM were being scrutinized. Additionally, Le Corbusier's universalist approach to urbanism, as outlined in his Athens Charter, was starting to be questioned by CIAM's younger generation. While many proposals<sup>9</sup>, including Le Corbusier's, were connected to CIAM's principles, Hans Scharoun's and Alison and Peter Smithson's proposals represented alternative approaches based on new concepts associated with the emerging generation (Mumford, 2002).

A few years after this event, Ungers developed three projects

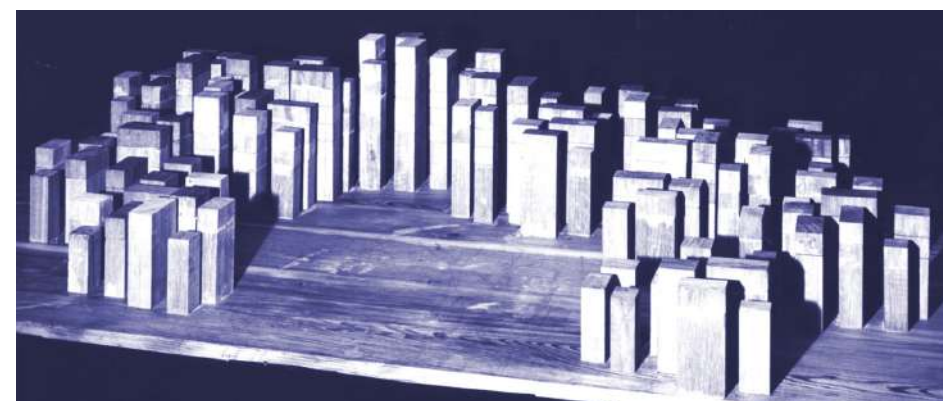

Fig.2 - Model photo of the Neue Stadt in Cologne (1963) (Oswald Mathias Ungers. Zum Projekt «Neue Stadt» in Köln / About the Project «New Town» in Cologne. In: *Das Werk: Architektur und Kunst* 50. 1963, issue 7, p. 284).



Fig.3 - General plan and photo from the street and the inner courtyard (1963) (Oswald Mathias Ungers. O. M. Ungers. Sozialer Wohnungsbau 1953-1966. In: *Baumeister*. 1967, issue 64, pp. 566- 567).

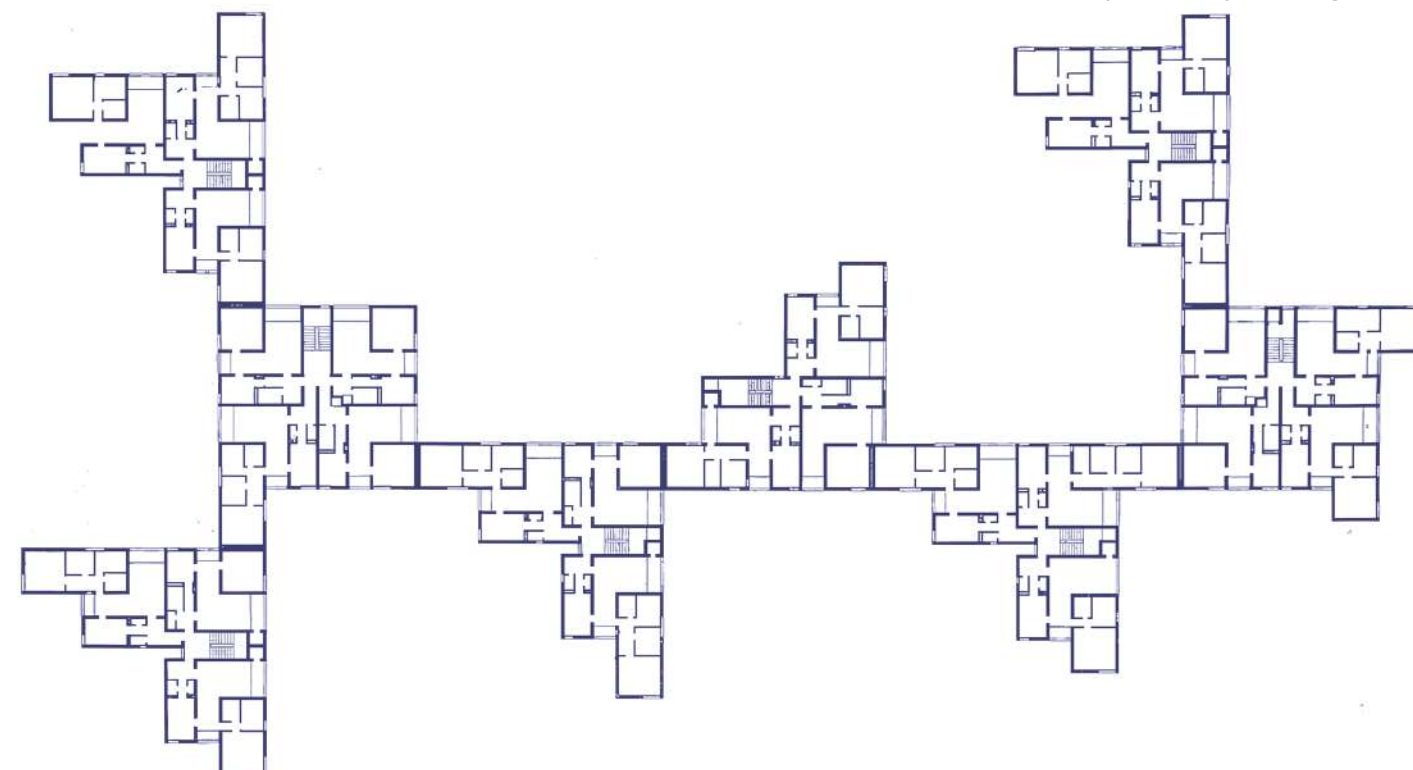

Fig.4 - Oswald Mathias Ungers, Neue Stadt, Cologne (1961-64), ground floor, © Martina D'Alessandro, 2023.

that, despite differing in context and scale, experiment with the idea of the city within the city in practice, designing new housing complexes not as a generic extension of the city but as evocative of an idea of the city (Aureli, 2011). With these experiences, he begins the design confrontation with the theme of the form of living in relation to the form of the city.<sup>10</sup>

In the residential projects for Cologne and Berlin, Ungers works on architectural mass, defining a monumental composition of volumes that gives form and meaning to the empty space, i.e., public space. Instead of designing an urban layout with slabs and towers scattered randomly through green spaces without any clear shape, he creates well-defined city elements (Fig.3).

The Neue Stadt project is envisioned as a collection of residential towers of varying heights, but arranged to form a unified architectural structure: these towers are organized as vertical volumes that enhance the spatial and formal design of the whole complex (Fig.4). He used a similar method for the Märkisches Viertel complex in Berlin, positioning the residential towers around a series of open courtyards (Fig.5-



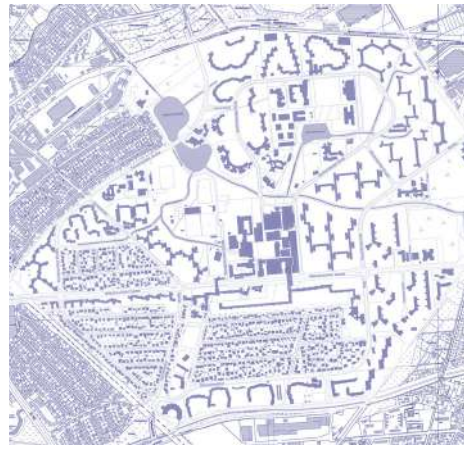

Fig.5 - Oswald Mathias Ungers, Märkisches Viertel, Berlin (1962-67), general plan, © Martina D'Alessandro, 2023.



Fig.6 - Oswald Mathias Ungers, Märkisches Viertel, Berlin (1962-67), © Google Heart, 2024.

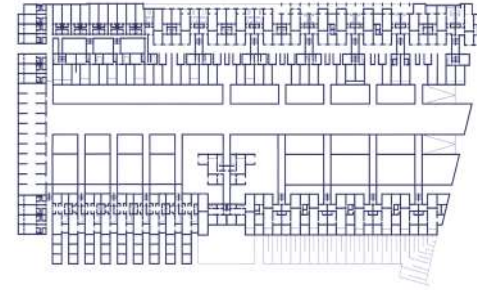
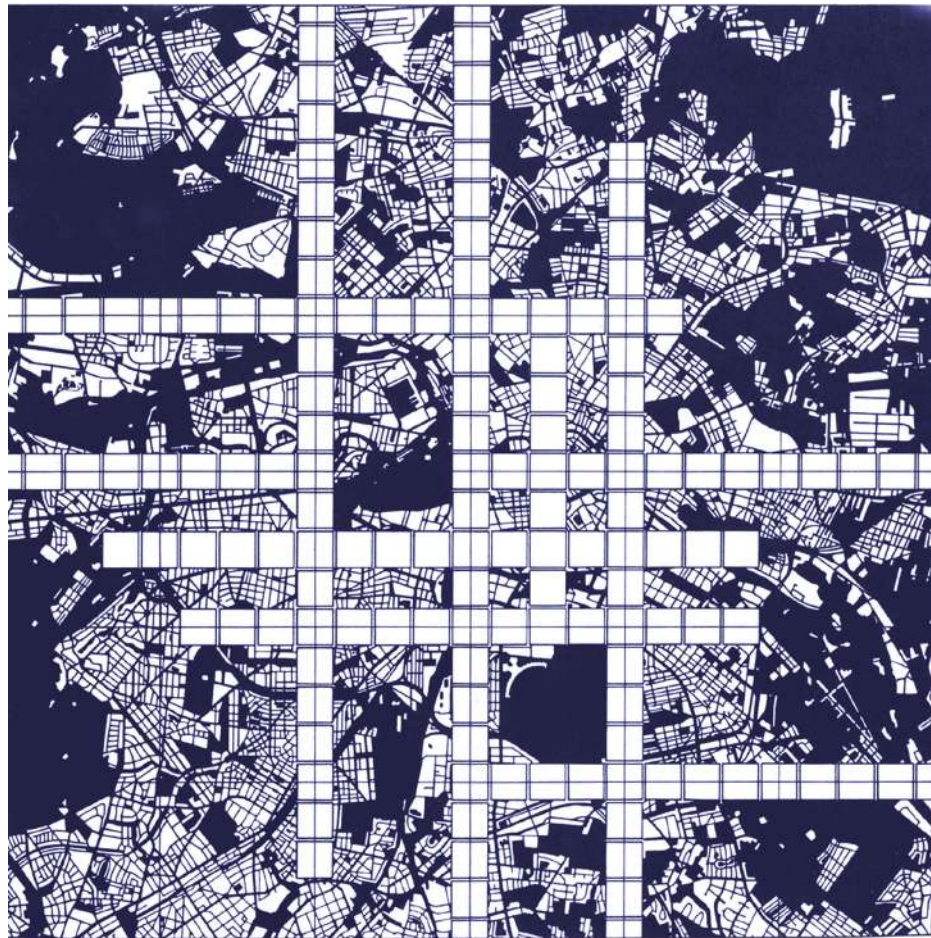

Fig.7 - Oswald Mathias Ungers, Grünzug Süd, Cologne (1962-1965), ground floor, © Martina D'Alessandro, 2023.



# Berlin 1995

Fig.8 - Front page of Oswald Mathias Ungers, Berlin 1995. (Oswald Mathias Ungers, Berlin 1995, planungsmodelle für eine fünfmillionenstadt im übergang zu den siebziger Jahren, Berlin, Veröffentlichungen zur Architektur, 25, 1969).

6). For the Grünzug Süd project, Ungers envisioned a gradual transformation of the site, driven by a morphological analysis and interpretations: he evolves spaces and buildings of the existing city into a linear composition of different architectural events. The linear composition of Grünzug Süd defines the city as a dialectical composition of artifacts and considers the street as an element with strong identity and autonomy (Fig.7). In accordance with the findings of Aureli's research, the project of Grünzug Süd complex, and some years later, the theoretical project Berlin 1995 (Fig.8), represent an important step in the development of radical reflections on the city. "One can argue that such an approach to the city - an approach inspired by Ungers's Grünzug Süd project - became the conceptual basis for Koolhaas's *Delirious New York*, which uses the most critical urban conditions as the basis for a city project. In following this link between Ungers and the early work of Koolhaas and Zenghelis, we can see the fundamental development of Ungers's city-within-the-city concept as the germ of Koolhaas and Zenghelis's *Exodus*, or the *Voluntary Prisoners of Architecture* (1972). [...] *Exodus* consists of two parallel walls cutting through London and dividing it into eight enclosed parts. Both the housing complex of Grünzug Süd and the Berlin Wall also cut through an existing city, encompassing and radicalizing the different city conditions. *Exodus* was not

simply a line, like Superstudio's Continuous Monument, or the repetition of an identical module, like Ivan Leonidov's scheme for Magnitogorsk (although both projects were surely inspirations for *Exodus*); it was a linear composition made of radically different city parts" (Aureli, 2011, 196-197). A similar formal and programmatic radicality is present in the proposals presented by Ungers' students in his 1968 course at the TU, Berlin 1995 (Ungers, 1968), in which a rational horizontal urban grid is superimposed on war-destroyed Berlin.

The 1970s are marked by significant urban projects that emphasize the current urban conditions with the goal of transforming urban fragmentation into a contrasting composition of forms. In his designs for Berlin Tiergarten Viertel (1973) and Berlin Lichterfelde (1973), Ungers does not create a single comprehensive plan but instead develops a series of independent architectural elements tailored to local contexts.

In Tiergarten Viertel, these elements consist of superblocks loosely arranged along the Landwehrkanal, while in Lichterfelde, they are organized into strips positioned perpendicular to the main road. Lichterfelde (Fig.9), along with Tiergarten Viertel, represents Ungers' most radical approach toward the concept of the city, which he would later summarize in his idea of Berlin as a Green Archipelago. This series of projects, both completed and unbuilt, can be viewed as a unified effort culminating in the concept of Berlin as a Green Archipelago. This perspective becomes particularly evident when considering Ungers' influential urban design works and his didactic research on Berlin (Aureli, 178, 180), demonstrating for Ungers that theory, necessarily, must be supported and guided by practice (Cepl, 2007 p. 290). Thus, the Berlin Green Archipelago can be seen not only as the final step of a broad and complex research but also, and perhaps most importantly, as the most radical interpretation of urban visions for Berlin.

## CONCLUDING NOTES

Despite *The City in the City: Berlin as a Green Archipelago* never having garnered the same level of attention as other examples of "site-specific manifestos," the "City in the City" has attracted the interest of many architects over the past 40 years. This contribution aims, on one hand, to outline the general features of Ungers' research on the city, both historical and contemporary, within which the reflections on Berlin are situated, highlighting the main factors that influenced the genesis of the idea of the green archipelago city. On the other hand,

the paper revisits the concept of the archipelago city with the belief that it can still serve as a significant tool for constructing new project narratives for today's city.

This document, viewed as a continuous research project that engaged Ungers' attention during the 1960s and 1970s, originated and developed during a historical moment marked by social, political, and cultural tensions and contrasts across Europe. During those years, Ungers was particularly sensitive to the political climate of the 1970s, the New Left, the "German Student Movement," the



Fig.9 - Oswald Mathias Ungers, Lichterfelde, Berlin (1973), general plan, © Martina D'Alessandro, 2023.



Italian "68", and the "French May" in Paris. The climate of opposition and protest generated, within the architectural cultural debate, a series of radical attitudes, which Germano Celant termed Radical Architecture. The issues associated with the radical movement led to avant-garde research, developing project proposals that did not refer to reproducible realities but rather acted as autonomous communicative acts of opposition and protest, often actual manifestos for a new architecture. In this context, the radical nature of Ungers' project for Berlin as a Green Archipelago lies not only in its critique of functionalism and its opposition to the modernist urban culture based on a unitary vision of the city. Rather, it emphasizes the unique nature of the radicalism in his research on Berlin, understood as "rooted in the intrinsic meaning of things," specifically of the urban thing. This interpretation focuses on a way of practicing architecture that is certainly bold and innovative but oriented towards action rather than mere opposition: a concrete vision that intervenes in the fragmented urban structure of the city, interpreted as the true DNA of Berlin. It represents an attitude, a way of viewing the world and choosing to be part of it by following methods that are not dictated by the majority's orientation (politics, institutions, masters, market, consumption, clients).

Such a design trajectory, even after more than 40 years, offers many contemporary insights. The inferred city model generates reflections on the same themes that occupy the critique of today's and tomorrow's cities: the relationship with nature, the concept of a sustainable city, energy conservation, and considerations on density are just a few of these themes. The concept of a city consisting of a series of urban islands, each separated yet linked by a network of parks and green spaces, was not adopted by the city, which chose to pursue a more economically driven approach. Reflecting on the master plan imagined for Berlin, it's easy to see that if the city had evolved

into a collection of "urban islands" encircled by parks and natural landscapes, its residents would likely have enjoyed a higher quality of life, living in harmony with nature and the ecosystem.

The recent and growing interest in sustainable urban regeneration establishes close ties with the vision of the Green Archipelago through planning policies that promote the controlled fragmentation of urban settlements, aiming to create self-sufficient neighborhoods surrounded by green spaces. In this regard, Ungers' thinking, which envisioned the city as an archipelago of distinct residential nuclei, is remarkably prescient of today's strategies for sustainable urban development.

The recent and growing interest in sustainable urban regeneration establishes close ties with the vision of the Green Archipelago through planning policies that promote the controlled fragmentation of urban settlements, aiming to create self-sufficient neighborhoods surrounded by green spaces. In this regard, Ungers' thinking, which envisioned the city as an archipelago of distinct residential nuclei, is remarkably prescient of today's strategies for sustainable urban development.

The project approaches the concept of nature as an integral part of the constructed city, proposing an open-ended strategy for defining the green expanse of the archipelago. According to Aureli, Ungers offered two contrasting visions for these green spaces: one was akin to what we now refer to as "locally-sourced" agriculture, where island inhabitants could cultivate their own food, ensuring their settlement's economic autonomy from larger systems; the other was inspired by Hilberseimer's urban studies in Chicago during the 1940s and 1950s, which suggested radically decentralizing the city into communities set within a green landscape and connected by highways. This dual, contradictory vision of the green sea of the archipelago both stimulated imagination and challenged

contemporary ideas of ecological urbanism by demonstrating how the concept of "green" could support opposing scenarios of collective self-reliance and complete individualism. Ungers perceived green or the void, as something inherently ambiguous, capable of accommodating both extreme situations: a retreat from urban life while simultaneously embracing it. This approach established a contrast between the island and the sea, representing a dialogue between clearly defined boundaries and an ever-changing, unstable environment (Aureli, 2011, 225-226).

Ungers' design approach, which integrates theory and practice, thus demonstrates the ability to address contemporary problems. Today's global cities are increasingly fragmented, characterized by social polarization, spatial discontinuity, and economic and social inequalities. Building the city from autonomous elements should not necessarily be seen as a limitation but can become a strategy to preserve the identity of places and promote urban diversity. At a time when cities are forced to confront a range of challenges related to climate change, sustainability, and increasing densification, the idea of constructing the city not through formless expansions and urban sprawl but via a system of autonomous nodes connected by green spaces offers an innovative perspective.

Berlin as a Green Archipelago continues to offer valuable insights and inspiration for how we conceive of cities and architecture today. This doesn't imply that we should view this research as an outdated artifact of architectural theory. Instead, it prompts us to engage with current realities, evaluating its applicability to contemporary urban settings, modern society, and our current ways of living. According to Marot in his recent publication, the Green Archipelago could provide a revitalizing perspective, offering a counter to the detrimental impacts of prevailing urban expansion models that still influence our cities (Marot, Hertweck, 2013).

## BIBLIOGRAPHY

AURELI, Pier Vittorio. *The possibility of an absolute architecture*, Cambridge: The MIT Press, 2011.

BASSO PERESSUT, Luca. Il Kulturschirn di Francoforte. In: *Domus*. 1986, issue 675, pp. 1-3.

BURGARD, Roland. Der Fall: Römerberg in Frankfurt: Rekonstruktion und Postmoderne. In: *Baumeister*. 1985, issue 82, n° 1, pp. 34-41.

BURGARD, Roland. The Dom-Römerberg quartier: revitalization of the city centre for cultural purposes. In: *International Journal of Museum Management and Curatorship*. 1986, issue 5, n° 1, pp. 14-18.

CEPL, Jasper. *Oswald Mathias Ungers. Eine intellektuelle Biographie*, Köln: Walther König, 2007.

COHEN, Jean-Louis. *Le Corbusier: An Atlas of Modern Landscapes*. New York: Thames & Hudson, 2013.

D'ALESSANDRO, Martina. *Oswald Mathias Ungers a Treviri*. Due musei. Bologna: Bononia University Press, 2015.

D'ALESSANDRO, Martina. Hacer la ciudad / Making the city. In: Hernández León, Juan Miguel, Calatrava, Juan (eds). *Arquitectura Y Paisaje, Transferencias históricas retos contemporáneos*. Vol. 1, Madrid: Abada Editores. 2022, pp. 191-204.

EGGELING, Fritz, Oswald Mathias UNGERS, (eds). *Symposium 1964*. Berlin: Veröffentlichung der Fakultät Architektur, 1965.

KOOLHAAS, Rem. *Delirious New York. A Retroactive Manifesto for Manhattan*. New York: Oxford University Press, 1978.

KROHN, Carsten. *Das Ungebaute Berlin: Stadtkonzepte im 20. Jahrhundert*. Berlin: DOM publisher, 2010.

MAROT, Sebastien, Florian HERTWECK (eds). *The City in the City: Berlin, A Green Archipelago*. Zürich: Lars Müller, 2013.

MUMFORD, Eric. *The CIAM discourse on urbanism, 1928-1960*. Cambridge, Massachusetts: MIT Press, 2002.

NEUMEYER, Fritz. L'enigma dell'architettura. Un tutto a sé stante e un'unità di particolari. In: NEUMEYER, Fritz, Oswald Mathias UNGERS (eds). *Oswald Mathias Ungers: Architetture 1951-1990*. Milano: Electa, 1991, pp. 7-23.

PURINI, Franco. *Comporre l'architettura*. Roma-Bari: Edizioni Laterza, 2000.

SCHWARZ, Rudolf. Ricostruire città distrutte. In: PEHNT, Wolfgang, Hilde STROHL. *Rudolf Schwarz 1897-1961*, Milano: Electa, 2000.

STADT KÖLN (eds). *Das neue Köln. Ein Vorentwurf*. Köln: Verlag Bachem, 1950.

STELLA, Franco. Una galleria d'arte fra il duomo e il municipio: il Kulturschirn al Römerberg, Francoforte, di Bangert, Jansen, Scholz e Schultes. In: *Lotus international*. 1987, issue 55, pp. 54-67.

TRENTIN, Annalisa. La Berlino di Oswald

Mathias Ungers. In: *La Cultura y la Ciudad*, Granada: Editorial Universidad de Granada, 2016, pp. 1063-1070.

TRENTIN, Annalisa. Oswald Mathias Ungers – Speculazioni berlinesi. In: MALACARNE, Gino, Anna FABRIS (eds). *La ricostruzione della città europea*. Firenze: Aion, 2022, pp. 127-132.

UNGERS, Oswald Mathias. *Schlosspark Braunschweig*, typewritten notebook containing texts commenting on the project and graphical and diagrammatic drawings, kept at Ungers Archiv für Architekturwissenschaft, Cologne.

Ungers, Oswald Mathias. Zum Projekt «Neue Stadt» in Köln/About the Project «New Town» in Cologne. In: *Das Werk: Architektur und Kunst* 50. 1963, issue 7, pp. 281-284.

Ungers, Oswald Mathias. O. M. Ungers. Sozialer Wohnungsbau 1953-1966. In: *Baumeister*. 1967, issue 64, pp. 556- 572.

UNGERS, Oswald Mathias. *Berlin 1995. Planungsmodelle für eine fünfmillionenstadt im übergang zu den siebziger Jahren*. Berlin: Veröffentlichungen zur Architektur, 25, 1969.

UNGERS, Oswald Mathias. Project for Braunschweig Castel Park. In: *Lotus international*. 1977, issue 14, pp. 100-110.

UNGERS, Oswald Mathias. The architecture of the collective memory. In: UNGERS, Oswald Mathias et al. *The Urban garden: student projects for the Südliche Friedrichstadt Berlin*. Köln: Studio Press for Architecture, 1978.

UNGERS, Oswald Mathias. Le città nella città. In: *Lotus International*. 1978, issue 19, pp 82-97.

UNGERS, Oswald Mathias. Architecture of the Collective Memory. The Infinite Catalogue of Urban Forms. In: *Lotus International*. 1979, issue 24, pp. 4-11.

UNGERS, Oswald Mathias. Die Neubauten zwischen Dom und Römer. Eine Halle als Stadtzentrum (Adolfo Natalini) – Eine Würdigung. In: Klotz, Heirich (eds). *Jahrbuch für Architektur 1984. Das Neue Frankfurt 1*. Braunschweig-Wiesbaden: Friedrich Vieweg & Sohn, 1984, p. 42.

UNGERS, Oswald Mathias, Hans KOLLHOFF, Artur OVASKA. *The Urban Villa. A Multifamily Dwelling Type*. Köln-New York: Studioverlag für Architektur Liselotte Ungers, 1977.

UNGERS, Oswald Mathias, Rem KOOLHAAS, Peter RIEMANN, Hans KOLLHOFF, Arthur OVASKA. *Die Stadt in der Stadt: Berlin, das Grüne Stadtarchipel: Ein stadträumliches Planungskonzept für die zukünftige Entwicklung Berlins*. Köln: Studioverlag für Architektur Liselotte Ungers, 1977.

## NOTES

1. UNGERS, Oswald Mathias, Rem KOOLHAAS, Peter RIEMANN, Hans KOLLHOFF, Artur OVASKA. *Die Stadt in der Stadt: Berlin, das Grüne Stadtarchipel: Ein stadträumliches Planungskonzept für die zukünftige Entwicklung Berlins*. Köln: Studioverlag für Architektur Liselotte Ungers, 1977.

2. UNGERS, Oswald Mathias. Le città nella città. In: *Lotus International*. 1978, issue 19, pp 82-97.

3. Isa Melsheimer, "A Green Archipelago" Esther Schipper Gallery, Berlin, June 2 - August 28, 2012. With "A Green Archipelago", the artist clearly alludes to Ungers' 1977 study Berlin as Green Archipelago, picking up the associated concept of urban islands and implementing it in terms of formal aesthetics. With "A Green Archipelago", Isa Melsheimer presents a scenario that filters out and juxtaposes historic architectural structures and even intervenes with the architecture. Possibilities of autonomy and appropriation are formulated, animating the scenario.

4. Arno Brandlhuber, "Im Archipel", Berlin, October 2012. "Im Archipel" was an exhibition built upon the manifesto for a shrinking city *The City in the City - Berlin: A Green Archipelago* by Oswald Mathias Ungers. The book served as a historical foil for a dystopic explanatory model of Berlin that used to be characterized by urban heterogeneity - but has been experiencing a reorganization and a deliberate redistribution of social life since the early 2000s.

5. UNGERS, Oswald Mathias. The architecture of the collective memory. In: UNGERS, Oswald Mathias et al. *The Urban garden: student projects for the Südliche Friedrichstadt Berlin*. Köln: Studio Press for Architecture, 1978.

6. The themes through which Berlin is investigated are: 1. Berlin's population drop. 2. Criticism of current design theories. 3. The problem of the population drop. 4. The differentiated urban structure. 5. The idea of the city in the city. 6. Establishment of the area of city-island. 7. The green archipelago. 8. The urban villa as a form of residential building. 9. Transformation of the city in the course of history. 10. Standards definition of objectives for the future. 11. Scheduled project times.

7. Reflections on urban renewal policies are not new but have a precedent in the seminar organized by Ungers at the TU Berlin in 1964 on the topic of the redevelopment of the historic center of Berlin-Spandau.

8. The theory of the archipelago city represents a significant contribution to the content of the IBA and the definition of its program for new architectural developments.

9. The competition garnered significant international attention, receiving 86 submissions from cities beyond Berlin, such as London, Vienna, Paris, and Florence. Notable submissions included: Spengelin, Eggelin & Pempelfort, who won the contest; Hans Scharoun, who took second place; Alison and Peter Smithson, along with Peter Sigmund, who were awarded third place; as well as Jorn Utzon, Sven Markelius, and Luigi Piccinato, among others.

10. The 1950s are indeed characterized by intense design activity related to residential themes, without delving into the relationship between home, city, and public space. The projects focus primarily on single-family homes and small residential blocks, mainly in Cologne.



# RADICAL SCALES



# Restoring porosity in Greater Cairo through architectures without architects

Case study of the “Koka” pigeon tower in  
Garbage City

porosità  
architettura senza architetti  
Cairo  
rizoma  
torre per piccioni  
**porosity**  
**architecture without architects**  
**Cairo**  
**rhizome**  
**pigeon tower**

**Carandente, Alberta<sup>1</sup>**

<sup>1</sup> German University in Cairo, Product Design, Cairo, Egypt.  
<https://orcid.org/0009-0008-9828-596X>  
carandentealberta@gmail.com

Citation: Carandente, A. (2024). “Restoring porosity in Greater Cairo through architectures without architects”, UOU scientific journal #08, 68-77.

ISSN: 2697-1518. <https://doi.org/10.14198/UOU.2024.8.08>  
This document is under a Creative Commons Attribution 4.0 International license (CC BY 4.0)

Article Received: 15/09/2024  
Received in revised form: 02/10/2024  
Accepted: 09/11/2024



L'etimologia della parola "radicale" (dal tardo latino *radicalis*, "radice") suggerisce un legame con azioni spontanee e rivoluzionarie. Greater Cairo, un luogo di conflitti, mostra come gli impulsi dal basso possano sfidare i nuovi insediamenti urbani e ripristinare la porosità della città. New Cairo è progettata con micro-unità chiuse, focalizzate sulla sicurezza, mentre il vecchio Cairo resiste con la sua architettura spontanea. Analizzando i colombari, torri leggere e giocose, si comprende il loro ruolo nel favorire una città porosa, con strutture adattive che rinforzano i legami sociali. La nuova città può imparare da quella vecchia, migliorando la permeabilità degli spazi e favorendo l'interazione tra diverse classi sociali. Le non-architetture effimere, come rizomi sui tetti dei quartieri poveri, creano reti basate su ideali condivisi e accordi sociali non scritti, introducendo il gioco come elemento fondamentale per il pensiero evolutivo e la vita sociale. Il caso studio rappresenta una non-architettura auto-costruita, dedicata ai piccioni, che riabilita il valore della comunità e si inserisce nello skyline della città. Questi elementi definiscono una traiettoria futura per ripristinare la porosità a Greater Cairo, dalla scala urbana a quella residenziale, partendo dalla torre per piccioni "Koka".

The word "radical" comes from the Latin *radicalis*, meaning "root," which connects to spontaneous, revolutionary actions. Greater Cairo, Egypt, a place of tension and opposition, reveals how bottom-up impulses, without hierarchies, can challenge new urban settlements and restore porosity to the city. The new Cairo is designed with enclosed micro-units focused on extreme security, while Old Cairo resists abandonment with its spontaneous architecture. Through the dovecotes - slender, playful towers - the study highlights their role in fostering a porous urban space, showing both practical utility and their social value in enhancing communal connections. The new city can learn from the old by improving spatial permeability and encouraging social fluidity, promoting interaction across different classes. These non-architectural, ephemeral structures, like rhizomes on rooftops in poorer neighborhoods, create networks based on shared ideals. By reintroducing play as a key element, they contribute to societal and human growth. Ultimately, this case study represents a self-built, playful non-architecture that revitalizes community ties and occupies the city's skyline, offering a vision for restoring porosity in Greater Cairo.



## INTRODUCTION

The etymology of the word radical, (from late Latin radicalis, der. of radix -icis 'root') suggests a connection to spontaneous, revolutionary and potentially irrational actions. Greater Cairo<sup>1</sup>, Egypt, a place of friction and opposition, with its compounds<sup>2</sup> and simultaneously architecture without architects, shows how impulses from below and without hierarchies, can question the new urban settlements and restore porosity into the city. The new Cairo is being designed to accommodate enclosed micro-units, both in residential and commercial solutions, finding as a primary design expedient, the desire to guarantee extreme security for its inhabitants. Old Cairo, meanwhile, resists abandonment with its spontaneous architectures: through the case study of the dovecotes, slender and playful towers, the analysis leads to understanding their role in fostering a porous urbs<sup>3</sup>, revealing both

their tangible utility, through their adaptive, improvised structures, and their intangible value, in enhancing social and communal connections. Therefore, the new city has the opportunity to learn from the old one and from the actions of its inhabitants, solving a lack of permeability of spaces. This would ensure social and space fluidity, improving spontaneous interactions among people of different classes. These ephemeral non-architectures, like a rhizome<sup>4</sup> spread across the rooftops in the poorest neighbourhood (Fig.1), foster networks based on shared ideals and unwritten social agreements. By reintroducing play as a fundamental element in modern evolutionary thought, they contribute to critical aspects of human life and societal function. In conclusion, the case study represents a non-architecture, self-built, dedicated to a non-human persona (pigeons) with a purely playful function, that rehabilitates the value of the community, through a physical network, occupying the city's skyline, forcefully entering in

the imagination of passers-by. All these elements merge to define a future trajectory to restore porosity in Greater Cairo, from the urban scale to the residential one, starting from the radical case study of the "Koka" pigeon wooden tower.

## METHODOLOGY

As the research is a logically deduced theory, in its introductory phase of development, and based on ungrounded assumption (Glaser and Strauss, 1967), the structure of this study follows a progression from a broader field to a specific case study (Funnel Structure). Therefore, the process maintains a continuous correspondence, allying data collection and examination (Quantitative Methodology), on field interviews and observations (Qualitative Methodology) and the integration of all the methodologies. This mixed approach is based on "Grounded Theory" by Glaser and Strauss (1967), although it is not only data-driven. The aim

to integrate both qualitative and quantitative strategies is to foster a comprehensive and empathetic understanding of the research question at this preliminary stage.

This approach is intended to lead to future comparisons with other neighborhoods in Cairo and additional case studies, facilitating a deeper exploration of their connections within the residential community. Indeed, there is no distinct "Literature Review" chapter, as the investigation does not rely on pre-existing theories, but uses literature - and data - to investigate and support the themes that emerge during the study. Consequently, the analysis explores the case study of the "Koka" Pigeon Tower, to demonstrate, through an on-field visit and informal interviews, the capacity of an ephemeral, non-architecture, to question the urbs, by restoring the porosity in Greater Cairo. This lack of porosity is a theory based on the author's in field observation and direct experience, both of old and New Cairo, supported by a data collection of official governmental strategies, such as Cairo Vision 2050, the UN reports and World Data Bank statistics. The need for porosity is supported by a literature investigation that focuses on the Radical Period (1960s) and by the intangible elements observed mainly in the neighborhood of Downtown Cairo.

The study adopts a funnel structure due to its interdisciplinary nature, the diversity of layers, and the complexity of its objectives. It begins with a holistic overview of Greater Cairo, gradually narrowing down to a specific area: Garbage City<sup>5</sup>, which hosts the case study. The focus then narrows further, to examine the ephemeral case of the pigeon towers and their role in the urban and social fabric of the metropolis. The "Koka" pigeon tower has been documented by the author through field observations and a one-on-one interview (date: 7th September 2024) with Mr.Waseem, the owner of the tower and the building that hosts it. This specific section will have a narrative style and report some of the personal

considerations of the tower's owner.

The conclusion reports objective and empathetic consideration of the research, with the ambition of expanding the case studies not only to Cairo, but also to the other urbs, to investigate further non-architectures that might question the designed settlements, in their lacking of empathy and porosity, to assess whether it is possible to achieve a sustainable balance between formality and informality.

## GREATER CAIRO

Cairo is the most densely populated city of the Middle East (World Bank, 2008), originally developed along the Nile, currently spreading through the desert areas, due to an abnormal and significant expansion, started in 1950 (UNHabitat, 2016), from Nasr City to New Cairo, then the relocation of governmental offices to the New Capital, which now marks the limit of Greater Cairo. During the last decade, the government has implemented a strategy initiated in 2008, to promote a futuristic vision of the city, named Cairo vision 2050 (UN-HABITAT, 2006). The initiative provides incentives for those who could relocate in these new areas; "there are (...) universities, libraries, movie studios, and specialized hospitals and museums, all of the highest international standards" (Sims D., 2012). These satellite cities are now populated by privileged citizens, motivated by the ideal of living in neighborhoods inspired by exotically Americanised models. Simultaneously, those who could not afford such aspirational ideals converted into compounds, established in these areas and started irregular occupations, next to these closed cities, secured by high walls and gates. Therefore, the gap between social classes is even clearer, highlighting the possibility of contributions from the informal settlements, from whom we can discover a porosity ignored in the formal neighborhood: not only the ashwa'iyat, the informal settlements occupied by 60% of the population (Piffero E., PDP, 2009), but also the ephemeral structures of "burj el hamam", the pigeon

house, which still survives and rises above the roofs of poor Cairo's neighborhoods, while the awamats, floating houses on the Nile, have been dismissed (only few still survive) in order to pursue the new governmental plans.

## GARBAGE CITY

*Manshiyat Naser*, known as 'Garbage City' or 'Hay El-Zabbalin', is an urban settlement in Cairo defined by three properties:

The first is **morphological**, given the presence of Mokattam Mountain and the impact it has generated on urban development.

- The second is **employment-related**, as residents support themselves by collecting, sorting and disposing of the majority of the city's rubbish.
- The third, is a defined **religious cult**, in this case, the Coptic one.

Garbage City is developed as "an informal area built on former state land, which spreads out from an initial authorised nucleus."(Fig.1) The "garbage collectors relocated to the area by the government in the 1960s" (Piffero E., PDP, 2009). A city occupied by garbage, dust from the mountains, sand brought by the desert wind, and by the fumes of incinerators: during the on field observation (date: 7th of September 2024), the informal interviews collected through the visit, enhance an understanding of how the desire is to invest earnings in buying property outside the city, to ensure a better life for children. In spite of this, many declare themselves fearful of the recycling system that is being implemented, especially in the grand malls, which from their point of view, could be highly deleterious. They seem so overwhelmed by everyday life, that the only vision of the future they have is for the next generation and not for their own. Such radical, real concerns represent an oxymoron compared to both economic and time investment towards the care of pigeons and their homes, but probably the driving force of Cairo lies in its strident contradictions.



Fig.1 – Garbage city seen from a high point of the area, next to the Monastery of San Simon. Copyright to the author.





Fig.2 – Wasseem, the owner and the Koka Tower. Copyright to the author.

## THE WOODEN PIGEON TOWERS

The *Burj Al Hamam*, pigeon towers, are rooted in an ancient Egyptian tradition that continues to thrive today. According to Elinor Husselman, "the raising of pigeons, both for food and for the production of manure, was widespread in ancient Egypt, as it is in Egypt today, and the dovecotes at Karanis were both large and numerous" (1953). Although the traditional mud-brick<sup>6</sup> construction methods are still in practice, Cairo's modern landscape is now predominantly characterized by wooden pigeon towers. The cultural significance of raising pigeons remains integral to Egyptian society, particularly among communities of the red-bricks neighbourhoods: the interest lies in flying competitions. This is indeed the function of these self-built wooden towers that rise as high as possible (even 25-30 m high). From an informal discussion with some pigeon tower owners, the goal seems to be to build a new floor and race with the most beautiful and smart pigeons.

The wooden structures are modular, anchored to the roofs with metal joints on which cement is poured: an improvised connection that anchors to what remains of the roofs of unfinished buildings, from which the pillars expose their reinforcement, meeting that ideal of growing in height. We might compare this thought of perennial growth to that of the no-stop cities<sup>7</sup>, which used infinite modularity as a provocation to the proposals of the ideal modern city in the 1960s. Here the provocation is not designed, as well as these structures themselves are not designed.

## THE "KOKA" PIGEON TOWER

*On-site interview with Mr. Waseem (interview mediator Patrycja Dybich), conducted in Garbage City, Cairo, in [September/2024]. The narrative description is a result of the insights gathered from on-site visits and informal discussions.*

The "Koka" tower in Garbage City (Fig.2) is positioned near the entrance, rising approximately 12 metres above the roof of a skeletal building that serves as a plastic recycling center (Fig.3). Mr. Waseem, the owner of the recycling centre and the pigeon tower, proudly

emphasises that all incoming waste is pre-sorted and cleaned. To demonstrate his success, he enthusiastically shows pictures on his phone of his new residence in New Cairo, from where he continues to come to Garbage city everyday to oversee both his recycling facility



Fig.3 – Mr. Waseem plastic factory in Garbage city (pigeon tower is on the roof of this building). Copyright to the author.





Fig.4 – View from the first floor of the “Koka” pigeon tower. Copyright to the author.

and the pigeon tower, for which his employees are also responsible. The tasks they have to perform for the animals well-being are indeed diverse and solved by simple and effective technologies.

Climbing the stairs of the tower, the effectiveness of the porous module, not rigorous, but possibilistic, becomes evident: the structure under analysis is divided in plan into 9 sections, each approximately 2.00 m x 2.00 m x 2.00 m high. This modular design, developed through the wooden framework, accommodates essential domestic functions: cables are pulled among pillars to dry clothes, while another module incorporates integrated LEDs into the beams, which also serves the drainage system with pipes. Additionally, the space is personalised with a video camera and a life-sized photo of Mr. Waseem, reflecting both the practical and personal elements embedded within the structure. As the structure rises, it appears to frame the surrounding neighbourhood, offering a distinct perspective of the crowded road beside it, buildings drowned by garbage bags, and the mountain looming in the background, offering a sense of authority and protection. The experience of rising and observing, evokes the feeling of participating in a contemporary art exhibition, close to visiting modern galleries, such as the Guggenheim in New York. This deep contrast, abstracts the author from the raw, chaotic context of the environment (Fig.4).

As we ascend the stairs - each step with a rise and tread of 20 cm - the modular structure fragments, and each floor gradually shifts toward more functional purposes. This transformation of space allows for a growing focus on practical needs, reducing the emphasis on modularity in favor of fulfilling the demands of daily life, such as pigeon care and living space. The space transitions into a room, the “gheya”, (Fig.5), where the less valuable pigeons are kept for hatching eggs. This space is organised as a corridor of cages,



Fig.5 – The gheya. Copyright to the author.



Fig.6 and 7 – The entrance of the humans' living room in the pigeon tower and the mashrabiya of the pigeon tower's roof. Copyright to the author.



equipped with a watering system powered by pipes connected to a small water tank. The tank is regulated by a valve that automatically refills the water supply as needed, constantly ensuring the birds' necessities.

On this particular floor, Mr. Waseem has established a quintessential Egyptian living space. Beyond a wooden door intricately decorated with the figure of Jesus (Fig.6), lies a room encompassing three of the nine total floor modules (each measuring 2.00 m x 2.00 m x 2.00 m). This human-centric space is equipped with amenities like a mini-kitchen, refrigerator, TV, air conditioning, comfortable seating, and windows, still covered in protective foil, as many Egyptians would do. The stark contrast between the functionality of a pigeon tower and the presence of a spacious, convivial human area underscores the enduring Egyptian culture of hospitality and community, even in spaces primarily intended for ludic pigeon care.

Once the pigeon break is over, it is time to reach the last section of this architecture: the roof, where the pigeons fly free and then return, attracted by the red flag waved vigorously by Wasseem, who grabs them with a system of traps, which he manages to activate by hiding in a very special mashrabiya<sup>8</sup> (Fig.7). The magic that can be perceived in this place, in every moment, the path from the bottom to the top, the flight of the birds, with the attention towards their capture and care, does not rationally explain how it is possible to invest so much in an architecture that is a playground, a heterotopia (Foucault, 1967) that ideally transforms the destiny of unprivileged places, in a silent and shared way, transporting the inhabitants from garbage city to the place of possibilities. Even their definition as Zabbaleen (literal translation is garbage people), cannot be fair to these inhabitants, as many are in fact claiming their right to be called instead the cleaners of the city, as suggested by Father Samaan<sup>9</sup>.

The pigeon tower has a notable

urban impact, operating as a landmark on the rooftops of a neighbourhood defined by unfinished, red-brick buildings, with no architectural differentiation (Fig.1). The structure's towering height, its association with communal joy, and the role of religious practices may serve as catalysts, fostering a sense of community through the social participation among local residents. Although it is situated on a private property, the towers promote a sense of openness and inclusivity: neighbourhood residents often gather in their human living rooms, or climb all the structure to witness the sunset and take photographs. Beyond its architectural presence, the tower facilitates social cohesion and mutual respect, reinforced by pigeon-flying competitions

During these events, each pigeon is marked with a ring bearing its owner's identification, and when a pigeon inadvertently joins another tower, it is promptly returned to its home - a practice that strengthens community bonds (Angélil and Malterre-Barthes, 2018; Rancière J., 2022).

## CONCLUSIONS

The case study of the pigeon tower in Garbage City provides a profound reflection on how informal architectures can challenge conventional urban paradigms and contribute to restoring porosity in Greater Cairo. While this study does not focus on the modern development of New Cairo, which would require a more in-depth analysis, it instead emphasises the potential of "architecture without architects" (Rudofsky, 1964). In this context, porosity is not limited to the physical accessibility and permeability of spaces, but also encompasses social openness that facilitates the free flow of human interaction across different social classes. This dynamic helps restore a sense of community based on shared ideals, rather than capitalistic power structures.

The pigeon towers create not only a unique physical space but also an environment where social

connections can flourish. Through the shared practice of pigeon racing, residents of Garbage City are brought together, fostering a sense of community and strengthening social bonds. These towers offer a space for collective engagement that transcends the boundaries of private property, promoting social cohesion, qualities often absent in the new privatised urban developments such as the ones in New Cairo. This example illustrates how informal spaces, born out of improvisation, contribute to community cohesion and collective engagement (Benjamin and Laci, 2020).

Although the pigeon towers are physically separated, each belonging to private properties, they remain interconnected through their shared purpose and competitive spirit. Their modular, possibilist design, similar one to the other, allows for the individual expression through the decorations; this adaptability aligns with the principles of rhizomatism (Deleuze & Guattari, 1980), where each component within a structure has the potential to connect to others, forming a decentralized, non-hierarchical network. These structures evolve according to individual needs, while maintaining a connection to the broader community, allowing for both personal and collective growth.

To reinforce the abandonment of hierarchical systems and encourage porosity, the concept of urbs is central. As Cerdà (1980) articulates, the terminology urbs examines the relationship between space, humanity, and the social fabric, advocating for a departure from traditional, hierarchical classifications of human settlements. In the case of Cairo, particularly through the example of the pigeon towers in Garbage City, we see how informal architecture transcends these rigid classifications. The absence of strict architectural discipline, combined with a strong sense of community, transforms the pigeon towers into living representations of utopian ideals on which cities should be based, such as social equality, inclusivity, and spontaneous,

organic community building. These ideals challenge the conventional top-down planning that often dominates urban developments. The towers act as heterotopias (Foucault, 2010), where the boundaries between private and public, individual and collective, are blurred, creating a space for shared goals and mutual support.

Informal structures could serve as the foundation for contemporary urban environments in Greater Cairo, integrating porosity and inclusivity into all designed spaces; while European urban theory often emphasises the genius loci<sup>10</sup> (the spirit of place), Cairo's contemporary culture tends to focus on technological progress, security, and comfort (Cavalletti, 2020). However, by integrating traditional, spontaneous structures and intangible values into urban planning, a common ground could be found that fosters deeper connections with both the environment and the community.

This paper highlights the potential of informal structures to challenge conventional urban paradigms. Further investigations will extend this study to other examples of non-architecture, continuing to explore how such spaces, rooted in intangible community practices, can represent a silent revolution to restore porosity in our communities and urbs.

## NOTES

1. Greater Cairo is the metropolitan area that includes New Giza, Giza, Cairo, New Cairo, New Capital (UNHSP, 2012).

2. Compounds are residential and commercial areas, physically defined by walls and gates: access is guaranteed only to certain social classes and they generate gated communities, "a form of residential community or housing estate containing strictly controlled entrances for pedestrians, bicycles, and automobiles, often characterized by a closed perimeter of walls and fences." (Angélil M. 2018)

3. Urbs, from Latin, means City, used in this paper, as terminology to refer to a non-hierarchical system, in the loosest and most general sense possible, to include all the different elements that belong to the complexity of Cairo (Cerdà I., 1867).

4. Gilles Deleuze e Félix Guattari coined the word "rhizome" (1980) in philosophy,

to indicate a network that can expand in different directions and doesn't have a hierarchical or linear organization.

5. Manshiyat Naser, commonly referred to as "Garbage City," is a terminology used in this paper purely for practical clarity. However it might result offensive and stigmatizing, reducing the community's identity to its waste management role.

6. Egyptian ancient brick, sun-dried, composed by Nile alluvium or desert, sediments/clays, sand, and water (Emery V., 2011)

7. No Stop City, an urban project not realized by Archigram, 1960, has strongly impacted the architectural community.

8. Mashrabiya is a typical Arabic architecture element, which with its wooden structure provides soft light, ventilation and privacy.

9. Father Samaan was a priest that founded the cave church in garbage city, which opened the city to many tourists' visits.

10. Genius Loci, understanding and analyzing a space starting from their physical, historical, cultural characteristics.

## REFERENCES

ANGÉLIL, Marc, and MALTERRE-BARTHES, Charlotte. *Cairo Desert Cities*. In collaboration with Something Fantastic and the CLUSTER. Basel: Ruby Press, 2018.

BENJAMIN, Walter, and LACIS, Asja. *Napoli Porosa*. Edited by Hannelore Schwyer. Rome: Edizioni Cronopio, 2020. First edition in 1925.

CAVALLETTI, Andrea. *La città biopolitica: Mitologie della sicurezza*. Milan: Mimesis, 2020.

DELEUZE, G., & GUATTARI, F. *A Thousand Plateaus: Capitalism and Schizophrenia*. London: Continuum, 2008. Originally published as Mille Plateaux, volume 2 of Capitalisme et Schizophrénie. Paris: Les Éditions de Minuit, 1980.

EMERY, Virginia L., 2011, *Mud-Brick Architecture*, Los Angeles: UCLA Encyclopedia of Egyptology

FOUCAULT, Michel. *Eterotopia*. Milano-Udine: Mimesis Edizioni, 2010. First published as Des espaces autres ("Of Other Spaces") in 1967.

GLASER, Barney G., and STRAUSS, Anselm L. *The Discovery of Grounded Theory: Strategies for Qualitative Research*. Chicago: Aldine Publishing Company, 1967.

HUSSELMAN, Elinor M. *The Dovecotes of Karanis. Transactions and Proceedings of the American Philological Association*, vol. 84, 1953, pp. 81–91. Baltimore: The Johns Hopkins University Press.

PIFFERO, Elena. *Participation: Empowerment or Domestication? Reflections on Potentials and Potential Shortcomings of Participatory Approaches to Development*. In: Participatory

Development Programme in Urban Areas (PDP). Cairo: Deutsche Gesellschaft für Technische Zusammenarbeit (GTZ) GmbH, 2009.

RUDOFISKY, Bernard. *Architecture Without Architects: An Introduction to Non Pedigreed Architecture*. The Museum of Modern Art, 1964. Distributed by Doubleday, Garden City, N.Y. Available at: [www.moma.org/calendar/exhibitions/3459](http://www.moma.org/calendar/exhibitions/3459).

SIMS, David. *Understanding Cairo: The Logic of a City Out of Control*. Cairo: American University in Cairo Press, 2012.

SMITH, Peter K., "Does Play Matter? Functional and Evolutionary Aspects of Animal and Human Play." *Behavioral and Brain Sciences*, vol. 5, no. 1, 1982, pp. 139-155. Cambridge University Press. <https://doi.org/10.1017/s0140525x0001092x>.

UNITED NATIONS HUMAN SETTLEMENTS PROGRAMME (UNHSP). *Greater Cairo Urban Development Strategy*, 2012. [https://unhabitat.org/sites/default/files/documents/2019-05/greater\\_cairo\\_urban\\_development\\_strategy.pdf](https://unhabitat.org/sites/default/files/documents/2019-05/greater_cairo_urban_development_strategy.pdf).

UNITED NATIONS HUMAN SETTLEMENTS PROGRAMME (UN-HABITAT). *Country Profile Egypt*. Nairobi: UN-Habitat, 2016. <https://unhabitat.org/sites/default/files/download-manager-files/Country%20Profile%20Egypt%20English.pdf>.

UNITED NATIONS HUMAN SETTLEMENTS PROGRAMME (UN-HABITAT). *Greater Cairo: Urban Development Strategy*. 2006

[https://staging.unhabitat.org/downloads/docs/8635\\_42944\\_AymanEl-hefnawi.pdf](https://staging.unhabitat.org/downloads/docs/8635_42944_AymanEl-hefnawi.pdf).

World Bank - Sustainable Development Department, Middle East and 027 North Africa Region (2008). Arab Republic of Egypt: Urban sector update, vol. 1. Available at [www-wds.worldbank.org/external/default/WDSContentServer/WDSP/IB/2008/07/03/000334955\\_2008070307595\\_9/Rendered/PDF/E14370v30REPLA105B0Report1June12007](http://www-wds.worldbank.org/external/default/WDSContentServer/WDSP/IB/2008/07/03/000334955_2008070307595_9/Rendered/PDF/E14370v30REPLA105B0Report1June12007)

## CONSULTED BIBLIOGRAPHY

BRANZI, Andrea. *Una generazione esagerata: Dai radicali italiani alla crisi della globalizzazione*. Milan: Baldini & Castoldi, 2014.

FARNSWORTH, Michael S., and Gagnon, John M. (Eds.). *Understanding Cairo: The Logic of a City Out of Control*. Cairo: American University in Cairo Press, 2012

MITCHELL, Don. *The Right to the City: Social Justice and the Fight for Public Space*. New York: Guilford Press, 2018.

RANCIÈRE, Jacques, and others. *Radical Pedagogies*. Edited by Kevin Lamb, Lisa Robertson, and Daniel Scharpenburg. Cambridge, MA: MIT Press, 2022.

SENNETT, Richard. *The Uses of Disorder: Personal Identity and City Life*. New York: Alfred A. Knopf, 1970.



**AIRBORNE,  
MULTISENSORIAL  
AND  
PSYCHOLOGICAL  
ARCHITECTURE**



# Radicalism and Freedom in Low-Tech Architecture

A Kantian perspective

low-tech architecture  
design motivations  
freedom paradigm  
natural materials  
psychology of design

This paper investigates the intersection of radicalism and freedom in low-tech architecture through psychological and philosophical perspectives, particularly those of Immanuel Kant. It is based on interviews with leading figures in the low-tech movement, which is typically associated with constructions using straw, unfired earth, bamboo, or other unprocessed materials, sometimes referred to as 'natural,' 'recycled,' or 'bio-based.' The study explores the motivations and paradigms among prominent architects and builders involved in this movement, who prioritise minimalism, environmental sustainability, and autonomy from conventional systems. The research highlights the emphasis low-tech practitioners place on individual empowerment, creativity, and ideological commitment, contrasting with mainstream architectural practices.

The study underscores the importance of integrating psychological and philosophical dimensions into architectural research. It proposes that insights from this humanistic approach, grounded in the assertion that technological problems are often not purely technological, could bridge the gap between low-tech and mainstream construction. The paper aims to enhance understanding and integration of sustainable practices to address the climate crisis by examining the value systems, narratives, and communication strategies of low-tech proponents.

**Kołąkowski, Marcin Mateusz<sup>1</sup>**

<sup>1</sup> Lincoln School of Design and Architecture / University of Lincoln, United Kingdom.  
<https://orcid.org/0000-0001-7244-1479>  
[mkolakowski@lincoln.ac.uk](mailto:mkolakowski@lincoln.ac.uk)

Citation: Kołąkowski, M.M. (2024). "Radicalism and Freedom in Low-Tech Architecture", UOU scientific journal #08, 80-91.

ISSN: 2697-1518. <https://doi.org/10.14198/UOU.2024.8.09>  
This document is under a Creative Commons Attribution 4.0 International license (CC BY 4.0)

Article Received: 16/09/2024  
Received in revised form: 28/09/2024  
Accepted: 09/11/2024





## INTRODUCTION

### Objectives and Structure

The responsibility of the construction industry in the context of the climate crisis has been discussed for decades. Over 50 years after publication of – *The Limits to Growth* (Meadows, 1972) – a seminal analyses on finite supply of resources according to a 2023 UN report, building and construction is the largest emitter of greenhouse gases, accounting for approximately 37% of global emissions, with Portland cement production alone contributing 7-8% (UN Environment Programme and Yale Center for Ecosystems and Architecture, 2023). There is a long history of researchers and practitioners searching for solutions to this problem in architecture (Pelsmakers et al., 2022; Baillieu and Zogolovitch, 2023; Roaf et al., 2017). Surprisingly however, one of the most radical architectural movements for over five decades advocating for a complete cessation in the use of materials that significantly contribute to greenhouse gas emissions remains marginalised. This direction, promoted by designers and activists of this movement, will be referred to as the 'low-tech' movement for the purposes of this article. It emphasises the use of materials such as unfired earth, sand, waste materials, or bio-based products like straw, reed, and bamboo. It challenges the dominance of high-embodied energy materials by offering solutions rooted in sustainability and resource conservation (Fowles, 2021).

However, low-tech architecture goes beyond technological solutions and material use. While conducting research, adopting psychological perspectives on motivations and understanding psychological paradigms allows for light to be shone and for comprehending the character of this movement (Kołakowski, 2019; Kołakowski, 2016; Kołakowski, 2021). Enthusiasts of this movement often critique mainstream construction solutions and industry practices profoundly. Architects engaged in low-tech

often express a commitment to environmental stewardship and social justice, joblessness, seeing their work as a form of activism, which is visible in collections of essays prepared by Elizabeth and Adams (2000), and other publications that mix environmental concerns, ideological standpoints, and technical solutions such as building from unfired earth (Evans et al., 1990; Minke, 2021), straw (Steen et al., 1990; Jones, 2015), or waste materials (Prinz, 2015).

One key theme in these publications is the authors' subjective critique of how mainstream construction often limits the freedom of users and builders. This limitation, in their opinion, is largely due to dependency on subcontractors and off-the-shelf solutions, which undermine individualism and skill. Low-tech design promotes self-building as a means of fostering independence (Grahame and McKean, 2020). The idea of "robust architecture" aims to free users from reliance on maintenance subcontractors (Haselsteiner, 2023). Low-tech promoters also want to free users from financial dependency and advocate for financial alternatives to standard procurement methods, suggesting mutual aid among neighbours or incorporating future users' labour into the construction process to reduce costs (Leeor, 2023). These techniques allow for a high level of individualisation in form, aesthetics and functionality which, among low-tech enthusiasts, is often defined as 'freedom'.

Despite its potential, the low-tech movement remains under-researched and misunderstood. As Sun et al. (2023) argue, 'the extensive integration of straw bale constructions into the mainstream market faces challenges from various sectors of the construction industry. Perhaps one issue lies in the research directions themselves. So far, the literature on low-tech architecture can be categorised into three main areas: 1) practical guides on construction techniques; 2) studies examining the aesthetic and design aspects of low-tech

buildings; and 3) technical research on the physical properties of these structures, including their thermal performance, energy efficiency, breathability and retrofitting methods. However, these technical analyses often lack engagement with research offering psychological perspective of the low-tech movement.

This paper seeks to pave the way for further exploration of the low-tech movement by adopting a humanistic approach, grounded in Martin Heidegger's assertion that the problems of technology are often not technological in nature (Heidegger, 1982). The study will examine the value systems, narratives, and communication strategies of prominent low-tech proponents, with a particular focus on key concepts such as radicalism and freedom, and how these ideas are understood and applied in practice. It aims to shed light on how these concepts form a mind map of low-tech creators. It is believed that this humanistic perspective could lead to better understanding and communication between low-tech advocates and the mainstream construction industry, potentially bridging the gap between these sectors and enabling the adoption of more sustainable solutions to address the climate crisis. Improved communication and shared understanding of low-tech principles may eventually facilitate the integration of its methods into mainstream construction.

Before addressing the methodology and discussing the findings, it is essential to outline the philosophical concepts that underpin this research and the criteria against which the discussion will be evaluated. For this reason, the definitions of "freedom" and "radicalism" as they are used in this paper will be defined in the following sections.

### Definitions of Radicalism(s)

The concept of 'radical,' deriving from the Latin word *radix* (meaning 'root'), prompts the question: Should something be planted at the root, or should the root be

entirely uprooted? And, if so, what should replace it? Radicalism, as an idea, holds strong appeal for many political, ideological, artistic, and architectural movements. It is often seen as a powerful force capable of driving innovation and change. However, radicalism is a double-edged sword, with both constructive and destructive potential.

On one hand, radicalism can be a positive creative process. Philip Plowright, a theorist of design methods, defines "first principles reductions" as a tool that simplifies situations to their core principles, allowing a fresh understanding of design tasks. This approach, can suspend reflexive responses, focusing on essence instead of form (Plowright, 2014). The value of returning to the origin of first principles was acknowledged long before modern theories of creativity: 'That from which a thing can first be known is also called the origin of the thing... for the good and the beautiful are the origin both of knowledge and of the movement of many things' (Aristotle, 1984). This concept of principle-based

creativity was echoed by Marc-Antoine Laugier, often considered the first modern architectural philosopher. In *The Primitive Hut*, Laugier argued against classical borrowing and advocated for radical rethinking in architecture (Germann, 1974).

This radical approach influenced 20th century modernism and some postmodernists who embraced radicalism as a core method, even when opposing modernist ideas (Jencks & FAT, 2011). These ideas have often freed thinking from established patterns in terms of functionality and allowed attention to be drawn to significant architectural and urban issues. Today, faced with environmental and social crises, a different type of radicalism is emerging, focused on rethinking the role of modern technology. Architects in the low-tech movement suggest, however, an answer very different from the mainstream by radically questioning the necessity of technologies which are energy-intensive, produce CO<sub>2</sub> and waste and are difficult to deal with after demolition (Fairs, 2020).

Radical ideas related to freedom have left significant - though not always positive - marks on architecture: Nero's destruction of Rome to free the city of Christians, Fascist architecture aimed at creating a world free from Jews, and radical communist projects seeking to liberate populations from bourgeois oppression through collective housing. Even political movements like the National Radical Camp in Poland used the notion of radical freedom in exclusionary and destructive ways against minorities. Paradoxically, various political, ideological, and religious movements advocating radical freedom have often resulted in suffering and misery rather than happiness. The concept of radicalism alone does not guarantee personal growth, creativity, or happiness. Since freedom is a key element in many forms of radicalism, evaluating radicalism requires a framework that differentiates and examines the various types of freedom it promotes, both in ideologies and in architecture.

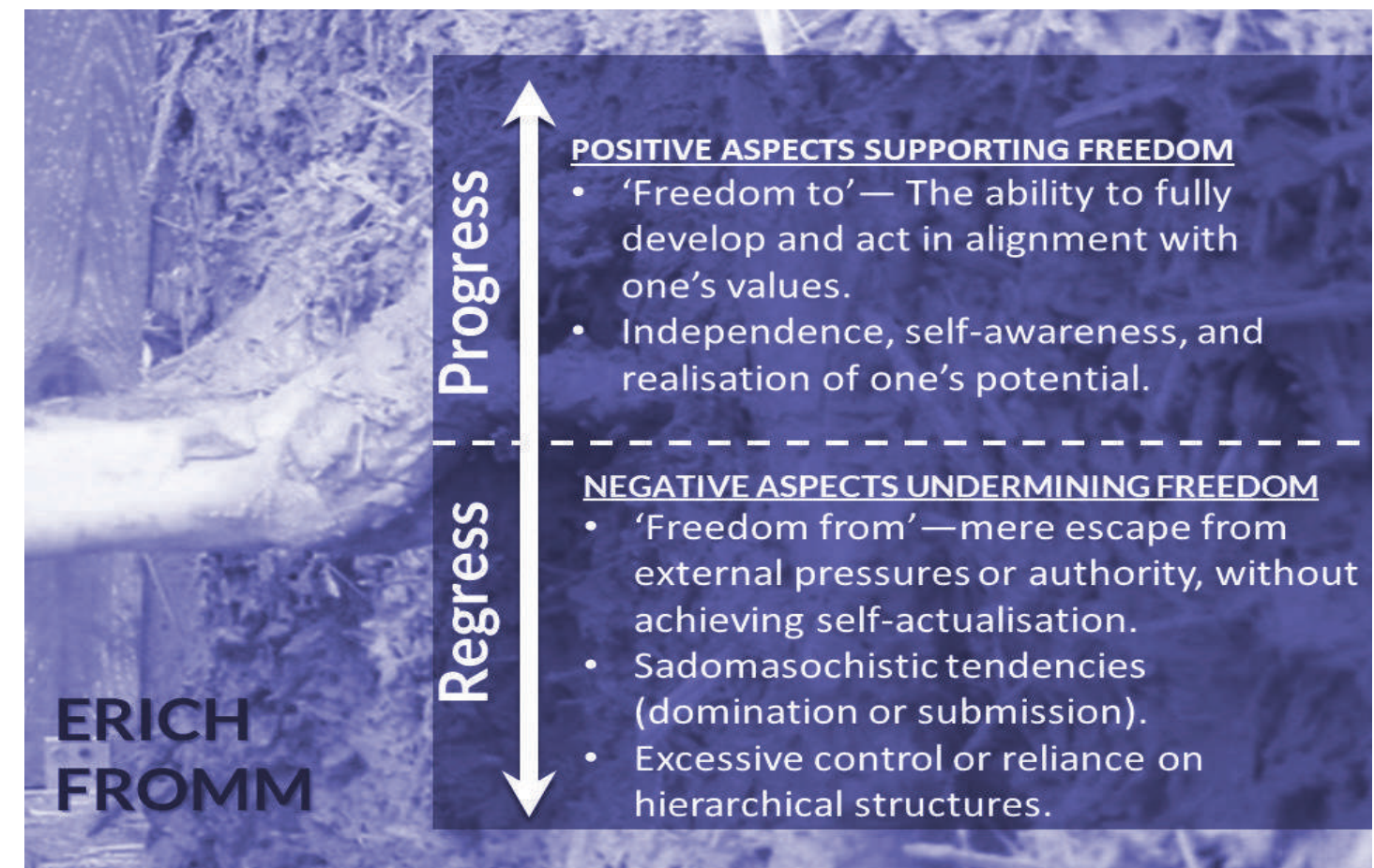

Fig.1 – Definition of Freedom in the work of Erich Fromm – Source: Image by the author (2024).



## Definitions of FREEDOM

Since the Enlightenment with works by Immanuel Kant and John Stuart Mill, who claimed that 'individuals ought to be free to do as they wished unless they caused harm to others' (Mill, 1859, pp. 21–22), and through historical moments like the *American Declaration of Independence* or the construction of the Statue of Freedom, freedom became a central axiom of the Western world. As an axiom, it appears for many to be one indivisible idea.

However, several thinkers, particularly in the field of psychology, have challenged the unity and indivisibility of this concept. One of the most fundamental contributions came from Erich Fromm (Fig.1). In his work *Escape from Freedom*, Fromm makes an important distinction between 'freedom from' - merely the escape from external pressures or authority - and 'freedom to' - the ability to fully develop one's potential and act according to one's values (Fromm, 2001). In *The Anatomy of Human Destructiveness*, Fromm warns that radical 'freedom from' can devolve into sadomasochism, conformity, and authoritarianism, arising from a blockage of possibilities and a desperate attempt to create space for oneself (Fromm, 1997). Psychologists like Crossman, Sullivan, and Boyd echo this view, suggesting that radical reactions, often seen as pursuits of freedom, are triggered by frustration and anger when personal goals are thwarted (Crossman et al., 2009; Boyd, 1982). This psychological lens can be applied to creativity.

A designer whose creativity feels constrained may propose radical solutions aimed at unrestricted artistic expression, even at the expense of user freedom. On the other hand conversely, some designers might deliberately impose limits on their freedom - such as restricting material choices or technologies - to radically enhance the freedom and creativity of users. This psychological perspective is philosophically grounded in

Immanuel Kant's distinctions of freedom in *Critique of Pure Reason*. For Kant, freedom is not merely the absence of coercion but the capacity to act according to reason, in line with self-imposed moral principles (Kant, 1998). Kant's concept of 'freedom' is thus the foundation of moral autonomy, a key idea that will inform the discussion of freedom and radicalism in this paper (Fig.2).

## OBJECTIVES AND METHODOLOGY

### Objectives

This study aims to explore the value systems and narratives surrounding the low-tech architectural movement, with a particular focus on the concepts of freedom and radicalism. By analysing interviews with some of the most well-known low-tech designers, the study investigates how these ideas are conceptualised in contrast to mainstream architecture and how they are adopted both in their professional practice and personal lives as designers.

The research employs grounded theory, which allows hypotheses to emerge from collected data, rather than being preconceived (Strauss and Corbin, 1994). It seeks to conceptualize what is occurring in the lives of participants rather than aiming for definitive truths (Martin and Turner, 1986). In this study, grounded theory facilitated an exploration of the personal and professional narratives of the interviewees.

### Choice of Respondents

The study is based on an analyses of work and interviews with ten acclaimed low-tech designers. Selection criteria required that respondents chosen for this research have at least seven years of experience, be recognised within the low-tech movement, and possess significant achievements, such as publishing books or having their work discussed in relevant forums (Fig.3). Additionally, respondents had to be actively

involved in the movement, participating in workshops, conferences, and other public engagements. These publications, events, and specific works cannot be named for reasons of anonymity

Interviews were conducted either in person or online, with participants given the choice of format. Respondents were informed that anonymity was an important part of this research, but they were also made aware of their right to opt out at any time. Semi-structured interviews allowed for flexibility, though three core points were consistently addressed:

1. What sparked your interest in low-tech architecture, and what led you to join the low-tech movement?
2. How do you perceive the differences between mainstream architecture and low-tech architecture?
3. Additionally, participants were asked to comment on a statement about different kinds of freedom in architecture, which will be explained below.

### Anonymising and Non-anonymising parts of the Research

Due to the prominence of the respondents, interviews were anonymised to encourage honest, candid responses, even when discussing frustrations or failures. While some respondents initially expressed interest in non-anonymised publication for self-promotion purposes, it was clarified that the research focus required anonymisation to ensure reliable results. In some cases separate articles, unrelated to this study, were created, ensuring no overlap with the anonymised research data.

For this research, for purpose of anonymisation, responses were modified to prevent identification by replacing specific terms like "straw bale" or "earth construction" etc with the generic term "low-tech construction." Names of locations, companies, and countries were also altered. To provide a general

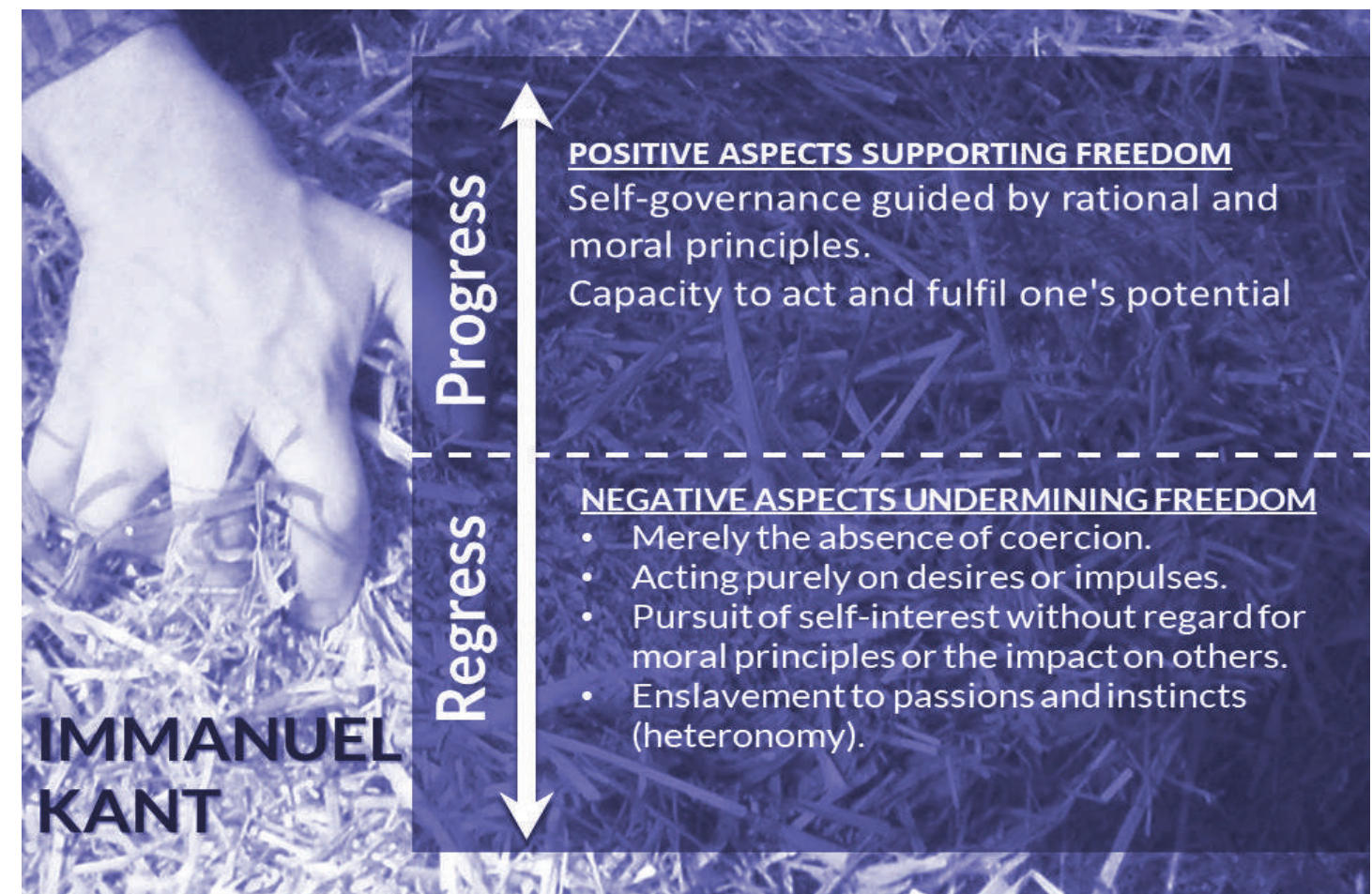

Fig.2 – Definition of Freedom in the work of Immanuel Kant – Source: Image by the author (2024).

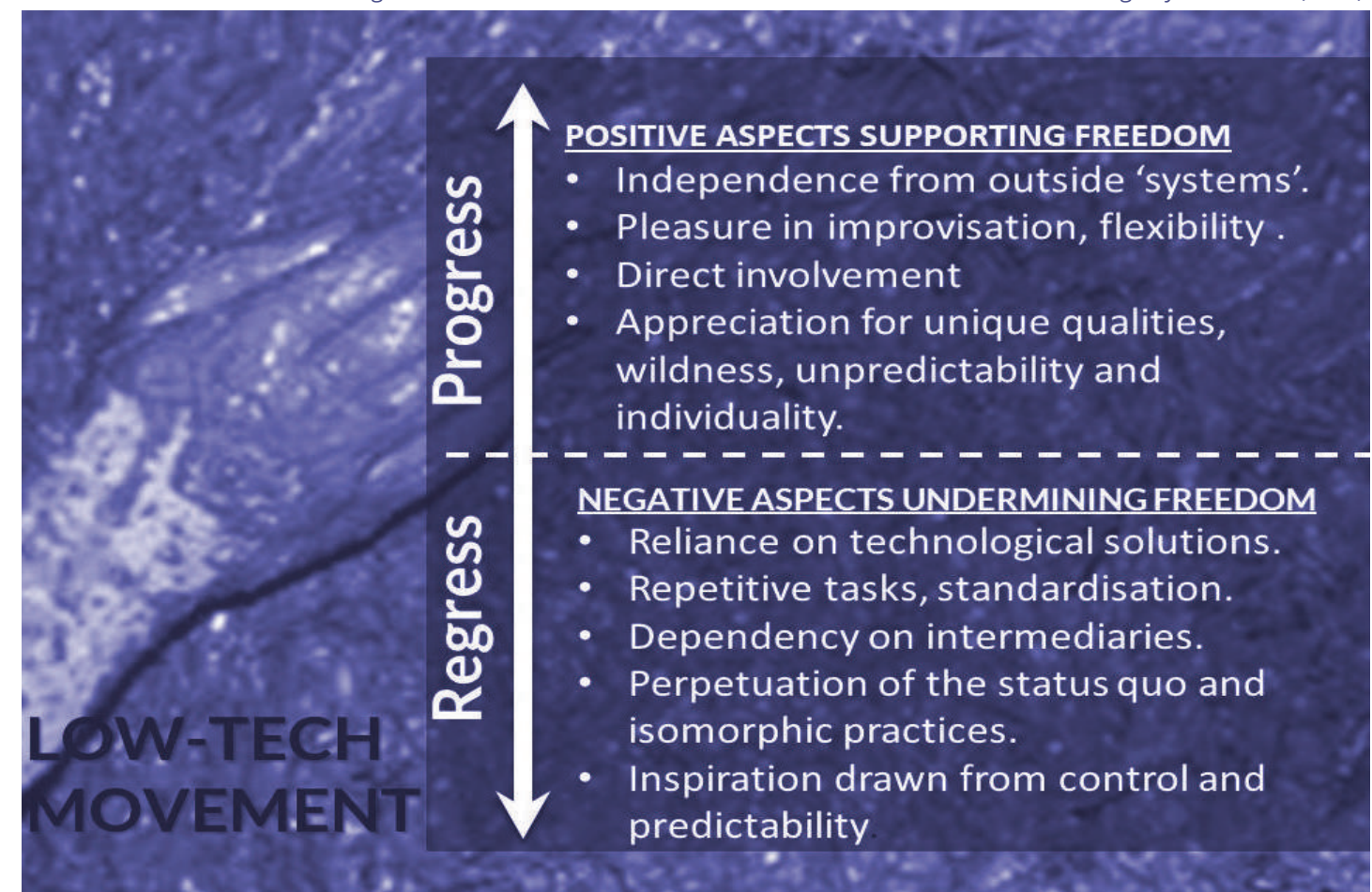

Fig.3 – The Low-Tech Movement – Source: Image by the author (2024).



overview, a generic table was created, showing the profile of each designer for the purpose of this publication (Fig.4).

## FINDINGS AND DISCUSSION

### Interest in Low-tech

Respondents were asked, "What sparked your interest in low-tech architecture, and what led you to

join the low-tech movement?" From their responses, two distinct groups emerged. The first one consisted of experienced designers who, despite achieving recognition and financial success in their previous work, expressed dissatisfaction and sought a more fulfilling path. The second group comprised designers who had committed to low-tech principles from the beginning of their careers. Several key themes were identified as similar for both groups:

1. A desire for independence from conventional systems.
2. A pursuit of a more fulfilling and supportive work environment.
3. A drive to redefine architectural practice as more than just a means of financial gain.
4. A need for greater personal identity and creative freedom through their work.

The responses from the first

group focused on the turning point in their professional careers:

*"The company I was working for was world-renowned, respected - everyone was talking about it. At the time, it was cutting-edge. Many people thought it was one of the best places in the world to work as an architect, but somehow, I wasn't fulfilled. I was part of very important discussions among famous opinion-makers in architecture, which were published in many architectural books. But there came a moment I was traveling to remote parts of the world and noticed how bad the conditions were that simple people were living in. I knew I could help them as an architect with the simple knowledge I had, but it wasn't the techniques used by those famous, cutting-edge companies. So, I thought hard about how to do it. One way was to suggest something architecturally affordable, not the expensive. It was different way of being radical, different way of making different cutting-edge solutions. I decided to change direction completely. Working with a university and winning a decent grant helped to change my career path I keep working as an architect."* (Interview A)

*"I had a well-established job, but I wasn't happy about it. Being a woman on a building site is not always a great experience in the masculine, macho environment. So, I went abroad on one low-tech gathering, and I got very excited. I found something less competitive, less macho, and more collaborative. Immediately, I felt I had found something for myself, and I decided to completely change the profile of my company and, in a sense, rethink the way I worked."* (Interview B)

*"I was working in a well-established construction company in a big city. The job seemed decent, with a decent salary. But the work I was doing was so mundane and standard. Initially, I thought I could get used to it, but I couldn't. The more I worked, the more I hated it and myself. One day, something very strange and dramatic happened to me at work. My body just refused to do the job. I stopped working and couldn't talk or move. I know it was because of how much I hated the work. It was so severe that*

*my colleagues called an ambulance. After the incident, I realized I had to do something decisive with my life and career. First, I decided to take all my money and travel around the world. It took me over a year. I visited many places, thinking about what to do with my life. During the trip, I came across people who built with various low tech techniques. It was eye-opening. It was something where I could still apply my knowledge and skills, but it was so different - a complete change of career."* (Interview C)

The tendency to liberate themselves from the system of well-established companies raises the question: what kind of freedom were they seeking in the Kantian sense? If it were "freedom from," as defined by Erich Fromm, their motivation would be driven by the desire to simply quit their jobs - much like individuals experiencing burnout seeking to improve their well-being, do less work, or have more free time. However, the respondents did not abandon their profession. Instead, they continued to use their skills, finding a way to align those skills more closely with their personal value systems by engaging with newly discovered low-tech techniques. This alternative method of construction allowed them in their opinion to be more creative and more in tune with their own abilities.

Another aspect, which echoes Kant's definition of freedom as "the capacity to act according to reason, in line with self-imposed moral principles," is evident in responses that emphasised their ideologically driven motivations for the change. In this sense, this group of respondents shares similarities with the second group, who chose to engage with the low-tech movement at the outset of their careers, often driven even more strongly by ideological motivations:

*"Straight after my studies, I felt I needed something more, so I went on a trip abroad where I found courses that taught building with natural, unprocessed low-tech or techniques. I spent several months there, and that's where I built my first buildings. Even though I later studied to become a*

*qualified architect, this first experience showed me another way to be an architect. Later on, it turned out to be a much more attractive proposition to be free from corporate life."* (Interview D)

*"I read some texts during my studies about low-tech techniques, and they offered a very different approach from what we were learning. I liked it, and even during my studies, I was interested in how I could get involved in this movement and become a low-tech architect. I was never interested in working for a big corporation, I needed freedom and I was keen to do things with my own hands, to be independent, and to take my work into my own hands."* (Interview E)

*"I studied architecture, but during my final year, I was so convinced that I wanted to be involved with low-tech constructions and ideas that I didn't even see the need to finish my studies, even though I only had one final project left I have not finished that since I had so much more new work related to low-tech. I used the skills I acquired during my studies, but low-tech techniques opened up so many opportunities to be independent and connect with like-minded people. I shudder at the thought of sitting in a big office and losing all the opportunities to be creative as I am now."* (Interview F)

The interviews revealed a strong common theme: for many respondents, low-tech techniques were a form of discovery - a new and exciting way to utilize their skills and interests in architecture. They felt like pioneers, with all the characteristics that come with that role:

The methods of constructing these buildings were still not codified, leaving plenty of room for experimentation and finding new ways of doing things.

There was a lot of uncertainty, and financially these decisions did not always translate into better financial situations. However, the interviews convey that independence and the freedom to experiment were more important factors, leading them to make radical life decisions.

Interview Code	Short Description of the Respondent
Interview A	Architect with 40 years of experience in various low-tech construction methods.
Interview B	Builder of low-tech houses; award-winning and recognized promoter with 40 years of experience in multiple low-tech construction methods.
Interview C	Engineer and designer specialising in a specific low-tech technique, with 10 years of experience.
Interview D	Architect with 30 years of experience in a particular low-tech method.
Interview E	Architect, advocate, and chairman of a low-tech organisation promoting natural architecture; university lecturer with 7 years of experience.
Interview F	Activist, builder, designer, and promoter of low-tech construction, with 10 years of experience.
Interview G	Architect working in conventional architectural offices as well as utilising low-tech solutions, with 20 years of experience.
Interview H	Builder and designer primarily involved in the restoration and renovation of historic buildings; also experienced in various low-tech techniques.
Interview I	Architect who occasionally employs low-tech techniques in practice, with 15 years of experience.
Interview J	Low-tech designer with 10 years of experience, living in a house constructed using low-tech techniques.

Fig.4 – Table 1: Profile of Interview Participants Elaborated by the author (2024).



## LOW-TECH VS. MAINSTREAM

When respondents were asked, "What do you think is the difference between mainstream architecture and straw bale architecture?" it became clear that, from their perspective, the differences between low-tech and mainstream are significant.

Their answers revealed four main themes:

1. Experimentation & Directness, referring to both the ability to influence the project and the direct contact with other stakeholders during the design and building process.
2. The potential for pursuing environmental values.
3. A positive atmosphere on the building site.

### Experimentation & Directness

A recurring theme among respondents was the concept of directness, often contrasted with mainstream architecture's reliance on external systems, contractors, and protocols. In this context, Kant's idea of freedom - as the ability to make one's own decisions - reflects the value system expressed by the respondents:

*"There's quite a lot of difference. First of all, the low-tech techniques I know rely on your own work, not on the system, if you understand what I mean. They're based on DIY and allow for a lot of improvisation, which isn't possible in conventional building. I know what I'm talking about since I was involved in mainstream construction for a long time. Low-tech allows experimentation and you to be directly involved in creating architecture without needing experts, sophisticated tools, or procedures for everything. I like being on-site and reacting directly to what's happening. It also allows you to better address the individual needs of builders, clients, and specific places. For example, with hand-shaped architecture, you can literally leave your fingerprints on the*

*elevation when you plaster the wall"* (Interview G).

*"Sometimes I'm on the building site with just my A4 sketchbook and a pen, and I can manage the whole construction that way. I prefer it to using CAD drawings in the office. I'm more effective, and I can sketch everything the builders need. This way, I feel more like an architect"* (Interview G).

Some respondents mentioned that, despite their previous work being more radical in terms of form, they chose to transition to low-tech architecture:

*"In a certain sense, my previous work was maybe even more radical in terms of form. It was easier to show off and be proud of my designs. But still, I'm happier building with low-tech techniques. Even if the buildings don't look as spectacular, I feel more radical now"* (Interview A).

### Environment

Nearly all respondents emphasised environmental values when comparing low-tech to mainstream construction. Without delving into technical specifics, the key themes in their narratives include reducing CO<sub>2</sub> emissions, limiting waste, and avoiding hazardous materials - issues that were raised in nearly every interview:

*"Mainstream architecture is addicted to concrete. The concrete industry developed alongside regulations, and it managed to influence them in such a way that designers and builders are now forced to use concrete. Concrete is responsible for over 5% of all CO<sub>2</sub> production. If we want to reverse this trend, we need to find alternatives, and that's what low-tech techniques offer. We need to stop using concrete!"* (Interview B).

*"If we're serious about reducing CO<sub>2</sub> emissions, the only way is to promote low-tech techniques that don't rely on highly processed materials with high embodied energy."* (Interview C)

*"The difference is the waste. If you build with straw or unfired earth, the*

*buildings don't leave any problematic waste at the end of their life - they just compost. There's no need to send materials to a landfill; they can stay here."* (Interview H)

*"I feel so happy that the technique I'm involved in is healthy for me, for the people on-site, and for the environment. When you work with concrete, you need so much protective clothing, but here, if I touch earth, it's like skin therapy."* (Interview G)

The drive for sustainability, healthy living, and well-being are now universal human values, expressed across many ideas of contemporary architecture.

However, the radical aspect of low-tech, as identified in interviews, lies in the willingness to sacrifice other elements such as spectacular forms, cutting-edge technology, or speed of construction in favour of environmental sustainability, with a particularly strong focus on future generations and global responsibility.

While a more definitive evaluation would require nuanced research, it seems that low-tech methods could have potential to serve as an experimental platform for sustainable development. The practice strongly aligns with the 5 R's of the waste hierarchy - Refuse, Reduce, Reuse, Recycle and Rot but is especially radical in its commitment to "Refuse" and "Reduce," which are core principles (Johnson, 2013) rarely embraced as fully as they are in low-tech architecture.

### Atmosphere on the Building Site

Nearly all respondents eThe second major theme identified in the interviews was the difference in the atmosphere on the building site. Respondents noted this in the relationships between the various people involved in the design and construction, as well as in the way the project and construction process were managed:

*"I don't know of any other building techniques that attract and create as much excitement as working with*

*straw, earth, or bamboo. People who enjoy these materials are willing to spend weeks just learning and building together, simply for the joy of it."* (Interview E)

*"These workshops are driven by dreams of a better world where everyone can create their own homes, free from dependence on specialists, experts, and financial limitations. Whether these dreams are realistic is debatable, but the collaborative atmosphere in low-tech construction is certainly appealing. It's not just about building; it's about building relationships, which generates a lot of energy and fun."* (Interview I)

*"In our world, many people are unemployed, depressed, and feel useless. On the other hand, there's too much energy consumption and CO<sub>2</sub> production due to machines. Mainstream construction focuses on reducing labour and increasing the use of machines and highly processed materials. What we need, and what low-tech offers, are labour-intensive methods that don't rely on machinery. It's radical, but it makes sense."* (Interview A)

Several respondents, particularly women, highlighted that the dynamics on low-tech construction sites fostered a more inclusive and supportive atmosphere compared to the often macho culture prevalent in mainstream construction:

*"...On a mainstream building site, if you're a woman or different in any way, it can be tough. You might be ridiculed, disrespected, or even bullied. Since getting involved in low-tech, I've seen how different the atmosphere can be. There are more women on-site, and it's much more collaborative and supportive. It's empowering and much more enjoyable."* (Interview B)

*"...When I use low-tech materials in my designs, the dynamic on the building site changes. People listen to each other more, and the old macho culture is deconstructed."* (Interview I)

### Freedom of High-Tech vs. Freedom of Low-Tech

As part of the research plan, each respondent was asked to comment

on a statement to which they were asked to express their opinion: "Some people say that we are heading towards designing buildings that allow full control, including the manipulation of the micro-climate or shape, and this is what they identify as freedom. Others claim that new technology entails complexity and the need for experts, on whom we are becoming dependent, and hence takes away our freedom. What is your opinion on this?"

From the researcher's perspective, the question aimed to contextualize respondents and encourage discussion on the concept of freedom in relation to the technology used.

However, the responses were inconclusive, with no clear theme related to freedom emerging. Instead, a recurring theme was the respondents' scepticism about the usefulness of distinguishing between low-tech and high-tech. Some respondents even expressed a reluctance to categorise themselves as low-tech designers:

*"Well, I use low-tech in some aspects, like unprocessed materials, but at the same time, I don't mind using high-tech. It all depends on what you consider high-tech. We all use the internet to communicate, transportation to get to the site. I am also promoting photovoltaics, or grey water systems - those are very high-tech, and I'm happy to use them in my design."* (Interview D)

*"I do use other types of materials which you could call high-tech, but I try to limit them. Even if they are cheap from an economic perspective, I treat concrete like gold and try not to overuse it. I think a person can be good six days a week, but one day a week, you have to be a little bad."* (Interview I)

The question prompted very broad responses, allowing the respondents to express more philosophical viewpoints. The reactions to the question suggest that the focus of the interview is not on the technical aspects of the construction methods.

*"This question must be for a*

*technophobe, right? [laughs] I find a lot of technology to be a waste of time. When your home needs to be controlled from somewhere else, it feels like someone else is controlling how you live. It really limits your choices, doesn't it? Of course, we still need technicians to fix our electricians and to help with repairs, given where we are now. But when we talk about freedom, I think true freedom is not having to answer to anyone else."* (Interview J)

"...A lot of the building materials and components used in architecture are produced by massive corporations - mega-companies that control prices, management and engage in practices that aren't always ethical. I don't believe this approach aligns with the concept of freedom. I prefer focusing on smaller, community-driven initiatives, but I recognize that it's not always practical. Unfortunately, our world is increasingly dominated by these large companies. I don't like it but what can I do?" (Interview G).

*"This isn't about low-tech or high-tech; it's about understanding the context and needs of the moment and situation. Many high-tech solutions come with predetermined parameters, creating a sort of matrix or grid that is disconnected from the actual building site. We prefer to be inspired by the natural site conditions, where each tree interacts with its neighbouring trees or bushes"* (Interview J).

The initial analysis of responses reveals that the question sometimes prompted lengthy individual explanations and philosophical reflections. Respondents were generally hesitant to draw a clear opposition between low-tech and high-tech.

While they were comfortable using terms like straw bale, earth architecture, biobased materials, and natural architecture, the term "low-tech" seemed confusing and not entirely reflective of their work. Despite the lack of clear thematic categorisation, the question provided valuable insight into their value systems.



## CONCLUSIONS

The author acknowledges that research conducted in such an interdisciplinary field - encompassing technology, aesthetics, praxeology, psychology, and philosophy - cannot be comprehensive. Further, more rigorous investigations and evaluations of motivations and

paradigms will be necessary. Nevertheless, adopting the perspectives of freedom as defined by Kant and Fromm facilitates the identification of key narrative lines that emerge during discussions with low-tech practitioners. These narratives can be simplified and contrasted through dichotomies, distinguishing what these creators find valuable, desirable, and

attractive from what they perceive as undesirable or unattractive. This can be summarized in the table below (Fig.5): This research into the radical nature of low-tech architecture exemplifies an approach to freedom as defined by Immanuel Kant and described by Erich Fromm, suggesting a framework to illuminate the mindsets and motivations of

architects involved in low-tech practices.

It is evident that the individuals drawn to this movement form a distinct group characterised by entrepreneurial spirit, manual skills, a penchant for experimentation, as well as discomfort with conventional systems. Many interviews identified a correlation between their paradigms and the concept of freedom as described by Fromm or Kantian definitions. However, this does not imply that these subjective opinions represent all ideas and aspects of freedom within the low-tech movement.

It is crucial to recognise that the analyses are based on opinions rather than universally applicable facts. For example, the architecture produced by these practitioners may not address many of the challenges facing contemporary architecture and construction, despite their claims. This paper does not aim to propose architectural solutions but rather seeks to understand opinions and narratives and explore ways of communicating these ideas.

It could be suggested that to expand on this research, future studies could replicate the interview framework with architects and builders involved in the mainstream construction industry. This would provide a comparative perspective on the value systems and perceived freedom in design between the low-tech community and conventional practitioners.

Nevertheless, the inspirational value of low-tech architecture warrants attention and can be considered an important avant-garde research area for technology and construction. Understanding low-tech concepts could provide valuable insights for mainstream practices. Although often analysed from a technical perspective, this study underscores the importance of considering the psychological aspects - specifically the motivations and psychology behind low-tech approaches - and sets a foundation for further humanistic investigations into technical solutions that may not seem to have a technical essence.

## BIBLIOGRAPHY

Aristotle (1984) *Metaphysics*. In: Barnes, J. (ed.) *The Complete Works of Aristotle: The Revised Oxford Translation*. Princeton University Press, vol. 2, pp. 1552-1728.

Baillieu, A. and Zogolovitch, G. (2023) *How to Be an Architect Developer*. 1st edn. London: RIBA Publishing.

Boyd, T.L. (1982) 'Learned helplessness in humans: A frustration-produced response pattern', *Journal of Personality and Social Psychology*, 42(4), pp. 738-752. doi: 10.1037/0022-3514.42.4.738.

Crossman, A.M., Sullivan, M.W., Hitchcock, D.M. and Lewis, M. (2009) 'When frustration is repeated: Behavioral and emotional responses during extinction over time', *Emotion*, 9(1), pp. 92-100. doi: 10.1037/a0014614.

Elizabeth, L. and Adams, C. (2000) *Alternative Construction: Contemporary Natural Building Methods*. Toronto: John Wiley & Sons Inc.

Evans, I., Smith, M.G. and Smiley, L. (1990) *The Hand-Sculpted House: A Philosophical and Practical Guide to Building a Cob Cottage*. Chelsea Green Publishing Co.

Faggiolani, C. (2011) 'Perceived Identity: Applying Grounded Theory in Libraries', *JLIS*, 2(1), University of Florence. Available at: <https://doi.org/10.4403/jlis.it-4592>.

Fairs, M. (2020) 'Low-tech architecture explained: Unfired earth, bamboo, and straw', *Dezeen*. Available at: <https://www.dezeen.com> (Accessed: 5 May 2023).

Fowles, E. (2021) 'Make Low-Tech Our Mantra and Design Clean and Simple', *The RIBA Journal*, 15 July.

Fromm, E. (1997) *The Anatomy of Human Destructiveness*. London: Pimlico.

Fromm, E. (2001) *Escape from Freedom*. London: Routledge.

Germann, G. (1974) 'Review: On Adam's House in Paradise; The Idea of the Primitive Hut in Architectural History by Joseph Rykwert', *Journal of the Society of Architectural Historians*, 33(3), pp. 247-248.

Grahame, A. and McKean, J. (2020) *Walter Segal: Self-Built Architect*. London: Lund Humphries Publishers.

Haselsteiner, E. (2023) *Robust Architecture: Low Tech Design (DETAIL Special)*. De Gruyter.

Heidegger, M. (1982) *The Question Concerning Technology and Other Essays*. London: HarperPerennial.

Jencks, C. and FAT (2011) *Radical Post-Modernism: Architectural Design*. Chichester: Academy Press.

Jones, B. (2015) *Building with Straw Bales: A Practical Manual for Self-Builders and Architects*. 3rd edn. Green Books.

Johnson, B. (2013) *Zero Waste Home: The Ultimate Guide to Simplifying Your Life by Reducing Your Waste*. Scribner.

Kant, I. (1998) *Critique of Pure Reason*.

Trans. Guyer, P. and Wood, A. Cambridge: Cambridge University Press.

Kołakowski, M. (2019) 'Maslow in the Mud: Contrast between qualitative and quantitative assessment of thermal performance in historic buildings', Springer.

Kołakowski, M. (2016) 'How high is high-tech? How low is low-tech? And what is the difference?', Monograph 9 - Wnętrze Architektoniczne i Urbanistyczne a światło, 9, pp. 107-123. Wydawnictwo WST w Katowicach. ISBN 9788394209384.

Kołakowski, M. (2021) 'Low-tech - Freedom, Creativity & Love: Translating Erich Fromm's Psychoanalysis into Analyses of Architecture', *UOU Scientific Journal*, 1(1), pp. 114-131. Alicante University.

Leor, A. (2023) *Earthship Biotecture Bible: Everything You Need to Know About Sustainable Building*. Independent Publisher.

Martin, P.Y. and Turner, B.A. (1986) 'Grounded Theory and Organizational Research', *The Journal of Applied Behavioral Science*, 22(2), pp. 141-157.

Meadows, D.H., Meadows, D.L., Randers, J. and Behrens, W.W. (1972) *The Limits to Growth*. New York: Potomac Associates - Universe Books.

Mill, J.S. (1869 [1859]) *On Liberty*. 4th edn. London: Longmans, Green, Reader and Dyer. Archived 17 Nov 2022 Wayback Machine.

Minke, G. (2021) *Building with Earth: Design and Technology of a Sustainable Architecture*. 4th edn. Birkhäuser.

Pelsmakers, S., Hoggard, A., Kozminska, U. and Donovan, E. (2022) *Designing for the Climate Emergency: A Guide for Architecture Students*. London: RIBA Publishing.

Plowright, P. (2014) *Revealing Architectural Design: Methods, Frameworks and Tools*. Abingdon: Routledge.

Prinz, R.P. (2015) *Hacking the Earthship: In Search of an Earth-Shelter that Works for Everybody*.

Strauss, A. and Corbin, J. (1994) 'Grounded Theory Methodology: An Overview'. In: Denzin, N. and Lincoln, Y., (eds.) *Handbook of Qualitative Research*. 1st edn. pp. 273-284.

Sun, C., Gu, J., Dong, Q., Qiang, D., Chang, W., and Yin, X. (2023) 'Are Straw Bales Better Insulation Materials for Constructions? A Review', *Developments in the Built Environment*, 15.

United Nations Environment Programme and Yale Center for Ecosystems and Architecture (2023) *Building Materials and the Climate: Constructing a New Future*. [wedocs.unep.org/20.500.11822/43293](https://wedocs.unep.org/20.500.11822/43293) (Accessed: 11 September 2024).

Phenomena Often Described as Attractive and Desirable in the Low-Tech Movement	Phenomena Often Described as Unattractive and Undesirable in the Low-Tech Movement
Identity through Own Work: Defining identity by emphasising uniqueness and the work done in creation	Identity through Products: Defining identity through products, typically expensive and recognisable
Independence from Systems: Independence from technological systems	Reliance on the Latest Technological Advances: Standing on the shoulders of the latest technological achievements
Work should be ideologically driven and serve others	Work as a means to financial stability: Designer work primarily focused on financial gain
Unique Experiences: Enjoyment from discovery and unique work experiences	Repetition: Preference for repetitive tasks that simplify work.
Improvisation Technology: Scope for improvisation during design and construction	Standardisation: High-tech solutions offer easier and more efficient work through standardisation
Directness: Independent and direct involvement in the design and construction process, free from subcontractors and intermediaries	Indirectness: Dependency on intermediaries and subcontractors during architectural and construction processes
Fostering an Inclusive, Supportive Atmosphere: Creating a positive environment on building site and during design	Fostering an Exclusive and Hierarchical Atmosphere: An exclusive, sometimes oppressive environment on building site (e.g., "macho culture")
Being Present: Addressing basic needs and solving fundamental problems	Escapism: Creating solutions that escape from existing global problems
Affordable Solutions: Encouraging flexibility and creativity, and not discouraging experimentation during the creation process	Status Quo due to Price: Expensive solutions that cement the status quo, prevent change, and discourage creativity
Focus on Individual, Unique Qualities of the Place: Emphasis on the spirit of the place	Isomorphism: Interest in grid systems and standards imposed regardless of the place
Inspiration from Wildness, Nature, and Unpredictability	Inspiration from Control, Predictability, and Technology

Fig.5 – Table 2: Comparative Values in Low-Tech and Mainstream Architecture. Elaborated by the author (2024).



# Forgetting Acceptances

## On the Productivity of Moments of Crisis in Architecture

vizyoner  
mimarlık  
kriz  
deney  
Cloud 9  
visionary  
architecture  
crisis  
experiment  
Cloud 9

Bu çalışma; kriz anlarında kabulleri unutma eyleminin vizyoner mimarlıklar inşa etme potansiyelini sorgulamaktadır. Kriz anları, konvansiyonel yaklaşımlarla çözülemeyen olağanüstülüklerin gerçekleşmesine neden olur; bu nedenle bu durumlar keşfedilmemiş girişimlerin üretilmesini gerektirir. Mimarlık tarihi boyunca çok sayıda kriz, daha sonra vizyoner ana başlığı altında yer alabilecek deneysel, avangard, eleştirel, standart dışı ve daha birçok kavram olarak kuramsallaşan yaratıcı üretimler oluşturmuştur. Bu bakış açısından yola çıkan çalışma mimarlık disiplinini bir bilim laboratuvarı olarak vurgulamaktadır. Bilim kaosu üstesinden gelmek için karmaşık ağları anlamlandırmaya çalışırken, vizyoner mimarlık da kriz anlarının belirsiz ortamlarına deneysel üretimler ile çözüm bulmaya çalışır. Bu bağlamda vaka çalışmasını araştırma yöntemi olarak benimseyen çalışma, bir seri deneysel mimariye ve Cloud 9 laboratuvarına odaklanarak inşa edilmiş kavramsal çerçeveyi ileriye taşımayı amaçlamaktadır. Disiplinler arası bir ekipten oluşan Cloud 9, mevcut teknolojik olanakların yardımıyla tasarım ve çevre arasındaki sınırları bulanıklaştırarak küresel ısınma senaryolarına meydan okumaya ve performatif bir mimari elde etmeye çalışmaktadır. Ekibin tasarladığı standart dışı sistemler, kriz anlarının neden olduğu değerler setinin keşfedilmesine ve bu set üzerinden mimaride hangi kabullerin dışına çıktığının anlaşılmasına yardımcı olur. Çalışmanın sonucunda unutma eyleminin öncesi ve sonrası arasındaki ilişkiler çözümlenerek vizyoner bir girişimde bulunmaktadır.

This study brings into question the potential of the act of forgetting acceptances in the moments of crisis to construct visionary architectures. Moments of crisis make the extraordinary happen that cannot be solved through conventional approaches; thus, these situations require undiscovered attempts to be produced. Throughout the history of architecture, numerous crises have generated creative productions, that were later theorised as experimental, avant-garde, critical, non-standard and many other concepts that could be included under the main heading of visionary. Starting from this point of view, this study highlights the discipline of architecture as a science laboratory. As science tries to make sense of complex networks to overcome chaos, visionary architecture also attempts to find solutions to the uncertain environments of crisis with experimental works. In this context, the study which embraces the case study as research methodology aims to take constructed conceptual framework forward, by focusing on a series of experimental architectures and the laboratory of Cloud 9. Consisting of an interdisciplinary team, Cloud 9 tries to challenge global warming scenarios and achieve a performative architecture, by blurring the boundaries between design and environment with the help of current technological possibilities. The non-standard systems designed by the team help to discover the set of values caused by moments of crisis and to understand which acceptances were deviated from in architecture through this set. In the result of the study, an initiative is made visionary by deciphering the relationships before and after the act of forgetting.

**Pinar Akin, Ayşe Tuğçe<sup>1</sup>**

<sup>1</sup> Istanbul Technical University, Faculty of Architecture, Department of Architecture, Istanbul, Turkey.  
https://orcid.org/0000-0002-4440-9452  
pinara@itu.edu.tr

Citation: Pinar Akin, A.T. (2024). "Forgetting Acceptances", UOU scientific journal #08, 92-101.

ISSN: 2697-1518. https://doi.org/10.14198/UOU.2024.8.10  
This document is under a Creative Commons Attribution 4.0 International license (CC BY 4.0)

Article Received: 14/09/2024  
Received in revised form: 02/10/2024  
Accepted: 10/11/2024





## INTRODUCTION

*What if the stories written throughout the history were accepted as non-existent?*

*What if the acceptances were forgotten?*

History is mostly constructed of stories based on acceptances, which reference assumptions, major narratives and structuralist norms. These stories make the accepted ones visible, while leaving the door of the others open to oblivion and extinction. Although the history of the invisible, implicit or other is also being written at the present time unlike the past; history usually acts selectively while trying to establish a common fact. It draws boundaries on different scales, individualities and collectivities. Thus, it ignores other stories that networks can create by coming together with different relationships and covers other possible facts with an impermeable layer. To change and transform the past, present and future, and to reveal their possible potentials, it is necessary to destroy acceptances (Fig.1). By destroying acceptances, the boundaries of time and space is blurred and a path to timelessness is opened. In

this way, instead of written stories with acceptances, the unpredictable that comes after the unknown can emerge. So, how do the things that are destroyed and disappeared trigger the visionary?

Speaking about ways to deal with the past in a political sense, Araujo (2009) states that the power in memory as a selective process is quite complex and powerful. As tools of power, memory and forgetting are used to ensure political control. Therefore, forgetting serves as a political strategy. Like memory, forgetting is also a selective process. The act of forgetting is important in overcoming the distance between the past and the present and creating a new agenda. In this study, the act of forgetting is linked to the acceptances associated with architecture. As forgetting is necessary for progress in politics, forgetting acceptances in architecture is important to envision the future and to lead visionary architecture.

Etymologically, visionary means to envision the future. The term visionary in the context of architecture has a noble and long tradition. Visionary architecture consists of polemical drawings,

real or virtual models, texts about specific buildings or regions. It does not need to be physically constructed. Visionary architecture is created for a lot of reasons such as to add noise into the system, to make a political statement, to pursue a designer's unique architectural language, to achieve pedagogical goals. Visionary architects, who develop visionary architecture, contribute to a meta conversation (Spiller, 2008). In her book "A History of Future", Goodman (2008) talks about the importance of experimentation and testing to produce visionary architectures in different temporalities from Leonardo da Vinci to Buckminster Fuller. She states that experimentation is crucial in developing new ideas whether they are realised or not. In short, it can be said that experimenting is a driving force for visionary architecture in search of new meanings. Since experimenting attempts to present a solution or statement that does not exist at the time the experiment is conducted, it often challenges with the unknown.

Experimenting with the unknown allows conventional spaces to be viewed from a new point of view. This perspective triggers the

dynamics of transformation; spaces constructed from the unusual break down acceptances and establish another world of curiosity. It can be said that architecture which is often called visionary is exactly the spaces that destroy these acceptances and write new stories by challenging their time - such as; Walking City, which rejects the technological reality of its time with its mega structures consisting of telescopic arms and legs, and the concept of borders with the movement of cities and their users; Nakagin Capsule Tower, which is designed to be mobile and dynamic by opposing the rigid perception of the city and everyday life with its capsules that can rotate around a body and can be dismantled and replaced when necessary; Parc de la Villette, which is incompatible with the main principles of historical composition, hierarchy and order in architecture and the image of the 19th century inner-city park. Forgetting acceptances have helped to build visionary architectures in these projects. Their imagined worlds of curiosity are still considered timeless as they are both relevant to the present and refer to the future. Their visionary nature puts them in a context where they lack an expiration date. But at this moment, it is essential to remember that history is based on acceptances. If all these narratives and projects are perceived as an acceptance and then forgotten, what visionary stories and architectures might have been overlooked or left in the corner? And what acceptances could these visionaries have broken?

*"Architecture's imperative is to grasp something absent, to trace or demarcate a condition that is there only latently."* (Hays, 2015).

Hays defines the task of architecture as the detection and determination of implicit situations and boundaries: in other words, grasping the unknown. It can be said that the concept of visionary is parallel to Hays' architecture since it tries to destroy the acceptances, to grasp and reveal the unknown. When Walking City and Nakagin Capsule Tower are examined in this context, it seems that they

both have defied and forgotten similar architectural norms and acceptances: stability, settlement and daily life. The projects have responded to the unknown in different ways. Walking City, a combination of animal and mineral, has the powerful appearance of a mechanical elephant walking on sturdy legs in the landscape of the city. Its drawing implies that an adventurous and nomadic life is lived in the giant rotund form. On the other hand, Nakagin Capsule Tower, based on the concept of a helix, has a quality of movement that expresses the theme of change. It serves the fast and dynamic city life with plug-in units (Goodman, 2008).

These projects, where the relationships between forgetting acceptances and visionary architectures begin to be deciphered, can also be defined as avant-garde. Avant-garde, which entered the political language as a military term in 1830-40, has been associated with modernism, society, politics and art over the years. It goes through periods where it fades and flares up, burns out and revives as neo-avant-garde (Artun, 2003). Due to the time constraint that avant-garde has etymologically, the concept of visionary referring to a long historical past has been used in this study. Throughout the history of architecture; encompassing a timeline from the architecture of primitive ages to the utopias of Renaissance; or from the 20th century Constructivists to the Situationists and Deconstructivists; a great number of moments of crisis generated creative productions that later came to be theorised as avant-garde, experimental, critical, non-standard and many more within the main title of "visionary". Yet, visionary architectural productions are still being generated in the crisis of the contemporary architectural milieu of today. One of the biggest supporters of this emergence of the visionary is technological development which provides space, materials and incentives for new experiments. Therefore, this study aims to trace the visionary architectures of the 21st century and has two main

focuses: crisis and Cloud 9. First, it tries to reveal the relationship between moments of crisis and the act of forgetting acceptances and experimenting. Then, it focuses on the architecture of Cloud 9, which conceptualises crisis as the basic philosophy of its architecture. As a result, it tries to decipher which acceptances in Cloud 9 architecture are destroyed by moments of crisis and their relationship with visionary formation.

**Crisis** *"blurring of boundaries that separate the object from its surroundings"*

Moore states that the common purpose of art and science is to overcome chaos. The scientist uses the pieces of chaos that her/his intuition guides her/him in order to detect a model of order. Then, using her/his creative hunches and perspective, s/he tries to relate the model s/he finds to other patterns of order (Moore, 1965). Chaos, which focuses on phenomena that depend on many parameters and factors, seems to have potential for science. Considering the relationship between architecture and science may involve questioning the similarity of chaos to moments of crisis. Because as science tries to overcome chaos, architecture can also perceive crisis as a productive potential that establishes its conceptual narrative.

Petit (2005) mentions that crisis benefits the executive power in the political realm because crises cause action without the need for legal instruments. In this context, he likens the concept of crisis in architecture to the executive power and draws attention to the fact that architects love crises because the productivity of crisis lies in their potential to structure conceptual frameworks. So much so that Tafuri and his critical Marxist friends also have a positive perspective on the concept of crisis. Tafuri (1990) has no doubt that crisis will ultimately be productive; because, instead of petrifying only those within the boundaries of an ideology, it has the potential to multiply our views on history, language and origins. In his eyes, crisis is a productive and



Fig.1 – Image related to forgetting acceptances in architecture (Pinar Akin, 2024).



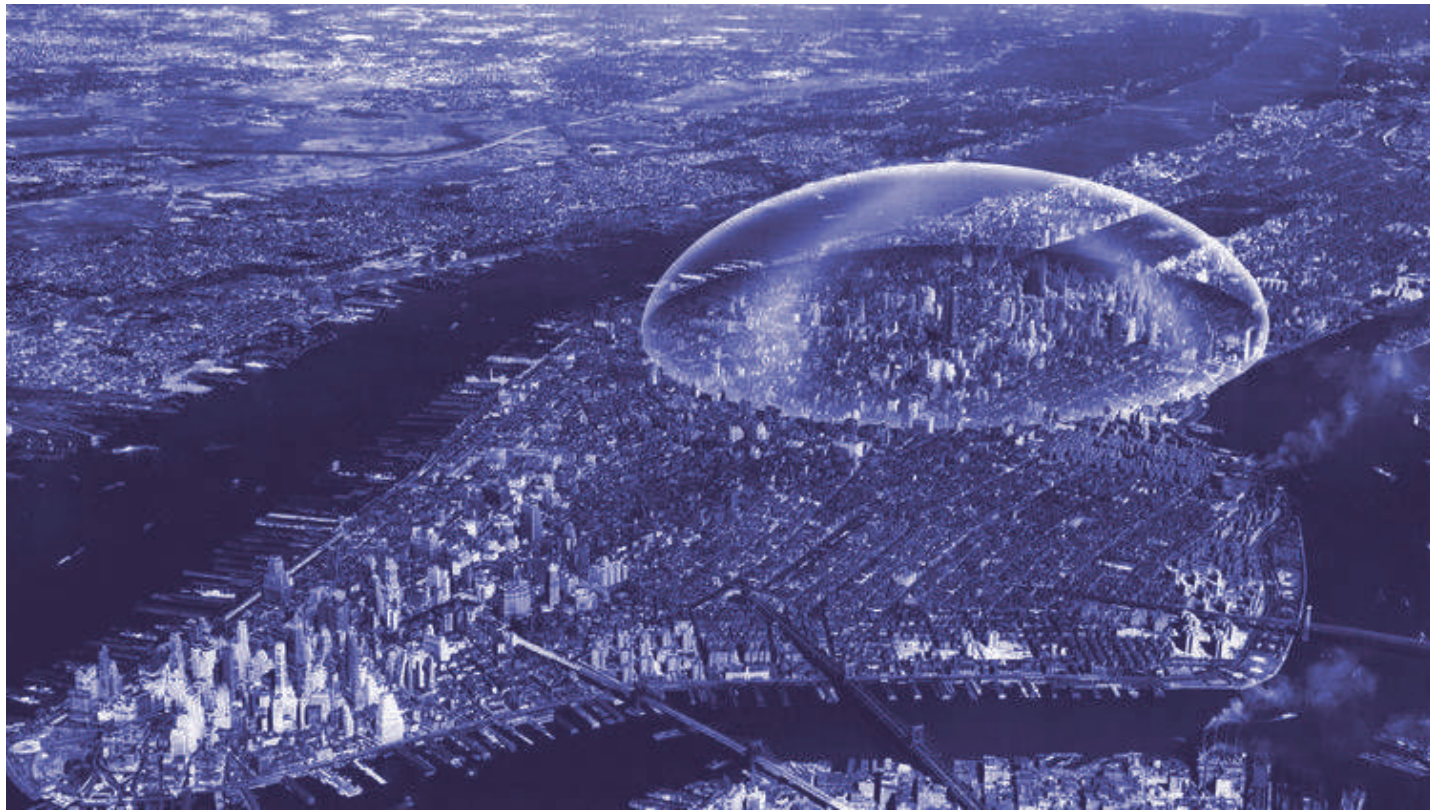

Fig.2 - The dome over Manhattan. <https://seyley.ekstat.com/img/max/800/o/oRUx19TfctnEAUrC-637220250822398661.jpg>, date accessed 08.11.2024

projective tool.

Moments of crisis are times when the extraordinary can occur and when existing acceptances and rules for coping do not work, and attempts at new solutions are made. As Hays (2015) states, it is an effort "to grasp something absent". Philosopher Husserl, who showed a very comprehensive interest in the philosophical crisis of Europe, says that the crisis which started in the 19th century was related to the meaning of science being considered as purely scientific. In other words, the fact that science can be equated with the meaning of human existence was ignored and the questioning of what the progress of science meant for life and humanity was forgotten. Historically, with the two world wars that occurred in the 20th century, this crisis turned into a general state of anxiety (Hoşgör, 2020). So, where does visionary architecture stand in these moments of crisis and how does it question what it means for life and humanity?

The experimental works that construct visionary architecture have been influenced by science as much as they have been

nourished by philosophy. In the early 20th century, science, mostly mathematics, was seen as an inevitable tool for being modern. Therefore, science played an important role in some modern theories. For example, Le Corbusier's debt to scientific theory is associated with mathematics due to the importance he gave to the golden ratio and the golden number. Supporting this fact, Loach (2018) says that Corbusier's relation with scientific thought was shaped by the field of psychophysics as much as mathematics, and even more so. Le Corbusier, who left a remarkable impact on the modernist movement by reflecting scientific advances in his architecture, can be a potential starting point to discuss the relationship between science and visionary architecture. Visionary architecture is intertwined with science both because it creates a conceptual framework by being influenced by various fields of science and because it incorporates scientific developments into research and practice.

One of the most striking examples of architecture's efforts to cope with moments of crisis with the help

of science is Buckminster Fuller's proposal to build a giant geodesic dome over midtown Manhattan in 1960 (Fig.2). The dome large enough to cover a significant part of the city was intended to reduce air pollution and regulate the air. Thus, no one would have to heat or cool their apartment because the entire dome would be kept at a comfortable temperature. According to Fuller, the cost of the dome would be equivalent to the cost of clearing the city of snow for ten years.

Petit (2005) sees a similarity and parallelism between the crisis of liberation from normativity in the modern architecture of the seventies and the midlife crisis in human psychology. Architecture is experiencing a midlife crisis. Because it is in a period of emotional turmoil, depicted by a strong desire for change. Fuller's geodesic dome, one of the manifestations of the desire for change, draws a sharp, albeit transparent, boundary between itself and the crisis. The Dome's way to cope with the crisis is to distance itself from the crisis as much as possible. But if the opposite is considered, can the boundaries that separate the architectural object

from its surroundings become blurred in moments of crisis? In which implicit narratives of the 21st century can we encounter this blurring?

It would not be wrong to say that moments of crisis are mostly related to ecology in the 21st century. Fernandez et al (2012) draw attention to the fact that ecology has been an important factor to be taken into consideration in recent years. This situation has become an opportunity to find new solutions by forgetting old and accepted models which are invalid. In this context, the integration of parametric design tools into architecture offers a great potential not only for form making but also for new spatial possibilities related to the processes of energy flows. In their article where they touch upon projects that approach optimization as an ecological challenge, Fernandez et al include two projects designed by Cloud 9, which this study also discusses. Focusing on the global warming scenario, Cloud 9 and the founder of the team, Enric Ruiz Geli, become a relevant context to discuss the productivity of crisis.

#### Particle theory "material and non-material information"

In his interview with WIA (2021), which interviews the world's leading architectural designers and thinkers, Enric Ruiz Geli opens up the question of "What



Fig.3 - Architecture of particles. <https://www.ruiz-geli.com/media/particles/el-bulli/03-Enric-Ferran-particulas.jpg>, date accessed 08.11.2024

is architecture?" by examining the answer given by theatre and cinema director Peter Stephen Paul Brook to the question "What is theatre?". According to Brook, theatre is a breath of fresh air between the audience and stage design, that is, a dialogue between the audience and the stage. In this context, the best actor is the best listener. Ruiz Geli, on the other hand, says that architecture is about particles after silently listening to the question of "What is architecture?" (Fig.3-4). From his perspective, if the building listens to the tree, the tree is strong enough to tell it what to do. Ruiz Geli focuses on the fact that urban planners and architects can be both the cause and the solution of today's crisis - global warming. Because buildings also have the potential to produce the energy they will expend, according to him, it is possible to be a positive hacker by staying within the system, just like Tim Burton's Edward Scissorhands. If architects who turn their position as positive hackers to crisis succeed, they will be known as social activist architects, he says.

Ruiz Geli, who discusses his definition of architecture through theatre, worked on stage design for a while during his university education. That is why his architecture team Cloud 9 may bring together people from many different disciplines: theatre director, theorist, philosopher,

artist, visual artist, scientist, ceramicist, designer, educator, sculpture designer, sound environment musician, architect, landscape architect, fashion designer, photographer, economist, chef. Cloud 9 presented its particle theory at the Venice Biennale in 2012.

This thesis interprets reality at the level of particles and designs strategies for both tectonic or material and climatic or immaterial elements. It records the landscape as particles using 3D laser scanning technologies, point cloud files that can be managed with 3D software and sensors installed on location. For this reason, particle theory does not distinguish between product and object, landscape and building, mountain and sea; it interprets the architectural project as performing particles (Url-4).

Focusing on global warming scenarios, Cloud 9 aims to destroy the sharp boundaries between the architectural object and its surroundings in times of crisis thanks to the particle theory. This boundary begins to dissolve both with the change and transformation that the architectural object undergoes with environmental data and with its stance against the system without separating itself from the system. Scientific developments are used for the practice of recording and



Fig.4 - Architecture of particles. [https://www.ruiz-geli.com/media/particles/empathic\\_particle\\_tree.jpg](https://www.ruiz-geli.com/media/particles/empathic_particle_tree.jpg), date accessed 08.11.2024





Fig.5 – Villa Nurbs. [https://lh5.googleusercontent.com/-aza\\_bM5PKXE/TuiLYGKo1ZI/AAAAAAAAABMw/9Fo4lW6g3q0/s0/VillaNurbs18.jpg](https://lh5.googleusercontent.com/-aza_bM5PKXE/TuiLYGKo1ZI/AAAAAAAAABMw/9Fo4lW6g3q0/s0/VillaNurbs18.jpg), date accessed 08.11.2024

reproducing environmental data and designing strategies. Thus, the non-existent becomes testable and doable. These experimental studies advance the team's architectural practice on the path to becoming visionary. So much so that Cloud 9 earns most of its income not by constructing buildings but by producing patents that it shares with a small group of investor customers.

#### Experimental research "testing unconventional ideas"

Testing unconventional ideas is one of the most important elements that shapes Ruiz Geli's identity as an architect. That is why projects where he can conduct experimental research, primarily competitions, attract his attention. He bases his architectural practice on a system that he tries to open up through the tension between space, material, technology, science and society. For him, it is important to take action and be an activist in order to realise change.

For Ruiz Geli, the first scale to be tackled in architecture is the house. In this context, he addresses the green roof as both an architectural element that provides thermal insulation and an initiative that offers new biodiversity to its surroundings in his project called Villa Bio. Villa Nurbs, on the other hand, carries the house research to a deeper and more exciting point as developing a new system for not only the roof but also the entire house. The story of Villa Nurbs begins like this; one day, Ruiz Geli's mother's friends ask him to design a new house. The architect, who is more interested in competitions, hopes to dissuade the customers from the project by asking which of the photos of melting ice blocks they want as a house. However, the customers point to a group of ice lumps, and this creates an opportunity for the architect (McGuirk, 2011). Because for Ruiz Geli, an interface is created where he can use the concept of house as an experimental laboratory.

McGuirk (2011) states that the

introverted house is reminiscent of Frederick Kiesler's Infinite House; a fluid space trapped inside an egg (Fig.5). The interior space works as a whole, the doors and parts are not separated from each other. Rising on a concrete base, the house becomes lighter as it moves towards the roof made of ETFE cushions. The facade is made of ceramic, glass, ETFE and Corian, which is related to the actions inside and the atmosphere outside. Ceramic plates resembling a wave form protect the house from strong sunlight. The roof is made of inflatable plastic bubbles that save energy. The motors of the machines in the house are connected to a solar-powered shed in the garden via underground pipes. Therefore, there are no light switches in the house, only sensors.

Designed as an ecological and futuristic house, Villa Nurbs resembles a monster with its appearance. The villa, which has become a cult object by attracting attention because of its difference, has become a stopping point for

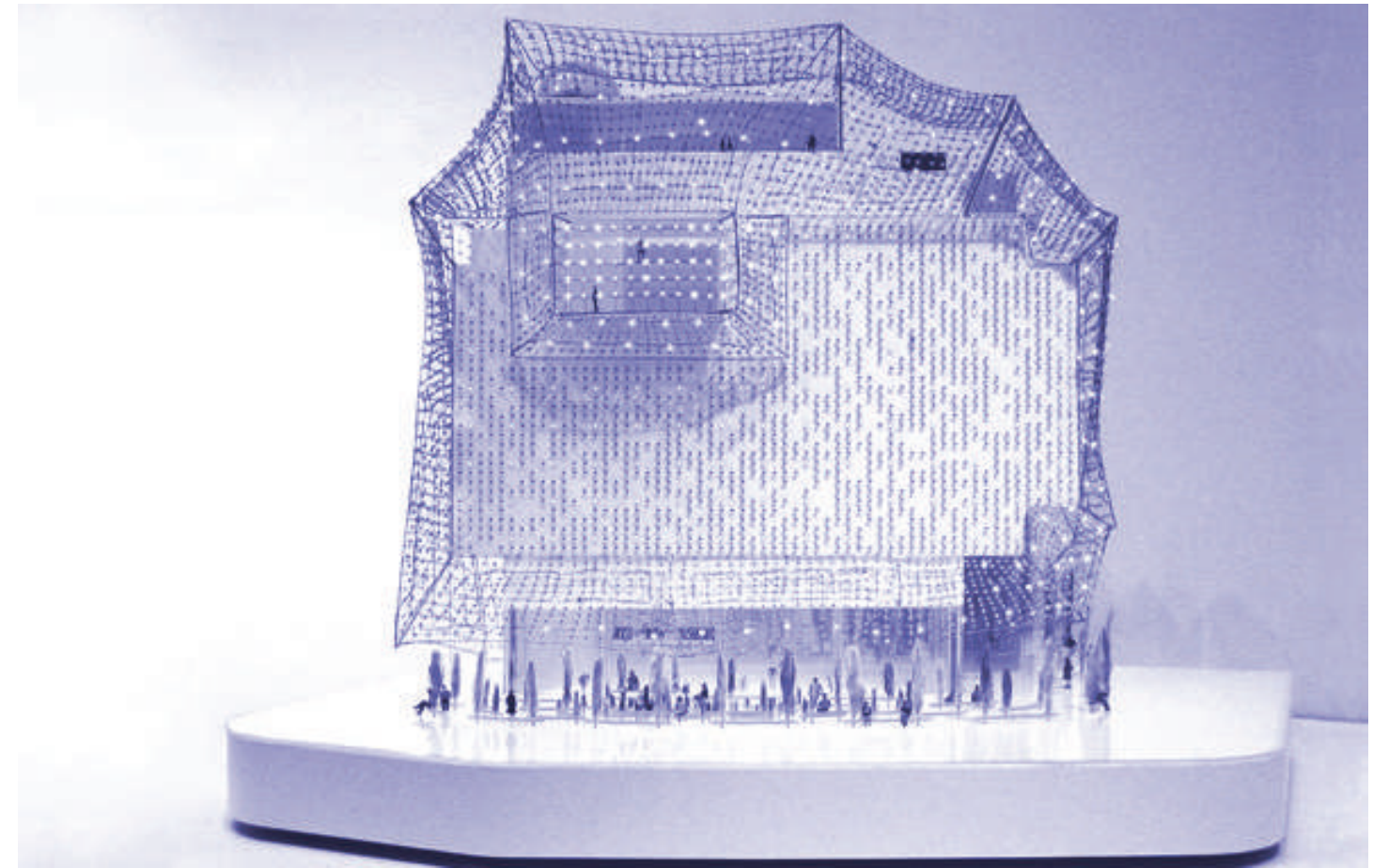

Fig.6 – Forest Hotel. [https://lh5.googleusercontent.com/-mpYvDSC\\_vmA/TuX2Tvad7LI/AAAAAAAAAuA/oCX4qn3Aons/s0/Cloud9\\_23\\_forest.jpg](https://lh5.googleusercontent.com/-mpYvDSC_vmA/TuX2Tvad7LI/AAAAAAAAAuA/oCX4qn3Aons/s0/Cloud9_23_forest.jpg), date accessed 08.11.2024

architects such as Winy Maas, Kengo Kuma and Bjarke Ingels while passing through Barcelona. The windows of the digital house, each part of which was specially designed, took two years to produce, and the glass walls were broken several times before being installed. Therefore, although most of the project is complete, it is still under construction because unexpected situations that develop during the process are an inevitable part of being experimental and reaching the unknown.

Villa Nurbs conducts its experimental research within its own area surrounded by high walls and the house is closed to the city and its residents. However, a different structure with a similar logic to the system developed by Cloud 9 for the house establishes a new relationship with the city through a hotel project designed by the team: Forest Hotel. The unique aspect of the project is its facade, which goes beyond traditional norms. It both produces and consumes energy by utilising solar

energy like the leaves of a plant. The facade is a system consisting of light-emitting modules suspended on a steel mesh. One side of the modules is made of translucent plastic, the other side is made of transparent glass. Each disk contains a photovoltaic cell, light sensor, battery and RGB led source. Thus, the facade, which has the capacity to react and respond to the urban context, becomes a dynamic part of the landscape (Gerfen, 2008). The 1/50 scale model of the project was purchased to be exhibited in the "Dreamland: Architectural Experiments since the 1970's" MoMA exhibition (Fig.6).

#### Urban lab "connectivity, new materials and nanotechnology"

Ruiz Geli emphasizes that architecture should be a technological platform in the digital information age. Connectivity, new materials and nanotechnology are important for the creation of this platform. Therefore, when a public competition was held for the Media-ICT project, Cloud 9 participated in

the competition, considering that the building to be designed was in line with their own knowledge. They were very interested in a digital city model focused on ICT (information and communication technology), where knowledge, added value and patents are important. Media-ICT emerged after other projects of the team, such as Villa Nurbs and Forest Hotel, which included digital production processes, ubiquitous technology, cloud computing, off-grid energy and distributed intelligence concepts (Url-4).

Media-ICT is located in 22@, an urban renewal area in the former industrial district of Poblenou, Barcelona. 22@ is an experimental area that does not rely on the availability of natural resources such as water, oil and gas. It focuses on technology and innovation; it does not include real estate values in the equation. The identity of the area coincides with the architectural philosophy of Ruiz Geli and Cloud 9. Cloud 9 designed Media-ICT on the idea of sharing. The structure, which allocates a significant part of





Fig.7 – Media-ICT, [https://lh6.googleusercontent.com/xgpypltdlxw/Tt9XuUk9b8I/AAAAAAAAAT0/9NAybaYdO4/s800/024Media-ICT\\_Cloud9.jpg](https://lh6.googleusercontent.com/xgpypltdlxw/Tt9XuUk9b8I/AAAAAAAAAT0/9NAybaYdO4/s800/024Media-ICT_Cloud9.jpg), date accessed 08.11.2024

it to common areas, tries to create a sense of dialogue with the city by opening up to the outside (Fig.7). It includes public spaces in the building by avoiding the columns on the ground floor as much as possible. It establishes this system with a network-like steel structure, and the elements of this structure are not standard.

The façade of the building consists of inflatable ETFE cushions that can be oriented towards the south. When the temperature increases, these cushions inflate and provide thermal insulation and opacity with the air chamber inside, and act as a variable sunscreen. They open in the winter to obtain solar energy and close in the summer for protection and shading. On the

southwest façade of the building, nitrogen-based fog is applied to the cushions. Thus, it increases its particles and provides more opacity and protects its users. The operation of this complex system depends on more than five hundred sensors. Multiple temperature, humidity and pressure sensors that collect external information allow the adjustment of internal conditions. In short, the building's system is designed to be a generator that optimises energy use, unlike most buildings that consume large amounts of energy. Thus, Media-ICT targets a total carbon dioxide reduction of 95% (Url-4).

**Becoming visionary** “forgetting acceptances and the productivity of

Groat (2000) suggests that of the architect as a cultivator of a larger communal mission of well-being instead of two traditional images of the architect as a technician or an artist. From her proposed paradigm, the architect as a cultivator embraces three things: participatory and collaborative spirit, interdisciplinary study and a sensitivity for the cultural as the soul of design. The concept of cultivator, which embraces these three matters, coincides with Cloud 9 architecture and the state of being a positive hacker in the words of Enric Ruiz Geli. Because Cloud 9, which focuses on moments of crisis, tries to present a sensitive architecture with participatory and

interdisciplinary processes. In short, Groat's concept of the cultivator seems to correspond to the visionary becoming in this study.

The purpose of this research is to open up for discussion the set of values brought by the moments of crisis through the non-standard systems of Cloud 9, to understand which acceptances were deviated from in architecture through this set, and to bring an opening to the notion of visionary architecture by deciphering the relations before and after the crisis. So, it may be more accurate to define the projects in the research as performative systems rather than buildings or structures because they provide a new perspective that changes and transforms environmental data in a material and immaterial way rather than creating a fixed formation and image.

Cloud 9 addresses global warming as a moment of crisis. Compared to industry and deforestation, the most fundamental cause of global warming is energy use: coal, oil and natural gas. An architect concerned with the production and consumption of energy develops the systems s/ he designs in this direction. This process is mostly intertwined with science in terms of operation and as a tool. Cloud 9 also aims to produce consistent information and systems by using a number of methods and experiments, and in this production, the team benefits from the opportunities provided by technology such as laser scanning, point cloud files and sensors installed on the location. As can be seen from the systems examined in the research, each one is unique and non-standard; because it is the product of a different experimental research carried out in a different laboratory.

The performative systems of Cloud 9 forget many of the acceptances of today's architecture: “fast production”, “standardised construction methods”, “uniform energy schemes”, “solidified materials” and “independence from climatic data”. After the act of forgetting, it designs new concepts

instead: “production in the time required for the experiment to take place”, “construction methods developed specifically for each system”, “energy schemes that work without being connected to the grid”, “materials that change and transform”, and “the system feeding from climatic data”. Although Cloud 9's unique perspective on the concept of crisis has enabled it to go beyond conventional architectural norms, the point that technology has reached is also effective. As Fernandez et al (2012) indicate, forms and systems that have been seen as impossible to create before are now possible with the help of new technologies. Projects such as the Dome over Manhattan or Walking City, which were dreamed of as alternative escapes in times of crisis and were impossible and utopian at the time, are possible today or in the future. That is why it is important to turn the moments of crisis into an opportunity and to experiment a lot while forgetting the current acceptances and looking for the non-existent. Thus, crisis as a productivity tool can lead to visionary architectures. In a word, visionary formations that perceive the set of values brought by moments of crisis as a potential for productivity can reveal the untried, unknown, or inexistence by forgetting the acceptances about architecture. As Spiller (2008) indicates, visionaries teach being passionate and optimistic and not to acknowledge hollowness which are mostly introduced as architecture in the world. This is why visionary architectures are important to explore new spatial and philosophical possibilities.

## ACKNOWLEDGMENT

The outline of this article was prepared in the “Visionary Design and Architecture” PhD course instructed by Prof. Dr. Ayşe Şentürer in Istanbul Technical University, Architectural Design Doctorate Program. I would like to thank Prof. Dr. Ayşe Şentürer for her encouragement and comments. I would also like to thank my colleague Res. Assist. Çağdaş Kaya for his support in the process.

## BIBLIOGRAPHY

ARAUJO, M. P. and others. History, Memory and Forgetting: Political Implications. In: RCCS Annual Review. 2009, 1, n.p. <https://journals.openedition.org/rccsar/157>

ARTUN, A. Kuramda Avangardlar ve Bürger'in Avangard Kuramı. In: BÜRGER, P. Avangard Kuramı. Istanbul: İletişim, 2003, pp. 9-32.

FERNANDEZ, A. and others. Generative Architecture as a methodology of optimisation. In: Less – More Architecture Design Landscape. 2012, pp. 305-314.

GERFEN, K. 2008 R+D Awards: Artificial Leaf. In: Architect. 2008, n.i., n.p. [https://www.architectmagazine.com/awards/r-d-awards/artificial-leaf\\_o](https://www.architectmagazine.com/awards/r-d-awards/artificial-leaf_o)

GOODMAN, Donna. A History of Future. New York: The Monacelli P, 2008.

GROAT, L. A Conceptual Framework for Understanding the Designer's Role: Technician, Artist, or Cultivator? In: KNOX, P., OZLINS, P. Design Professionals and the Built Environment: An Introduction. New York: John Wiley & Sons, 2000, pp. 41-54.

HAYS, Kenneth Michael. Architecture's Desire: Reading the Late Avant-Garde. Cambridge: MIT P, 2009.

HOŞGÖR, K. On Edmund Husserl's Crisis Analysis. In: Beytulhikme An International Journal of Philosophy. 2020, 10(2), pp. 489-509.

LOACH, J. Architecture, science and purity. In: BUD, R., GREENHALGH, P., JAMES, F., SHIACH, M. Being Modern: The Cultural Impact of Science in the Early Twentieth Century. London: UCL P, 2018, pp. 207-244.

MCGUIRK, J. Villa Nurbs by Enric Ruiz-Geli. In: Icon. 2011, n.i., n.p. <https://www.iconeye.com/architecture/villa-nurbs-by-enric-ruiz-geli>

MOORE, C.W. Architecture: Art and Science. In: Journal of Architectural Education (1947-1974). 1965, 19(4), pp. 53-56.

PETIT, E. The Midlife Crisis of Architecture: A Theory of the Creative Leap. In: Thresholds. 2005, 29, pp. 38-43.

SPILLER, Neil. Visionary Architecture: Blueprints of the Modern Imagination. London: Thames & Hudson, 2008.

TAFURI, M. The Sphere and the Labyrinth: Avant-Gardes and Architecture from Piranesi to the 1970s. Cambridge & London: MIT P, 1990.

WIA. Cloud 9, Enric Ruiz Geli: What is architecture? [Video]. YouTube, 2021. <https://www.youtube.com/watch?v=vBSBzsfLkCA&t=27s>



**ARCHITECTURE,  
URBAN PLANNING  
AND ART**



# The Radicality of Use

Practices of transformation based on the occupation and appropriation of buildings

reutilizar  
lugar  
interacción  
temporalidad  
reprogramación  
**reuse**  
**place**  
**interaction**  
**temporality**  
**reprogramming**

La intención de este artículo es plantear la radicalidad en la arquitectura contemporánea a través del análisis de prácticas de transformación espacial basadas en el uso y observadas en la ocupación y la apropiación colectiva de edificios en desuso. En contraposición de la arquitectura tradicional, que se apoya en herramientas de representación abstractas y preconfiguradas, estas tácticas emergen como respuestas espontáneas de abajo hacia arriba, reflejando la efectividad de las prácticas grupales en la reprogramación de espacios. Utilizando una metodología cualitativa basada en la observación directa, entrevistas con los participantes y el análisis de documentos, se examinan tres casos europeos de ocupación donde se identifican prácticas de transformación del espacio a partir del uso. El éxito en los resultados de estas intervenciones demuestran que hoy en día la ocupación y apropiación se utilizan positivamente como un medio para aprovechar los recursos infrautilizados y alterar el statu quo. Son las propias prácticas las que se vuelven una herramienta con la cual cuestionar el espacio normativo predeterminado, evidenciando una espacialidad surgida desde las bases, y reafirmando el campo social y la identidad de grupo como generadores de lugar. Centradas en la experiencia y la vivencialidad, las prácticas de cada grupo específico modifican el espacio y lo reprograman sin grandes intervenciones materiales, obligando a incluir las dimensiones sociales y simbólicas cuando analizamos la transformación sobre el objeto. A partir de las evidencias, se observa la radicalidad de las diferentes producciones espaciales, demostrando la vigencia del uso y las prácticas como medios alternativos de hacer arquitectura.

The purpose of this article is to explore radicalism in contemporary architecture through an analysis of space transformation practices grounded in the use of space, particularly observed in the collective occupation and appropriation of disused buildings. Unlike traditional architecture, which relies on abstract, preconfigured representational tools, these tactics emerge as spontaneous, bottom-up approaches, highlighting the effectiveness of group actions in the reprogramming of spaces. Adopting a qualitative methodology that includes direct observation, participant interviews, and document analysis, this study examines three European cases of building occupation, where the transformation of space is driven by its active use. The success of these interventions demonstrates that occupation and appropriation are now being utilised as positive tactics to repurpose underutilised resources and challenge the established spatial order. These approaches become tools for questioning predetermined normative spaces while reaffirming social dynamics and group identity as fundamental in the process of making Place. By focusing on experience and presence, these social groups' efforts transform and reprogramme spaces without requiring significant material interventions, compelling the inclusion of social and symbolic dimensions in the analysis of spatial transformation. The evidence highlights the radical condition of these space productions, demonstrating the continued relevance of use and practices as an alternative means of making architecture.

**Cardini, Roberto Juan<sup>1</sup>**

<sup>1</sup> U.P.M., D.P.A., E.T.S.A.M, Madrid, Spain.  
<https://orcid.org/0009-0002-6342-8517>  
rjcardini@gmail.com

Citation: Cardini, R. (2024). "The radicality of use", UOU scientific journal #08, 104-115.

ISSN: 2697-1518. <https://doi.org/10.14198/UOU.2024.8.11>  
This document is under a Creative Commons Attribution 4.0 International license (CC BY 4.0)

Article Received: 14/09/2024  
Received in revised form: 01/10/2024  
Accepted: 11/11/2024





## INTRODUCTION

In the late 1960s, leisure, knowledge (*connaissance*), and art were largely uncontrolled spaces, serving as focal points for the radical practices of that era (Lefebvre 1978). In contemporary times, however, these sectors are experiencing accelerated institutionalisation, shaping even the most intimate and routine spaces through prefigured configurations derived from abstract, instrumental representational tools. The resources and tools employed by architectural disciplines to represent these spaces are increasingly distanced from the experiential and participatory practices of individuals.

A radical resource for re-establishing this relationship is to revalorise 'use' as a mechanism for spatial transformation. This process occurs both organically and explicitly in the occupation and

appropriation of buildings, where social practices are not merely an additional variable but are instead the primary force in making Place, even supporting the reproduction of these very practices (Giddens 1984, Abu-Lughod 1968). In the reuse of a building designed for a specific function, radicality is generated through the disruption of determinism achieved by the practical transformations involved in reprogramming. This transformation is not only material; it additionally marks a fundamental shift within social and symbolic dimensions. Today, practices of occupation and appropriation are a positive means of utilising underused resources and challenging the status quo. These practices serve as tools for questioning normative, predetermined spaces, enabling the creation of new activities and, in most cases, providing collective spaces for the community.

## OBJECTIVES AND METHODOLOGIES

The aim of this work is to define radicality in architecture by identifying differentiated transformative practices observed in the use of space. This study focuses on contemporary active examples, analysing three European cases where reprogramming for cultural purposes has been successfully achieved through occupation and appropriation.

With the premise of using case studies as an opportunity to empirically demonstrate certain theoretical concepts or principles (Yin 2017), three cases were selected after an initial assessment of fifty European cases of collective reprogramming. An XY Cartesian coordinate system (Fig.1) was used, with the horizontal axis representing the degree and type of intervention and the vertical axis representing the form of occupation. The characteristics and relevance of each case were then systematically evaluated. These cases were intentionally selected to represent different forms of intervention within various dynamics of occupation (as reflected in the diagram), while observing common effects and transformations.

Three cases were chosen because the research is structured on a logic of replication within a multiple-case study approach. In this way, each individual case becomes the subject of a full case study, where convergent evidence is sought to support the study's findings and conclusions. Furthermore, the case selection is justified by data repetition across different developmental models in different countries within the same region, each with diverse processes and outcomes. This variation in development aids in observing and comparing replication in different contexts, allowing for the recognition, a priori, of constants present in cases that are structurally similar but empirically diverse (Yin 2017).

selection of these three definitive cases is their relevance as activity catalysts, that is, their success as case studies. Cases chosen for in-depth analysis had to be reference points in their field of expression, reaching certain momentum within their groups, transformations, and the spatial identity produced. This factor demonstrates the value and relevance of transformations achieved through use.

Consequently, through this case selection, I illustrate the transformations emerging from collective use in the process of occupation, which I consider to constitute contemporary radicality in architecture. This article enumerates and contrasts the elements distinguishing this radicality from predominant disciplinary architecture, highlighting alternative processes for generating Place and spatial identity.

The cases analysed are:

**Mercato Sonato. Bologna, Italy.** A neighbourhood market built in the 1950s that, thanks to the temporary occupation by a symphony orchestra, became one of Bologna's most important cultural centres dedicated to music, with a primary school of 400 students and over 8,000 members. The building is undergoing demolition.

**Plantage Dok. Amsterdam, Netherlands.** A squat from 1998 that, through an assembly-based horizontal structure, managed to transform an old printing house, built over a Reformed church, into a building with residential units, artists' studios, and a cultural centre. It is a landmark case of a collective squad that managed to purchase the building and transform it into a Place representative of its own practices.

**Wagenhallen. Stuttgart, Germany.** A case of a railway carriage workshop that was reprogrammed by a group of artists into studios, housing, workshops, and a communal space. Due to the success of the temporary occupation and the ongoing transformation process driven

by practices, the building was converted into an artists' workshops and a significant cultural site in constant growth.

The purpose of this article, based on an empirical study of these three cases and supported by theory, is to identify spatial transformation practices arising from use, while contrasting them with institutional and hegemonic practices.

This research was conducted through a qualitative approach, centred on direct observation of the cases, participant interviews, and document analysis. A total of fourteen interviews were carried out with key individuals involved in the three spaces, alongside an analysis of one hundred and fifty documents, including photographs, architectural plans, articles, and press interviews, and finally, forty hours of observational study. Based on this evidence, several practices have been identified that stand in contrast to the generic approach to architecture. Radicality is proposed here as an alternative to traditional architecture, emphasising the importance of social practice and temporality in spatial transformation. This approach to architecture can create an architectural footprint expressed through reprogramming and the use of space, rather than relying solely on material interventions.

## STATE OF THE ART

**Occupation - Reusing vs. Building (Context).**

If there is a position that challenges architectural tradition, it is the decision not to build at all. Reusing an existing space, instead of constructing a new one, is a subversive act against the dominant economic approach in architecture. Nevertheless, the reuse and reprogramming of existing buildings have notable historical precedents.

Not too far back in time, the political and social events of May '68 inspired activists and architects to explore potential tactics for occupying and appropriating buildings as well as urban space. These radical practices, set in

opposition to the political and economic model of the time, centred on a critique of modernist architecture, which not only championed functionality and aesthetic composition but also bolstered social discipline, facilitating, and experimenting the city's transformation processes, both in terms of policy planning and civic governance and design<sup>1</sup>.

Within this context, radical concepts emerged, such as Price's anti-building, Tschumi's misuse, or Lefebvre's *détournement*, all of which revalued action and social practice as central components of architecture, shifting the focus away from the formal and material.

These critical practices not only established a political, social, and activist vision of architecture but also progressively legitimised everyday use as an essential component of spatial transformation and appropriation, which ceased to be designed for a specific, predetermined function. While developments like 'Learning from Las Vegas' revealed a spectacular renewal of architecture's historical association with graphic and sculptural arts, emphasising symbol over space (Anderson 2016, 33), social practices slowly began to emerge as dissident expressions within an increasingly exclusionary and superficial system. Dissent and radicalism grew in parallel with rising inequalities. What initially appeared to be an alternative to the modern movement instead became a space that simulated freedom and emancipation through the illusory power of image and consumer satisfaction. In doing so, it ultimately reinforced the reproduction of a new phase of multinational capitalism<sup>2</sup> In practical terms, as industrial cities in Europe transformed into post-industrial centres in the 1970s and 80s, occupying disused buildings became a subversive tactic.

This approach addressed housing shortages, created cultural spaces, and highlighted the inequalities emerging from the global economic system. On the one hand, areas with

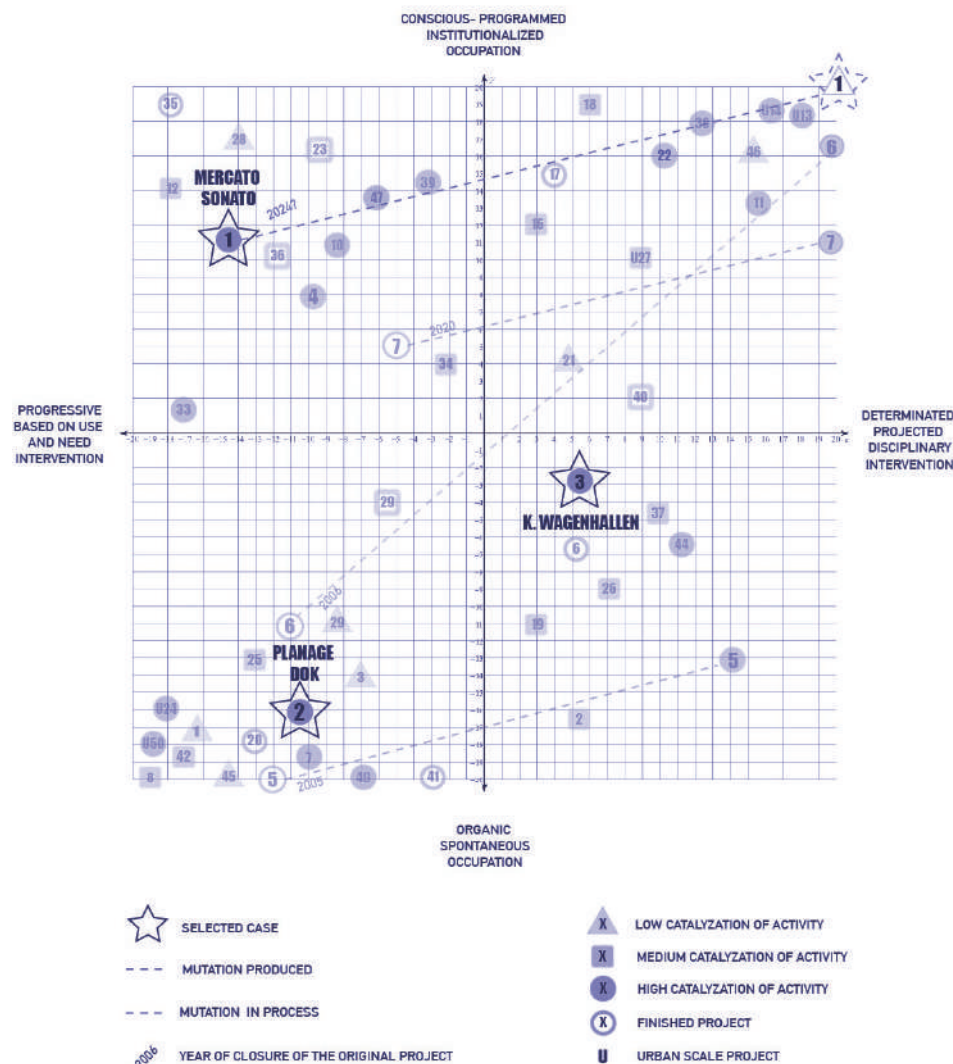

Fig.1 - Cartesian axis diagram for case analysis created by the author.

Finally, another key factor in the



high demand and limited vacant spaces emerged; on the other, areas of stagnation and shrinkage developed and disused buildings appeared (Oswalt et al., 2014). As a result, there was an increase in industrial and infrastructure buildings (located historically in central areas of cities shaped by Fordist industrial development) that became obsolete, fell into disuse, and entered into a new social, economic, political, and urban process.

These processes are observed in the three cases of occupation and reprogramming proposed for analysis. Each is located in areas that were once residual - revealing the inherent differences and contradictions of the system - and were appropriated and reprogrammed out of necessity and the reality of social practices. Both Mercato Sonato and Wagenhallen are examples of temporary occupations agreed upon with the city council as part of plans to revitalise degraded areas through reprogramming. The only unauthorised case is Plantage Dok, a 1998 squatted space that, through struggle and organisation, managed to purchase the occupied building.

Proportionate to the increase in systemic exclusions, we observe the development of an alternative spatial practice based on use and need (desires, affections, differences...) rather than on the functions (mathematical, technical...) of modernity or the superficial image of postmodernism (Till 2013). Within this framework, occupation

and appropriation function as bottom-up spatial practices that integrate physical realities, legal and cultural structures, political dimensions, philosophical foundations, and the routines of everyday life. Today, what began as radical utopian theories and was implemented through social struggle is reflected in tangible, effective elements of spatial appropriation. This demonstrates the ongoing relevance of use and social practices as alternative means of creating architecture and community.

## EVIDENCE

### *Interaction - Practice vs. Abstraction (Mercato Sonato)*

Today, the occupation of disused buildings, understood as residual spaces of uncertainty, creates opportunities for interaction and enables self-organising structures that, determined by the occupants, can drive significant spatial changes at small and medium scales (Miessen 2011, 68). When we speak of occupation and appropriation, we understand these practices as part of an active process of material and symbolic spatial transformation through use, interaction, and physical presence. An example of this process is seen in the Mercato Sonato project (Fig.2), a former market in the San Donato neighbourhood of Bologna, which was transformed, through a city council initiative, into one of the city's most important cultural centres for music through collective in-person practices.

The occupation of Mercato Sonato illustrates significant aspects regarding the value of collective presence in space. The building, once disused, was occupied by an established symphony orchestra with a defined identity and organisational structure. This is reflected in the way transformations are organised, where changes occur not through abstract modes of representation but through joint practice itself (Miessen 2011, 102).

The actions carried out by the Senzaspine Orchestra, responsible for the occupation, can be understood within a micro-context. In this context, a set of shared understandings emerges from continuous and pre-existing interactions, providing the cultural foundation for the action that shapes the space (Fine, 2012, 160). Unlike what may occur in a project designed from disciplinary abstraction, Mercato Sonato was transformed by the group's own practices. The empirical experiences gained through the use and development of their activities became the primary resource for shaping a new place. This process involved re-signifying the space through the group's own practices, resulting in a transformation that is primarily symbolic and social, rather than material. Material changes are mostly seen in the organisation of technical supports such as lighting, sound, stage positioning, storage, dressing rooms, and the division of classrooms for the school. However, the most significant transformation is observed in the change of meaning attributed to

the central space of the market. The space had been converted into a large public square where both the orchestra and the audience gather, as well as a venue for various activities, including meetings for group decision-making. This central space represents the Senzaspine group and, around its centrality, emphasised by the stage and the ability to accommodate the full orchestra, all the secondary spaces are grouped: workshops, kitchen, bar, classrooms, dressing rooms, and storage areas. Collective activity, primarily focused on use, transforms the space in a process that combines the practices and characteristics of the group. These practices, which demand physical presence, stem from the identity of the group, its needs, and its specific variables. In this particular case, it can be observed that the collective structure of the orchestra (divided into groups by instrument type, coordinated by a conductor) is mirrored in the general coordination system of the space. Beyond each band member having value and a vote, the overall direction and coordination is led by a central figure (Fig.3) who holds the baton and organises the collective desires, which are defined by different musical sectors.

In the area, the building was always recognised as the local market. However, since the Senzaspine occupation, the space has been transformed into a public space of music. The central space, which once housed market stalls, was transformed into a centre for various activities. Here, the space hosted concerts, neighbourhood assemblies, and art exhibitions, as well as music workshops and classes.

In the Mercato Sonato project, all material transformations were carried out by the group themselves, based on the specific needs of their activities, on demand. The main hall, the largest space, served as a large theatre with the stage at the back of the building. The need for an administration and management area, as well as storage and classrooms, required smaller and more enclosed spaces.



Fig.3 – Senzaspine band inside the central space of Mercato Sonato on 2nd June 2024 – Source: Photo by the author (2024).

All the open stalls along the perimeter were adapted with light partitions to segregate them as needed (Fig.4).

Until recently, the Senzaspine Orchestra had around 500 musicians, a music school with about 400 children, and 8,500 affiliates<sup>3</sup>. Through their agency and by means of a non-designed space, they managed to revitalise an abandoned building and bring together the culture of music in Bologna at the neighbourhood scale. In this particular case, the level of appropriation and spatial identity generated demonstrates that continuous group relations, enhanced through occupation, sustain collective effectiveness in space transformation practices, without the need for prior design or predetermined structure.

What is unique about this case is that the effectiveness and value of the occupation were so significant that the city council decided to build a new project with the same cultural programme, but by completely demolishing the existing one. This time, the process is antagonistic: a tabula rasa and a predetermined design that does not take into account the previous occupation<sup>4</sup>. The case of Mercato Sonato is, therefore, significant for observing these two opposing processes. On the one hand, it reflects the success of an alternative architecture that manages to reprogram an abandoned building through group practices, producing transformations at symbolic and social levels mainly, with almost no relevant material intervention. On the other hand, there is an integral demolition. a building designed

### MERCATO SONATO - BOLOGNA, ITALY.

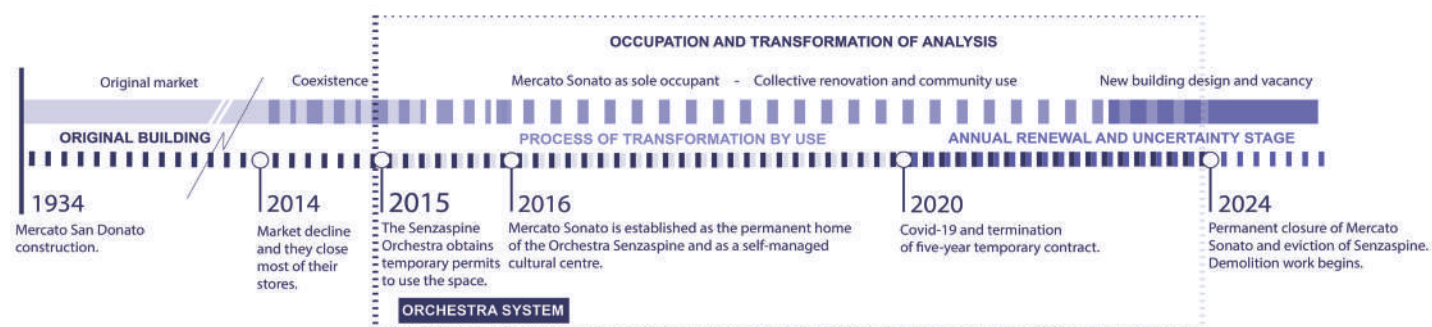

Fig.2 – Temporal development of the spatial process - Timeline by the author.

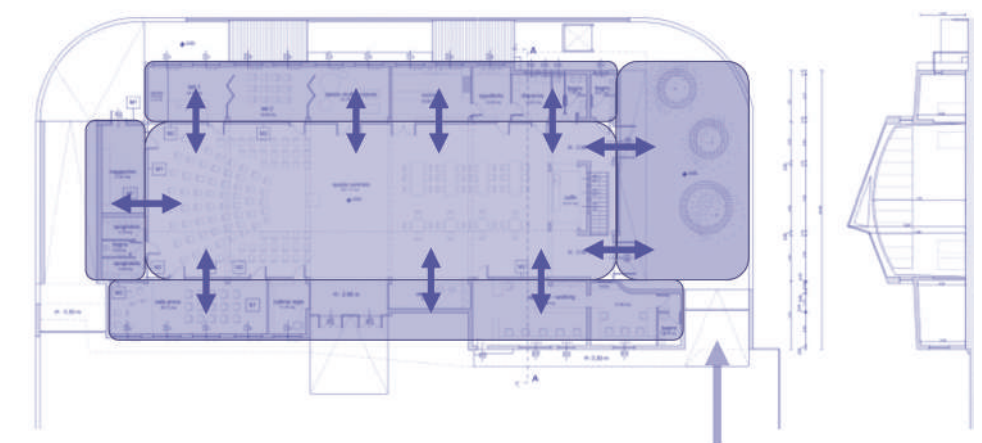

Fig.4 – Floor plan of Mercato Sonato – Source: Tomasso Ussardi Archive - Edited by the author.



## PLANTAGE DOK - AMSTERDAM, NETHERLANDS.

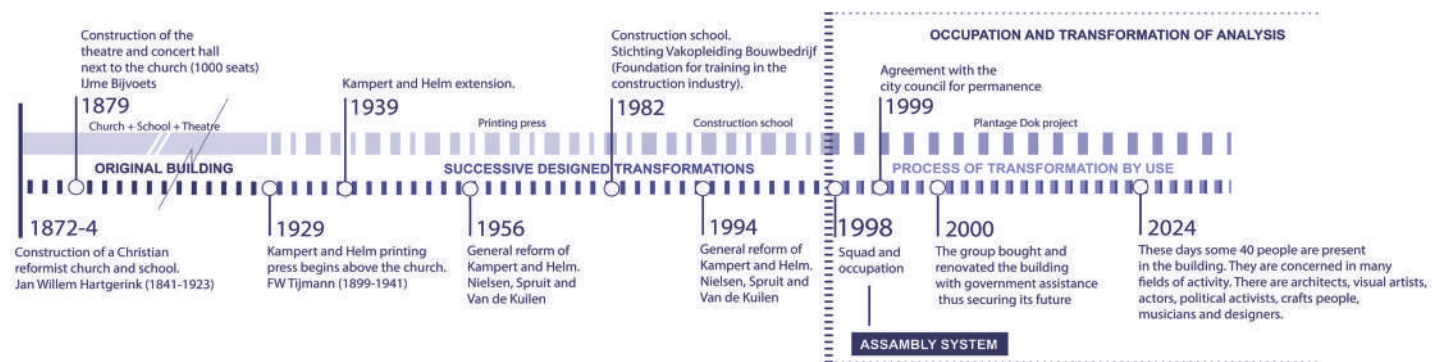

Fig.5 – Temporal development of the spatial process - Timeline by the author.

from scratch that determines and limits the uses of the new spaces by not having the necessary capacities or volumes to accommodate the entire orchestra, nor the audience size that Senzaspine gathered. This shortcoming highlights the lack of observational tools within disciplinary architectural practice.

Mercato Sonato is an example of radical architecture because it demonstrates how to produce Place from the actual use of the building, re-signifying the space through the practices and customs of the orchestra. It constructs space identity as a reflection of the group's identity and organisational system, in contrast to the subjective and biased decisions made through a process of abstraction and subjectivation based on tastes, technical skills, ideas, and external preferences. All the transformations observed in the process of occupying Mercato Sonato were carried out by the group itself according to its actions, uses, and needs, which should now be part of a new identity and occupation process. This is because the original market building no longer exists, and thus, part of it has been destroyed. What remains is the most valuable: the experience of transformation, the radicality of their methods, and the identity built in parallel with the material space.

### Symbolic Transformation - Place vs. Neutral Space (Plantage Dok)

The concept of neutral space is closely associated with the instrumental and technical, due

to its pragmatic and utilitarian nature. As its essence suggests, it refers to a space without distinctive or expressive features. Associating neutrality with a space requires disregarding its political, relational, and social aspects, distancing it from a human-living place. However, this approach is frequently observed within the abstract space that architecture uses as a tool and methodology for production. The outcome of this is the negation of politics within architecture, a biased and partial perspective of space, the exclusion of the social as a key factor, and the detachment of the discipline from the actual needs of use.

As opposed to this view, the occupation and appropriation of space is seen not only as a bottom-

up subversive tactic to break with the architectural disciplinary structure. It is understood as a repositioning and reaffirmation of the field of social practices and group identity as creators of Place, challenging the notion of abstract, neutral space.

If we speak of spatial radicalism, the case of Plantage Dok in Amsterdam, serves as a reference model for organisation and transformation of space, maintaining an assembly system for decision-making since 1998 (Fig.5). The building occupied by Plantage Dok began its history in 1870 with the construction of a reformist church and theatre on two adjacent lots, which over the years have experienced various material and symbolic transformations.



Fig.6 – Photomontage of the main hall at Plantage Dok, formerly the old church, used for a concert by Instant Composers Pool – Old photo: Gemeente Amsterdam Stadsarchief. Colour photo: SITP (Space is the Place, 16th November 2023) – Collage by the author.

Today, it is a building with multiple activities and uses, reflecting the group occupying it and its organisational system. It is a collective project where it becomes evident how the politics and characteristics of the group constitute the building's meaning through the uses emerging from their collective practices.

The case of Plantage Dok is particular because, over time, two distinct types of transformation are visible. From the original church, the building was reprogrammed three times, becoming a school, a printing press, and a vocational training school. All of these transformations were carried out through pre-established designs, mostly involving significant material and formal changes. After its occupation in 1998, a new reprogramming process emerged, focused on the use of the space as housing, workspaces, a café, and a central communal area. The nave of the original church, which remained throughout this entire process of change, served as the heart of the transformation (Fig.6).

This final transformation has minimal material impact. It is primarily approached from the dimension of the practices themselves (the social dimension) and the symbolic representations generated by a narrative and

identity process characterised by the presence and interaction of the intervening group. A concrete example of how places are incessantly produced, not only when design professionals shape the function, but also when ordinary people extract from the continuous abstract space, a delimited, identified, and named space - a significant Place- (De Certeau 1996, Etlin 1997). The building is divided into two sections (Fig.7): one for workshops and studios, and the other for housing. All shared spaces have been intervened and transformed collectively, from common areas to more private spaces. The transformations are collaborative, with all colleagues working together to contribute or offer assistance, beyond individual decisions in private spaces. In this context, it is important to emphasise that, being artisans<sup>5</sup>, the construction resources are broad and significant in terms of spatial identity, as each modification or improvement is influenced by direct, hands-on practice.

However, Plantage Dok is also a case that requires considering the original building as a starting point for the occupation. This approach not only challenges the neutrality of the occupation practices and their participants, but also questions the neutrality of

the existing materiality itself. This means understanding that practices are products of collective activities but are filtered and conditioned by the materiality of the occupied space. In this sense, the building is divided into two distinct and clearly defined sectors. The ground floor houses the workshops (such as print workshops, music studios, artist studios, design spaces, and carpentry - Fig.8) featuring a large floor with large spans. The upper floor, in contrast, accommodates housing for artists and families, with a more compact layout due to shorter spatial modulations.

The ground level of the project retains from the original building a modular plan with large spans and skylights in the ceiling, providing good lighting for the entire workshop area. Given the participation of multiple activities and diverse productions, this open floor was gradually subdivided over time to meet the growing demand for workshops of varying sizes. These spaces, along with the circulation areas, surround the central space of the former church, the community square (Dokzaal - Fig.6), adapting to different needs.

On the upper floors, the need to adapt the large offices into housing required internal divisions, primarily to create private rooms functioning as bedrooms, while the kitchens and

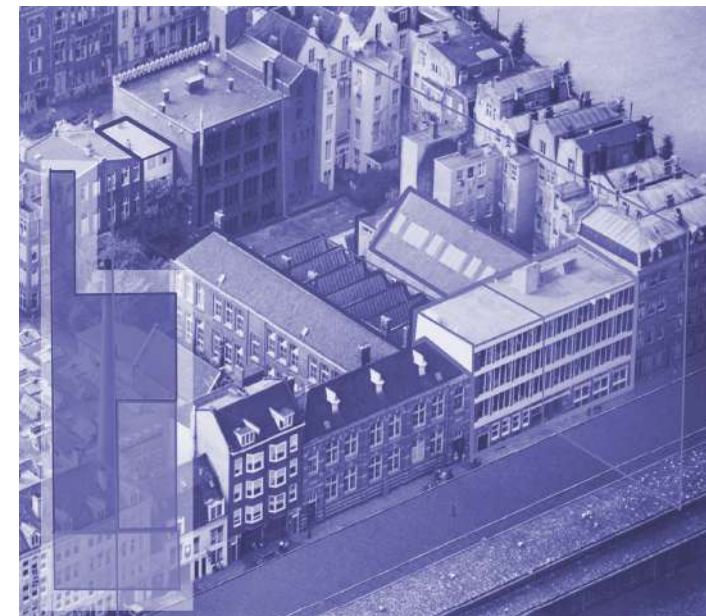

Fig.7 – Axonometric view of the Plantage Dok building. Source: Collage by the author based on an image from Gemeente Amsterdam Stadsarchief.



Fig.8 – Atelier at Plantage Dok - Source: Photo by the author (2024).



bathrooms remain mostly shared. This scheme of collective housing and artistic production workshops reflects what Plantage Dok is and proposes as a community and cultural project.

As there is no association structure requiring administrative or leadership figures, no space was allocated for offices in the occupation. Its assembly-based organisational system reduces spatial needs to a place for gathering, debating, and voting on collective decisions. The various commissions, each with different responsibilities, gather in the workshop spaces, which serve as meeting rooms. The former central hall of the church became a versatile space, functioning not only as an internal area but also, alongside the café, as a public-facing space. The ability to rent this central area is the only source of income for the collective. Today, the building has 56 units, including artist workshops and housing. These units each represent one vote in the assembly, even if more than one person lives or works in the space. All decisions made, such as dividing costs, admitting new members, or the use of the main hall, are discussed and voted on during assemblies.

Plantage Dok is the only case among the three that originates from an occupation, making it an example of a space committed to dissident and subversive practice. However, beyond that, this space

demonstrates how the occupants transform existing material spaces into meaningful and socially relevant places through their use. The place is, therefore, interpreted as the trace of the transformation practices of a particular group. This concrete element, rooted in its identity, gives the occupied space its meaning and significance. As a result, the space becomes both the medium and the condition for the process of social, material, and symbolic transformation.

#### *Temporality - Processual Architecture vs. Static Architecture (Kunstverein Wagenhallen)*

Another example of radicality through architectural practice based on use is the interpretation of temporality in relation to space. This position, deeply rooted in the occupation of spaces due to their temporary nature (risk of eviction or periodic contracts), proposes a reimagining of things as processes to achieve the reconceptualization of places (Massey 2005).

The continuous transformation of space is recognized as its essence, in contrast to a static, formalist view of architecture that treats spaces as discrete, predetermined entities. The reduction resulting from the abstract vision of space in disciplinary technification does not allow for the interpretation of space as a dynamic social system, open to transformation. Instead, it reduces space to a static abstraction, where it is merely seen as something that awaits form.

The case that illustrates this alternative and radical view on architecture is that of Kunstverein Wagenhallen in Stuttgart, Germany. This occupation takes place in a former building that originally functioned as a train wagon workshop. After being abandoned, it was occupied in 2003 by a collective of thirty local artists, through an agreement with the city council. Initially, the occupation was temporary, meaning that the association formed by the group did not have guaranteed permanence in the space. This directly influenced how the occupants practised and perceived temporary spaces and how they progressively changed them.

At first, the group used an open-plan space to carry out the work required for the productions of each artist or designer. The main advantage was the versatility and vastness of the central space, with large apertures. This allowed them to hold exhibitions, meetings, events, and anything that required gathering large groups of people for cultural expression. The city council had granted them full freedom to use and modify the space. However, given the temporary and financial conditions, as well as the broad liberties the building provided, the group's actions were typical of occupying and appropriating an existing space, predominantly for internal use.

Driven by the desire to use the space in direct relation to its

availability, the practices became confined to the internal boundaries of the existing structure. The focus shifted to constructing small ateliers beneath a large roof. The tactic was less about creating new volumes or restoring missing elements, and more about utilising the vacant space and inserting elements into those voids. Beyond this internal tactic of utilization, in the case of Wagenhallen, we can observe a constant and continuous transformation of the space through the dynamic activities stemming from its multiple cultural and educational practices. The ongoing process of change and activity clearly shows that space and its meaning are not fixed. Rather, they are constantly evolving and shaped through practice, reflecting the fact that human action is always unfinished (Lees 2001).

The multiple changes and successful transformations resulting from the occupation of Kunstverein Wagenhallen led the city council to intervene in 2015 with an ambitious restoration and technical upgrade project for the original building.

This intervention, however, meant that by this time, the collective of artists had grown to approximately 100 members, which was four times larger than initially planned. Consequently, they were unable to use their workspaces.

As a result, a new process of adaptation and transformation began, where the entire collective had to temporarily relocate from the original building to the outer areas of the property. This marked the beginning of a new symbolic phase, where it became necessary to create a new space for use. It was established from scratch in the vicinity of the original building to retain ownership and presence over the new construction and the grounds.

The need led to the creation of a new communal space for collective use. This new common space was built from the ground up, now outward-facing, using available materials and driven entirely by practical needs and the necessity of use. The new transformation started with internal discussion groups, collective participation, joint

workshops, and a system of self-construction.

Over the following months, the process experienced continuous growth and dynamic readjustments. For the final stage of the project, the collective received assistance from a specialised group that provided technical data and general organisational support.

Today, both projects coexist, but not for long, as the city council plans to construct a concert hall on the exterior grounds of the building, with potential future developments including residential housing. However, Wagenhallen stands as an example of radical architecture because it demonstrates how diverse and continuous practices, developed within the fixed physical space, gradually shape its spatialisation from the ground up. These practices, sustained by collectively constructed expressions, insert time as an intrinsic variable of the space into the static and purely formalist vision of the architectural discipline. They reflect the shifting dynamics of actors, identities, and politics in a place, uncovering its

#### WAGENHALLEN - STUTTGART, GERMANY.

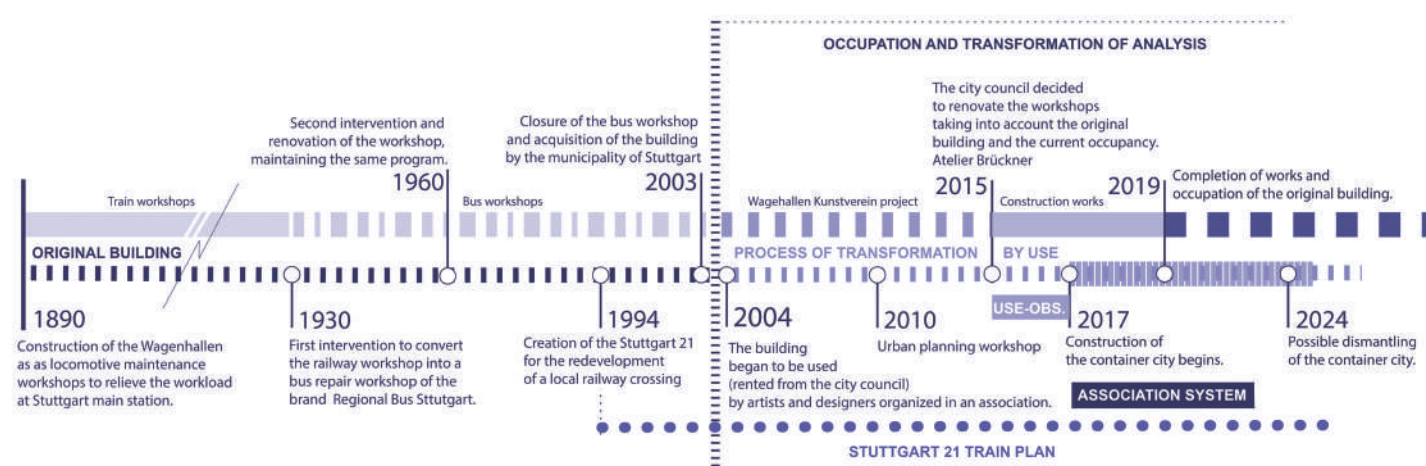

Fig.9 - Temporal development of the spatial process - Timeline by the author.



Fig.10 - Photograph of the original state of the main building, with a photomontage of the ateliers and studios intervention. Source: Color photo by the author (2024); black and white photo from Stuttgart General Archives; photomontage by the author.



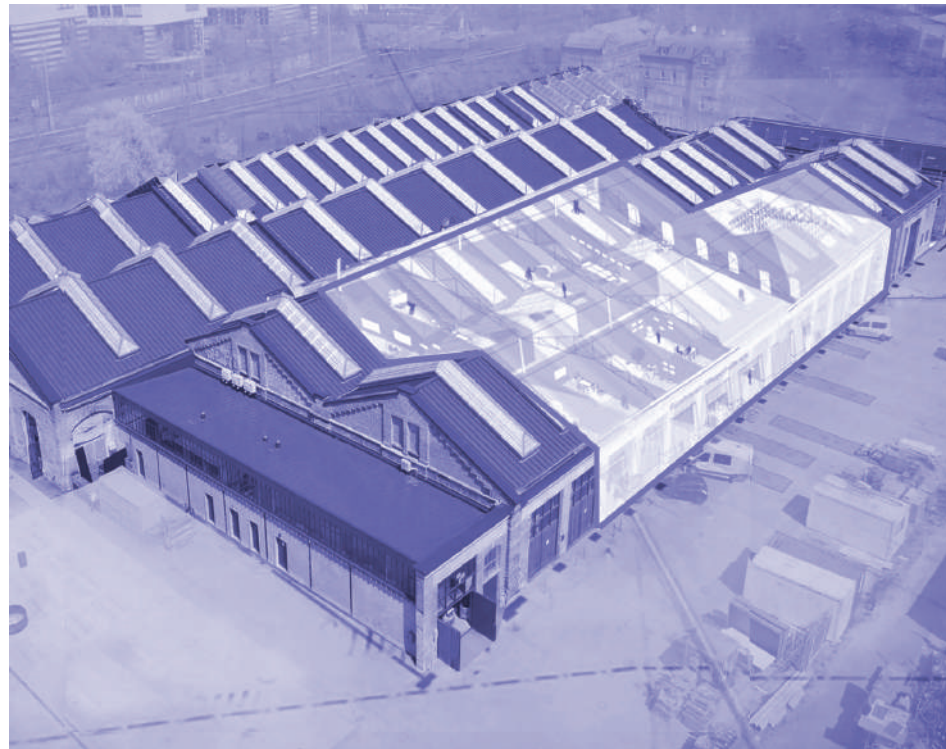

Fig.11 – Aerial view of the main building with an axonometric representation of internal ateliers - Source: Aerial photo by Atelier Brückner, axonometric design by Studio Malta, photomontage by the author.

emerging complexity.

The traces of use and appropriation expose the functioning of time and the overlap of different temporalities in all their historical richness. When analysing the practices of transformation in Wagenhallen, it is clear that they propose radicality by advocating for an architecture based on continuous transformation.

The dynamics of contemporary society are reflected in the space, organised and collectively built from interests, relationships, and conflicts.

There are numerous examples of collective occupations that illustrate space as an open, ongoing production. As a form of radicality, in disciplinary architecture, this means shifting away from thinking mainly in terms of predetermined designs and static spaces. Instead, it interprets space and its production as a continuous process, shaped directly by social practices and material objects.

## CONCLUSION

The transformation of unused spaces through occupation and

appropriation by collectives with cultural purposes, as seen in Mercato Sonato, Plantage Dok, and Wagenhallen, highlights the powerful role of collective actions. The continuous reshaping of these spaces through everyday practices demonstrates how such actions challenge and redefine traditional architectural concepts. By focusing on the social practices within these processes, these cases exemplify radicalism through a space understood based on human experience and collective meaning, what we refer to as Place.

This approach reveals radical architectural tactics that bridge the gap between available resources and everyday life, reshaping how we study space by incorporating social elements as essential factors. It goes beyond the geometric and formal boundaries of disciplinary architecture by integrating temporality and process.

The reprogramming of spaces calls attention to the durability of a building and its potential obsolescence, no longer determined solely by its physical properties but by the evolving social system. This obsolescence is not a "natural process" but one influenced by

cultural categories and social dynamics. Despite its relatively durable and imposing materiality, the meaning or value of a Place is fragile-flexible in the hands of different people or cultures, malleable over time, and inevitably questioned (Gieryn 2000, 465).

In an era dominated by superficial and illusory constructs, a root level subversive approach requires challenging a hegemonic language of abstract representation and proposing tools that address its limiting perspective. Moving away from the conventional view of architecture as resistant to change, with function as its only criterion, I instead construct a social and relational space through practice (one that disrupts the false equivalence between space and representation). Actions, uses, and needs become the foundation for producing a Place.

Engaging in the occupation and appropriation of buildings inherently involves a stance on the significance of space, recognising its role in shaping social and political relationships. This strategic value of space makes its control a subject of dispute, with its production, transformation, and intervention driven by political intents. This is crucial for understanding the dynamics of conflict, change, and transformation in our cities and societies.

Building on this premise, the radical nature of the spatial transformation practices based on use, as observed and described in this work, suggests a critical position towards the hegemonic ways of producing space in contemporary architecture. By incorporating temporality, identity, interaction, and politics, these practices redefine architecture through social action itself. These effective case studies offer tangible and impactful ways of making architecture from everyday practices of use. The next challenge will be to determine how these practices can be adapted and transformed within a new, alternative and radical architectural approach that moves beyond traditional frameworks.

## BIBLIOGRAPHY

ABU-LUGHOD, Janet, 1966. The city is dead - long live the city: Some thoughts on urbanity. *The American behavioral scientist*. Online. 1966. Vol. 10, no. 1, p. 3-5. DOI 10.1177/000276426601000102.

ANDERSON, Perry, 2016. *Los orígenes de la posmodernidad*. Ediciones Akal. ISBN 9788446042822.

COLLINS, Randall, 2005. *Interaction Ritual Chains*. Princeton Studies in Cultural Sociology.

DE CERTEAU, Michel, 1996. *La invención de lo cotidiano: artes de hacer*. Universidad Iberoamericana. ISBN 9789688592595.

ETLIN, Richard A., 1997. Space, stone, and spirit: the meaning of place. In: ROUTLEDGE (ed.), *The Eight Technologies of Otherness*. ISBN 9780203440230.

FINE, Gary Alan, 2012. Group culture and the interaction order: Local sociology on the Meso-level. *Annual review of sociology*. Online. 2012. Vol. 38, no. 1, p. 159-179. DOI 10.1146/annurev-soc-071811-145518.

GIDDENS, Anthony, 1984. *The constitution of society: Outline of the theory of structuration*. Oxford: Polity Press. ISBN 9780745600062.

GIERYN, Thomas F., 2000. A space for place in sociology. *Annual review of sociology*. Online. 2000. Vol. 26, no. 1, p. 463-496. DOI 10.1146/annurev.soc.26.1.463.

LEES, L., 2001. Towards a critical geography of architecture: the case of an ersatz Colosseum. *Ecumene*. Online. 2001. Vol. 8, no. 1, p. 51-86. DOI 10.1191/096746001701556904.

LEFEBVRE, Henri, 1978. *La pensée marxiste et la ville*. Tournai: Casterman.

MASSEY, Doreen B., 2005. *For Space*. Thousand Oaks, CA, USA: SAGE Publications. ISBN 9781412903622.

MIESSEN, Markus, 2011. *The Nightmare of Participation (crossbench Praxis as a Mode of Criticality)*. New York, NY, USA: Sternberg Press. ISBN 9781934105566.

OSWALT, Philipp, OVERMEYER, Klaus and MISSELWITZ, Philipp, 2013. *Urban catalyst: The power of temporary use*. Berlin, Germany: DOM. ISBN 9783869222615.

TILL, Jeremy, 2013. *Architecture Depends*. London: MIT Press. ISBN 9780262518789.

YIN, Robert, 2017. *Case Study Research and Applications: Design and Methods*. California, USA: SAGE Publications, Inc. ISBN 9781506336169.

## NOTES

1. LE CORBUSIER, 1964. *La Ville radieuse, éléments d'une doctrine d'urbanisme pour l'équipement de la civilisation machiniste*. Paris: Vincent Fréal.

2. For further reading, see JAMESON, Fredric, 1992. *Postmodernism, or, the cultural logic of late capitalism*. Durham, NC, USA: Duke University Press and ANDERSON, Perry, 1998. *The origins of postmodernity*. London: Verso Books.

3. Mercato Sonato was part of ARCI (Associazione Ricreativa e Culturale Italiana), and membership in this association was a key source of its regular income.

4. The architectural firm chosen by the city council to design the new building held only two open participation meetings (without observing activities) four years before the construction of the project and at the beginning of the occupation activities (Source: interview with Matteo Parmeggiani and Tomasso Ussardi).

5. The expansion of the term can be found in works such as *The Craftsman* (Sennett 2008), which explores how the practice of craftsmanship relates to culture, identity, and social well-being, or *Art and Agency* (Gell 1998), which delves into the relationship between art, handcrafted objects, and social agency.

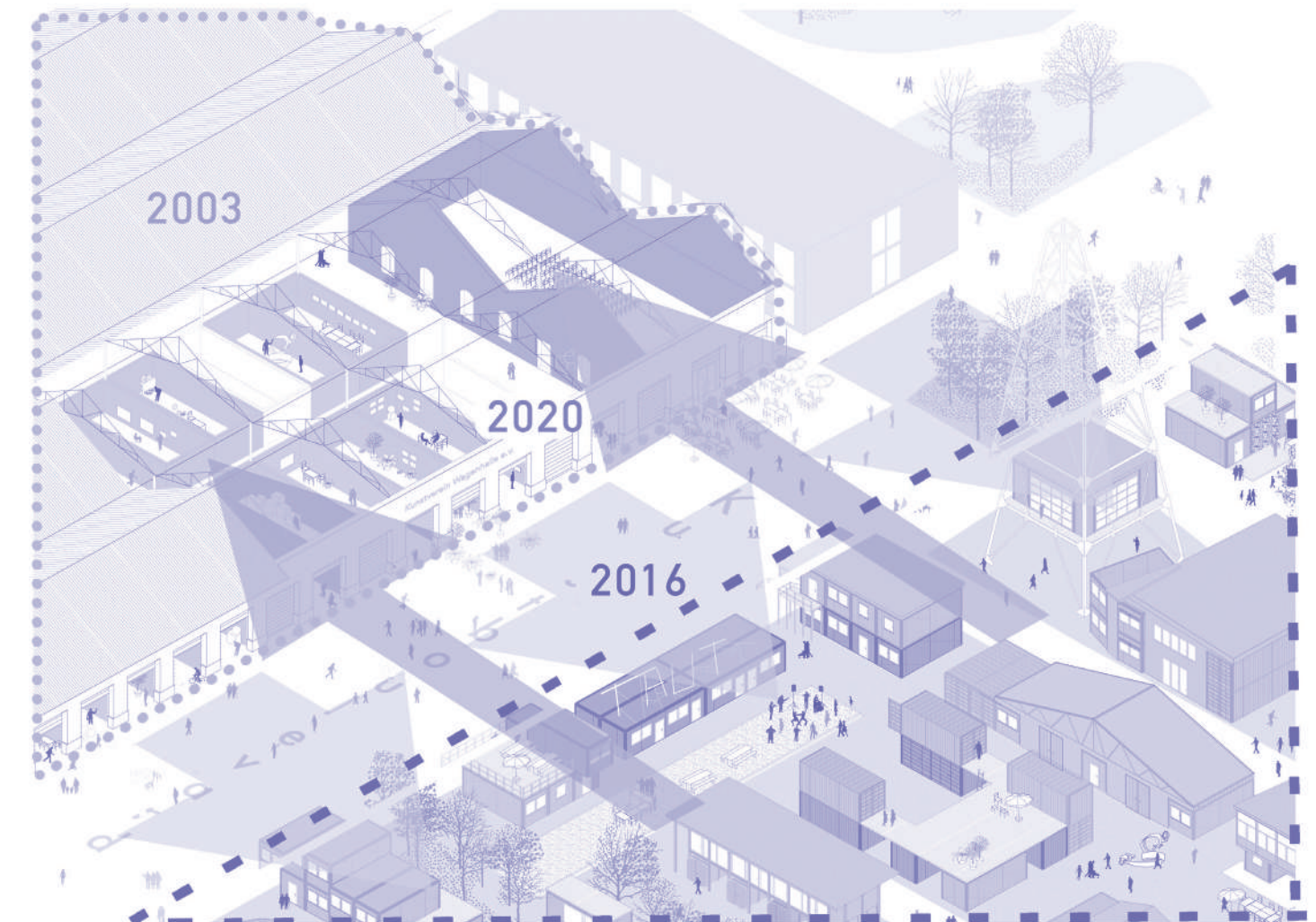

Fig.12 – 2003: Original occupation. 2016: Commencement of work on the main building and occupation of the exterior site. 2020: Return to the original building while maintaining both spaces. Source: Axonometric design by Studio Malta, edited by the author (2024).



# Radical devices

## Rethinking Art and Architecture as Forms of Dissensus in Urban Environments

commons  
 architettura  
 artefatto  
 ricerca artistica  
 spazio pubblico  
 radicalità  
**commons**  
**architecture**  
**artefact**  
**artistic research**  
**public space**  
**radicality**

L'obiettivo di questo articolo è quello di indagare le possibilità aperte dagli interventi radicali nello spazio pubblico: è possibile favorire la riflessione e creare una metodologia critica per analizzare il tema dei Commons nel contesto urbano? Presentando il progetto "Stente: Residual Zones" come esempio, l'obiettivo è esplorare queste domande utilizzando Umeå come caso di studio. Attraverso la creazione di un oggetto architettonico concepito come artefatto e installazione, il progetto cerca di utilizzare le pratiche artistiche e le teorie architettoniche come strumenti per coinvolgere i residenti della città in un dialogo attivo sugli spazi comuni. Partendo da un quadro teorico per collocare il potenziale critico dell'arte e dell'esperimento architettonico negli spazi pubblici, in questo lavoro il progetto è visto come un esempio di dispositivo critico temporaneo in movimento, che raccoglie e amplifica le voci degli abitanti attraverso la città: vuole rappresentare un invito aperto a reinterpretare i confini tra natura e città, ponendosi come una forma radicale (dal latino radicalis) di dissenso (Rancière 2010). L'esperimento è stato condotto presso la Umeå School of Architecture tra marzo e maggio 2024 nell'ambito del gruppo di ricerca "Designing the Contemporary City" dell'Università di Umeå.

The aim of this paper is to investigate the possibilities opened up by radical interventions in public space: is it possible to foster reflection and create a critical methodology for analysing the topic of Commons in the urban context? Presenting the project "Stente: Residual Zones" as an example, the aim is to explore these questions using Umeå School of Architecture as a case study. Through the creation of an art/architectural object, the project seeks to use artistic and architectural practices as tools to engage city residents in an active dialogue about Common spaces. Starting with a theoretical framework for situating the critical potential of art and architectural objects in public spaces, in this paper the project is seen as an example of a temporary critical moving device, gathering and amplifying the voices of the inhabitants through the city: it aims to represent an open-ended invitation to reinterpret the boundaries between nature and the city, posing itself as a radical (from the latin radicalis) form of dissensus (Rancière 2010). The experiment was conducted at the Umeå School of Architecture between March and May 2024 within the research group "Designing the Contemporary City" at Umeå University.

**Nobile, Maria Luna<sup>1</sup>; Melina, Francesca<sup>2</sup>**

<sup>1</sup> Umeå School of Architecture, Umeå University, Associate Professor in Architecture, Umeå, Sweden.  
<https://orcid.org/0000-0001-8958-2999>  
 maria.nobile@umu.se

<sup>2</sup> USS Pavia, Ca' Foscari University of Venice, PhD SDC in Environmental Philosophy, Venice, Italy.  
 francesca.melina@iusspavia.it

Citation: Nobile, M.L.; Melina, F. (2024). "Radical devices", UOU scientific journal #08, 116-129.

ISSN: 2697-1518. <https://doi.org/10.14198/UOU.2024.8.12>  
 This document is under a Creative Commons Attribution 4.0 International license (CC BY 4.0)

Invited Article 



## INTRODUCTION

Buildings that have lost their original function, machines to be inhabited again, empty areas and complexes that have lost their original purposes are more and more central to the current architectural debate. Looking at our cities and urban context/s at different latitudes we realise that architecture has a responsibility in acting by considering a "new reality". This reflection on the notion of re-use and re-activation of empty areas is a starting point to investigate new practices and dynamics development of our contemporary world.

In the everyday practice architects are constantly facing simple questions; For whom do we design? When does a space become a place? What is the limit between material and immaterial actions and when does architecture have a real impact on society? How do we live *in Common*? We could think about these questions and reflect on them from a radical perspective. This essay is based on an experiment that sees architecture and art intersecting other disciplinary fields. The experiment, central to this essay, has been conducted at Umeå School of Architecture between March and May 2024 as a result of a theoretical study on the notion of Commons in the urban context.

By looking at the specific context of Umeå, in the north of Sweden, authors reflect on how radical interventions in the public space can define a method to read and understand this reality, fostering an active dialogue among experts, the city and its inhabitants.<sup>2</sup>

## PLACING THE MATTER IN CONTEXT

Our epoch seems to be one in which everything has to be re-discussed, tested and reshaped. On the one hand, we have evidence of an increasingly immaterial world, detached from the immanence of the sensible promoting new technologies (e.g. AI) that allow us to reach unknown stages

of abstraction. On the other hand, we have to face the issues raised by global warming and the environmental crisis we are witnessing - and we can say that there is nothing more related to sensible and materiality than this. Among this apparent contradiction between two possible different readings of the world, a space of critical reflection is what is needed - meaning reflection both in its material and immaterial sense.

The premise from which it's possible to try to build this space is regarding a shift that humanity cannot ignore anymore: the concept of Anthropocene as that which has raised consciousness about what the world is facing today. This is for mainly two reasons. Firstly, *nature* - which used to be considered the immutable stage for human actions - is reacting to the violent actions of humanity. Secondly, innovation and science itself are party to the cause of the environmental collapse being witnessed. Assuming the idea of an increasingly immaterial world or the need for a more material comprehension of what is around are two sides of the same coin. What humanity has to face is the necessity of finding new forms of access to the world and new possible paradigms to read our contemporary situation: the failure of such concepts as progress, neutral knowledge and rationality and science as a universal model clearly shows the impossibility of further using the currently adopted systems of thought. What is called into question is the opposition between nature and culture - the foundation of the seeming contradiction between a material/ immaterial vision of the world. Secondly, knowledge production needs to be historicized within a social, political and economic framework.

In this sense, it's important to reflect on the city as constructed by humans and on the osmotic ecological relationship between them and the city. The city has been defined as the human thing *par excellence*. *The city, for its genesis and due to its nature, results simultaneously from the biological*

*procession, from organic evolution and aesthetic creation. It is, at the same time, object of nature and subject of culture; individual and group; lived and dreamed; human thing par excellence* (Lévi-Strauss 1968). Following Lévi-Strauss' definition of the city it is important for us to reflect on the notion of ecology - from the Greek *oikos* (home, but also collective) + *logos* (discourse) - indicates the study of the relationships between living organisms and the environment they inhabit. The concept of ecology, as the relationship between human beings and their own environment, can be found in the way we - as human beings coexisting together with non-human entities - live in the city (Nobile 2007).

## A NEW BODY-CENTRED PARADIGM

What, then, can be a new orientational paradigm useful to face Anthropocene challenges and to embrace the material-immateriality of the world? The idea of a new *body-centred paradigm* is what this paper would like to argue as something that can bring together the material and immaterial visions of the world. This is starting to rethink the relationship with materiality to develop critical theories to re-read what's immaterial. The proposal is to shift from what is rationality, culture, and science to what is sensible, nature and perception. This perspective discloses two different possibilities: on the one hand, to see how the body shapes peoples' way of acting and building the surrounding world, indicating new possible understandings of human history; on the other hand, to recognize how the body is fully and constantly affected by the environment itself, unveiling social structures' dependency on environmental aspects. The consequences of these two possibilities open up what has been defined as a "*necessary critical space*" in terms of an epistemological transformation: it seems possible to think of knowledge as something characterised by mutual exchange, blurring the boundaries of what

is usually considered inside and outside. Moreover, this leads to an openness towards otherness, where the human perspective is just one among others. Applying this perspective to society as a whole means to shift from bodies to what one might call social bodies. The body-oriented paradigm produces a shift in how the subject produces knowledge, but also a wider epistemological transformation (Renn 2020) involving the social body in its entirety. In other words, it's necessary to see the social body itself as affecting and affected, as a perceiving element that acts to shape - and is shaped by - the environment. Concerning this epistemological turn, perhaps it would be better to speak of cultural bodies instead of social bodies, to better understand what is meant. Different cultural bodies are characterised by forms of knowledge belonging to different social bodies in different parts of the world. It would, then, seem possible to speak of the need for new cultural bodies that respond to the necessity of building a common vision of the world that embraces this openness as the main outcome of the body-oriented paradigm. This enables new readings on the relationship between nature and culture, human and non-human, body and environment.

This reflection has its foundation in the Radical Movement, and in specific this experiment relates to the work of Archizoom Associati in the late 60's. The reflection on the body/space paradigm lies in the interpretation of the work of Andrea Branzi, a series of projects relating the domestic environment with the notion of theatre and scenography (Fig.1). A social space, a space for fun (Devereux, Alvado Bañón, Hadjisoteriou 2021). In this sense, the interpretation of the space is highly influenced by the perception we have of objects in the space, and how form, static and pure, can become dynamic when the relationship between the human dimension and the space are designed and reconfigured.

In the exhibition "THE FOUR BEDS" held at "Institut d'art Contemporain

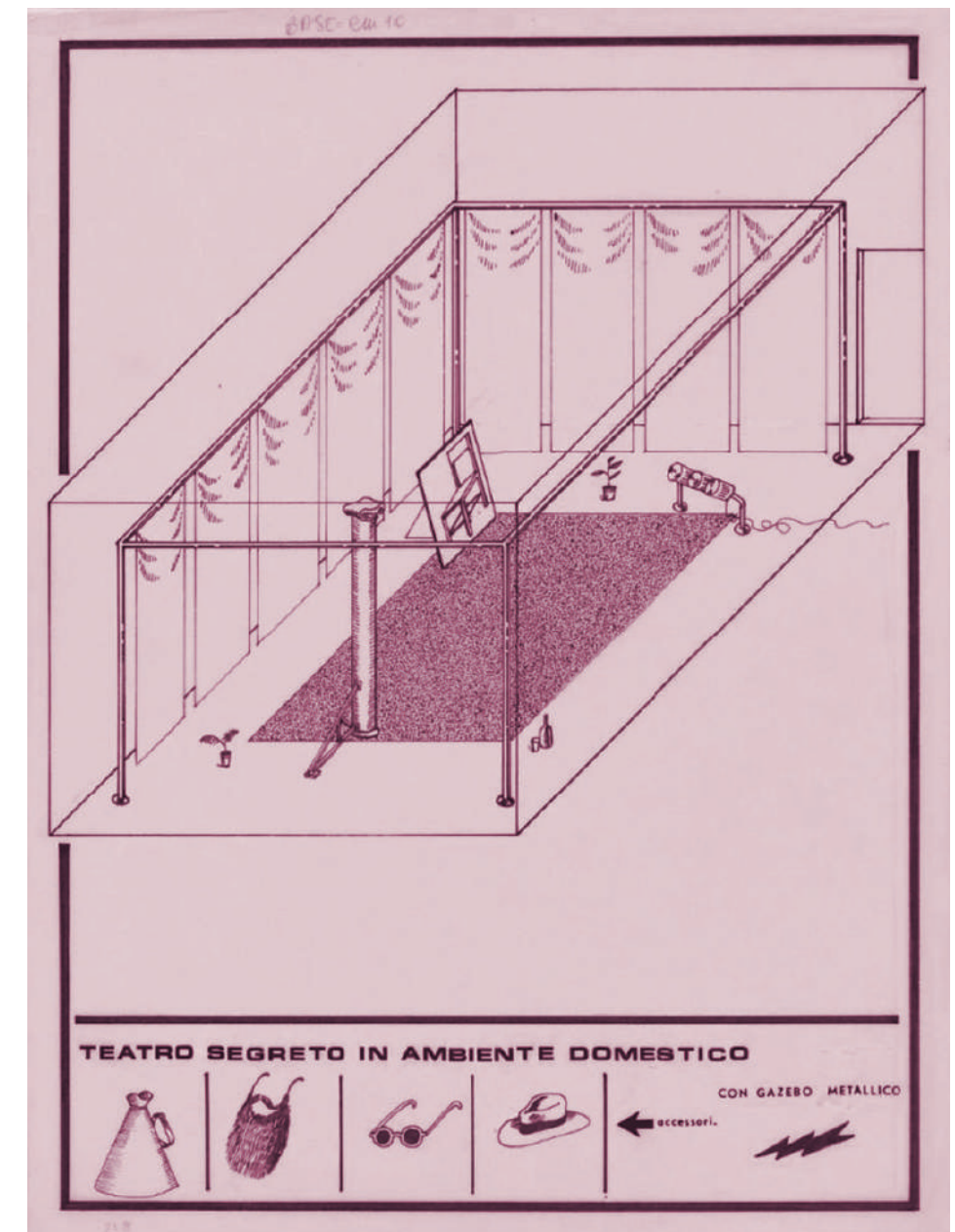

Fig.1 - Andrea Branzi, Archizoom Associati. Teatro segreto in ambiente domestico, 1968. Centre Pompidou Paris. Courtesy of © Adapp, Paris.

Villeurbanne/Rhône Alpes" in Lyon, 1967, Ettore Sottsass asked each of the Archizooms to design a bed in an environment on a scale of 1:10 to introduce the group in Domus issue number 455. These four beds are the manifesto of Radical Architecture. Here we maintain that the invention that comes before the product is its typological invention, that the object of design is not an archetype, an abstract geometrical form that is as elementary as possible - the better to meet the so-called principles of rational manufacturing - but the representation of an imagination, a piece of life that attracts a specific intended user who dreams of rainbows and loves Bob Dylan, and

that recognizes that pop imagery is a revaluation of popular taste, or kitsch, against the good taste of elegant, composed, geometric, white Braun-style design (Sottsass 1967).

Another reference is the work of Ugo La Pietra in the famous experiment *Commutatore Urbano* where the artefact is a device that re-establishes new parameters between the body and space.

We can refer to these readings, but it's important to go beyond, as Andrea Branzi argue in a recent interview:

*The legacy of the twentieth century, its dogmas and its principles of ethics,*



are obsolete and useless; the twenty-first century presents itself with totally original and contradictory features, which need to be reflected upon in an exploratory way, without attempting to recreate a new orthodoxy, but rather a rarefied system of anarchic hypotheses and experimentation, more akin to an era like ours – experimental and anarchic (Branzi 2014).

## SPACE AND COMMONS

At the centre of this investigation, as this paper would like to argue, is the concept of space, both built and natural. Space is a place from which it is possible to analyse humans' relationship with the environment and actively enact this new vision of the world that builds a more eco-logical relationship open to different perspectives and uses. It is feasible to say, to sum up, that the whole issue is a matter of space and, to go more into depth, a matter of the idea of the City (or the urban dimension), considered a privileged space where to enact this commutation towards new forms of inhabiting and acknowledging the world. The urban dimension, indeed, can be considered as a *Second Nature* (Vercellone 2013) built by humans to adapt, creating their environment. It represents humanity's emancipation from savage nature. So, to say it is the space where humanity has enacted the separation from what's material, sensible and related to a more body-related dimension affirming its superiority. It's the place to be for a science that stands apart from the world, from history and social implication: it's the habitat for the paradigm of Universal Rationality, for the unstoppable progress that has led us to the present environmental crisis (Renn 2020). That's why starting from this specific dimension, it is possible to look at the history of humanity from a different lens and try to rewrite ways of behaving in the world.

How can this change be actively implemented in terms of producing new concepts? How can the space in its material and immaterial

definition be defined and through what methods? The proposal looks at art and architectural practices in spaces to see how this process can respond to the need to create a new common vision of the world: namely going from an immaterial collective to a material collective creating new Commons. What idea of space is to be assumed? The notion of Commons seems to be a guiding concept from which it is possible to start to unfold this argument. The Encyclopedia Treccani defines Commons in the following terms:

*The set of resources, both material and immaterial, used by multiple individuals and which can be considered as the collective heritage of humanity* (Treccani 2012).

This collective heritage of humanity can be defined in terms of spatial dimension as follows:

*Understood as distinct from public as well from private spaces, Common space emerged in the contemporary metropolis as sites open to public use in which, however, rules and forms of use do not depend upon and are not controlled by a prevailing authority. It is through practices of commoning, practices which define and produce goods and services to be shared, that certain city spaces are created as common spaces* (Stavrvides 2016, p.2).

It is possible to shed light on several characteristics underlined by this definition. Firstly, it implies a community: a plurality of people sharing resources and governing them and their everyday activity in common (Commoning). On the other hand, the rules and types of use which are in form in it do not depend upon and are not controlled by a prevailing authority. Finally, there's a structure of shared knowledge as shared information about values and behaviours circulating within it (Stavrvides 2016).

## ART AND ARCHITECTURE AS COMMONS' ACTIVATORS

Why art and architecture and how to relate them to this concept?

To go more in-depth, can art and architecture have an impact in the way communities are defining a new sense of belonging in spaces? How do communities understand the space and how does the architectural project relate with the needs of a community? The relationship between these two disciplines in recent years seems to be the key to rethinking spaces in a new and more ecological way – to say it in other words as Commons. The idea of creating community and communal spaces underlies socially engaged artistic practices and an emerging typology of architecture that experiments with radical temporary structures. Starting from what is defined as the spatial turn in the 1970s we can see how from space considered as a «mere backdrop for an unfolding time, space became intimately linked to lived experience» (Dodd 2020, p.34). This new vision can be considered as related to a “realized abstraction” moving away from the old vision that considers space as related to the “conception” and the “perception”. This can be considered a more “comprehensive mode of spatial thinking” that moves:

*Beyond those traditional dualities (objective-subjective, material-mental) to create a “consciously spatial praxis based in a practical and political awareness that we can act to change” (Elden 2007, pp. 105-106) which was also seen by some as a way to “make theory practical” (Soja 2009, p.21) (Dodd 2020, p.36).*

This idea of new spatial praxis is strictly related to a political reading of space meant as a condition of “rupture and change” which Rancière calls “dissensus” to mean a redistribution of the sensible -see below (Rancière 2010). To quote the philosopher:

*I call the partition (partage) of the sensible, that system of sensible evidence that simultaneously makes visible the existence of something common and the divisions that, on that common, define places and respective parts. A partition of the sensible thus fixes at the same time a shared common and exclusive parts. This partition of parts and places*

*is based on a division (partage) of spaces, times and forms of activity that determine the very way in which a common lends itself to participation and the way in which one or the other will participate in this partition* (Rancière 2010, p. 15).

It's a partition of times and spaces, visible and invisible that defines what's common to a particular community of Commoning. The idea of space that takes shape from this perspective concerns a political vision of space as a place where to form new communities of practice, redefining the immaterial meaning of the space depending on the needs of the (temporary) interacting community – to say it with Rancière “who can have a share in the common depending on what they do”. It is possible to return to the idea of the cultural body and to analyse how this body is affected and affects the space it traverses. Also, the notion of Commons relates to the concept of process, time and fugitive democracy (Caneschi, 2021). Within this theoretical framework, art and architecture are seen as useful practices for analysing the characteristics of these interactions: it is a matter of making social bodies aware of the meanings attributed by that specific social body to a space. On the other hand, they can provoke those meanings aiming to change perspective and create new qualitative nuances and new uses of the space. The critical space is now open both on the side of the analysis of the main characteristic of space and on the tangible chance to change its connotations.

*Art and politics [and also architecture] are both forms of dissensus, meaning they are exceptions to the logic of normal rules governing social interaction, where genuine political action involves an emanclipation from the conventional frames in which bodies are ordered* (Dodd, 2020, p.37).

This emancipation of bodies is what characterises what we can call the critical potential of art and architecture practice. They are related to the practical dimension of living in the city, involving different everyday practices but also breaking

the flux of habits. In the experience of works of art we are dealing with a new formation of practices, which implies the indeterminacy of the future and induces a renegotiation of other practices.

*If we want to understand art as a praxis of the imagination, we must understand the impulse that interaction with works of art gives to human practices as such* (Bertram, 2017).

Not only art but also some forms of architecture can provoke the same effect is what this paper would like to suggest. Now that the idea of space and the idea of what kind of practices are acting in it has been defined, it is possible to move to a practical sample to unfold other issues left behind.

## “STENTE: RESIDUAL ZONES” PROJECT AS AN EXPERIMENT

Within the constructed theoretical framework, it now seems necessary to give an example of the critical potential of an architectural intervention in the space. This project configures itself as an artefact designed and produced in different phases by understanding the process itself as a practice. From the idea to the concept and its testing in the space, the artefact becomes an architecture that makes possible an artistic practice. Conceived as a performative device in the urban space the artefact has been conceived as a central element in the project. Not claiming what will follow as a solution or a final proposal on how things have to be done, the aim is to try to analyse several criticalities and potentialities of the direct action in space.

Starting from what it's possible to call an unconventional approach to architecture, the aim of “Stente: Residual Zones” project was to build a movable device as a research tool that symbolises the necessity of the physical occupation of the space - making it Common. This project was implemented in Umeå at Umeå School of Architecture and in collaboration with the UmArts

Research Centre at Umeå University, in the period from the 16th of March to the 31st of May 2024. The goal was to portray the changing nature of the relationship between people and the environment in the area, trying to test the two research hypotheses: a). Art and art practices seen as potential producers of Common Spaces and Common Action; b). Art seen as a potential producer of dialogue and reflections toward the construction of a Common Knowledge. From this theoretical premise, the concept was to create a physical space of dialogue in which to involve the community in Umeå collecting their perspectives of inhabiting the city.

The data revealed by the inquiry would serve as a basis for further development of the research project involving different residual areas in the city of Umeå to define a framework of intervention for future actions. The main idea was to build a device that could potentially serve multiple uses: a movable living room, a portable tea house, a place of gathering and exchange.

## THE CONTEXT: UMEA AS A CASE-STUDY

As for every experimentation in situated art and architecture, the context of analysis was important in defining the goals: Umeå was taken as a fertile ground of experimentation due to several reasons. At first, the city can be considered a space in constant change due to its environmental condition: experiencing a harsh winter and a short but hot summer, the whole territory modifies in the different seasons of the year creating different spaces in terms of accessibility and uses. This is mainly in terms of places assigned for snow stacking and ice forming, which creates new potential pathways around the city and across the river and lakes.

Umeå is also currently facing an important transformation as demolition and reconstruction are in progress and the city aims at increasing the number of inhabitants in the next 20 years.



To add to this, Umeå results to be a fruitful field of analysis in relation to Commons: the ongoing transformations and urban regeneration projects of the last 10 years provide a reference, although during the winter months many of these spaces are inaccessible; at the same time, despite the lack of attention that there is within the urban context for the concept of commoning, it seems to be extremely present as far as the natural environment surrounding the city is concerned. This starts from the presence of a law that protects the relationship between human beings and the environment (Allemansrätten)<sup>3</sup> and that refers to the theme of common goods, identifying nature as the shared resource as far as its use and the caring relationship that should be entertained with it are concerned. On the other hand, the whole urban space is governed by strict rules regarding the uses and the accessibility of the spaces – going

from the distribution of what is public and private to laws that delimitate designated spaces for public speeches and that prohibit live music in the streets. For those reasons, it results of main interest to analyse the public perception of what can be considered Common or not – leading to the partition of the sensible discussed above (Fig.2).

## RESIDUES AS THE KEY CONCEPTUAL ELEMENT

To foster this exchange around the topic of interest, the concept of residue and residual spaces was taken as a suitable starting point. Why residue?

Understood as leftovers, unseen spaces that inherently contain multiple undisclosed perspectives and drawing inspiration from the concept introduced by Gilles Clément, residual spaces seem

to have particular characteristics useful to fulfil the scope of creating dialogue around the Commons (Clément 2005). They are liminal to society and contain a potential multiplicity: they can be considered as bordering spaces that blur the lines between culture and nature. On the other hand, they are connected to otherness: this is due to their being inhabited by plants, animals, and material objects that have regained their place due to the absence of human activity. Last but not least, they have a specific environmental character related to a past community: they have been excluded from the current cultural body but still being within the city. Working in cooperation with the ongoing research project *"Re-use and Re-activate Urban Voids: a Paradigm of the Contemporary City"*<sup>4</sup> the starting point of the research on-field was an analysis of the territory to locate unused and abandoned spaces – both private and public – to understand them

in the context of urban projects and potential regeneration spots. Focusing on public spaces, this overview was shifted to spaces along the roads and in the main squares, trying to understand what part of these spaces can be still considered residual – as the urban voids above mentioned: spaces characterised by a multiple of unexpressed potential but being unseen in everyday life. The city centre was taken as the research area: a path was designed through the city outlining the spaces corresponding to the underlined features in Fig.2. A device was then designed to be movable and to temporarily occupy those spaces, shedding light on them. Coming back to the idea of residue, a cooperation with a local ethnobotanist<sup>5</sup> was initiated to identify endemic species of plants whose usages and benefits were forgotten, despite their presence on the territory. The aim was to bring the inhabitants closer to the residues of their land, starting from the urban to the rural and forested ones. Several plants were selected which were capable of producing drinkable infusions: the infusions made with Taraxacum, Trifolium, Filipendula, Chamerion Angustifolium were the starting point for sparking the conversation. But where to find a meeting point between –architectural research – that produces temporary objects to occupy the space –design – which creates multifunctional objects to live differently in the space – and art – which works with concepts and representations to drive reflections? The concept of residue is once again useful to close the circle. The stone (Fig.3), as the representative of what's residual, was taken as the leading idea to create the aesthetic and artistic concept of the device. The tea house was not only decorated with stones whose textures trace the topography of the city but also as the main vehicle to attract people and make them interact: the movable device, in fact, serves stone tea. Being just a conceptual insight to foster people's attention, the infusions were made only with wild herbs, but this deceit was explained to start the

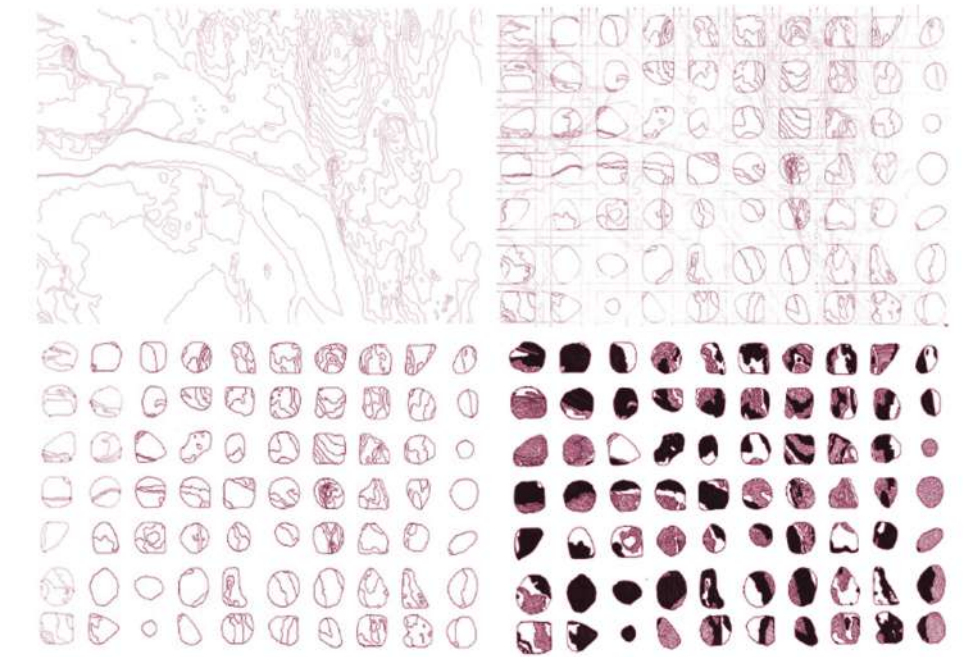

Fig.3 - Drawings made by Francesca Melina. Starting from the topography of the city, the aesthetic of the device was designed using the stone as the core element.

conversation around Commons and as a fruitful sample of what can be considered a residue. Starting from nature, that which the inhabitants are used to consider as a common resource in which to practise commoning, the discussion was driven by the urban and the city, their rules and potential uses.

## PRACTICAL EXPERIMENTATION ON-FIELD

Several on-field experimentations were conducted to test the effectiveness of the device and provide the space for interviewing to the inhabitants. Starting from the map drawn underlying the residual spaces within the city centre, different spots were selected responding to the need to find the widest range possible of typologies of inhabitant's (students, adults, senior, families). The original idea was to follow a pathway touching all the residual spaces identified, moving circularly, the starting and ending point being UMA (Umeå School of Architecture). Part of the process, then, was the moving of the device itself: carrying the weight and walking around the urban spaces have to be understood as part of the practice of regaining the freedom of use of the city and

its public (common) spaces. It is a common practice requiring at least four people. These actors have been involved through a common call and a collective dinner organised at the School of Architecture in the first stage of the process to contact researchers and students interested in being an active part in the experiment.<sup>7</sup>

Due to the timeframe available, only three places among the whole selection were inserted in the final experimentation: the main square of the city centre, a green area in front of UMA (Umeå School of Architecture) and a spot along the river in the new pedestrian path as part of a regeneration project designed by Umeå Kommun in 2014. Different participatory methods have been tested going from a more direct approach, asking people to come and sit on the device and give a bit of their time in exchange for a drink of stone tea, to a silent and non-invasive one, leaving the device alone and observing its interaction with the environment and who might be crossing the space. As mentioned above, the context turns out to be crucial in defining the type of interaction with the community: the typology of availability and understanding of what the device was supposed to be, varies depending on the different location.



Fig.2 - Map of the city centre that underlines the spots individuated during the research phase as residual spaces. Credits: Danila Della Monica.





Fig.4 - Alongside the Ume River. Credits: Raphael Avellar M. De Vargas.

It seems necessary now to try to reconstruct all the process briefly introducing the changing conditions that determined the variations in the results obtained.

The experiment started on the 10th of May along the riverside (Fig.4). As briefly mentioned above, all the riverside was subjected to a massive regeneration intervention in 2014, when Umeå was nominated European Capital of Culture. The whole city was subjected to a large-scale operation where all the pathways along the river were built – also embracing the Umeå University Art Campus (including Umeå School of Architecture, Umeå Design Institute, Bildmuseet and Umeå School of Art). This place was chosen mainly because of its inaccessibility during the winter season: all the spaces used during the summer for wandering and picnicking, all the installations and playgrounds placed along the trails become useful places to accumulate snow and turn into sheets of ice. Not only in winter, when the space

is inaccessible and dangerous, but also several critical issues related to the usability of the trails in summer have been raised. The aim, then, was to understand better how the population perceived this temporary residual space. Despite its being so suitable from a theoretical perspective, this space proved to be a crossing point, used to move from the city centre and the suburbs (and vice versa): the inhabitants were not available to stop, sit and talk because they were in the middle of a transfer from one place to another. Just one father with their daughters stopped providing information seemingly contrary to the evidence of the facts. Although no one else seemed eager to spend time in that space, using it only as a crossing space to go from point A to point B, he was enthusiastic about the improvement brought about by the Municipality intervention. The absence of functional architectural objects for people to stop, such as benches or other supports, was further evidence. One aspect that has been confirmed by this exploration is the lack of connection

between the riverside and the city centre. Umeå has been an industrial city mainly having the river as an infrastructure. With the regeneration project of 2014 the river became a park connecting horizontally the west to the east. It resulted in the need to improve those connections north-south trying to improve the relationship with the water.

The second place where the experimentation was held was the main square Rådhusorget. It was the place where the test was most repeated. This is due to the diverse range of inhabitants who pass through this space every day and the nature of the square as a central meeting point within the city centre. The square is a big and empty space, in which some stalls and markets come to occupy around the year. Here both the leaving-the-device-alone and the direct interaction mode were explored. Interestingly, were the different outcomes and the emerging perspectives opened from the



Fig.5 and 6 - Experimenting in the main square of Umea. Credits: Francesca Melina, Raphael Avellar M. De Vargas.



Fig.7 - Portray of the device in front of UMA. Credits: Laura Bisbe Armengol.

dialogues: the square is perceived by the inhabitants as something useless compared to the parks and the green area inside the city centre. There is a clear need to have more green spaces – complaints were made that they were to be too little and too crowded during the sunny days – and more common gathering spaces for winter – a time of the year when most of the inhabitants stay at home due to climate conditions and the absence of other alternatives. Returning to the perception of the device in space, from a few inhabitants, it

wasn't sensed as something out of the place or strange – they used it as a bench (Fig.5), unconcerned about the people standing around the structure offering them tea. On the other hand, by some, it was perceived with suspicion, as something potentially dangerous – what kind of beverage are you really offering me? – and a lot of effort was put into engaging in a discussion (Fig.6). One of the main differences noted in this context of experimenting was the presence or absence of native speakers: the grade of suspiciousness increases

if no Swedish speakers were doing the first interaction. This is an observation that is valid for all the field experiments but seemed more evident in this space – being the one where most of the time was spent. Outcomes of the experiment in the second location Rådhusplanaden / Rådhusorget confirm that the main square designed in the same period of time as the riverfront, when Umeå has been elected as European Capital of Culture, is perceived by the inhabitants as an isolated island with no real connection with the main street Kungsgatan nor with



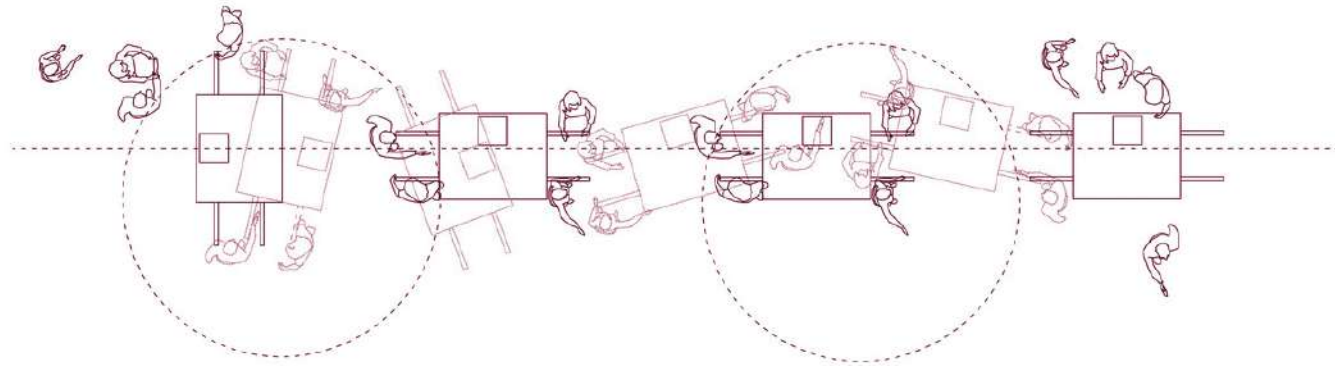

Fig.8 - Drawings by Maria Luna Nobile, observation of the device in movement and different interaction between the artefact, the space and the bodies.

parks and riverside. The design of the square, which has a specific infrastructure to keep it free from ice and snow during the winter time, is perceived as empty. The main Municipal Hall, now used only for special events appears like a scenographic background and on the opposite side the relation with Rådustorget - the streets that connect to the main train station - seems to be disconnected. Despite the ideal design of a square that responds to minimalist and modern criteria in relation to the design of the space, it seems not to be perceived by the users as a common space, rather as an institutional space.

The third and last space of experimentation was alongside the Umeå School of Architecture. Being in the middle between the Umeå Art School and UID Umeå Design Institute and Bildmuseet, the device in the space was perceived as an art/architectural installation - which it was. Placement influences people who are passing by and provides

the context for reading the meaning and intentions of the structure itself. A lot of curiosity was experienced in this location: questions and spontaneous interaction, direct interplay with the teapot and instinctive approaches to the reading material left on the wooden board of the device. It was, for sure, the most fertile space in terms of creating dialogue and fulfilling the scope of the art/architectural object - but also the least challenging. The space was selected as a pathway and a junction between different realities: the schools on one side and the city centre on the other. As for the riverside, there are no specific functions given to this space: no benches and no sitting spots, but only a gravel paving dividing the river and the meadow in front of UMA (Fig.7). The aim was to involve students, visitors of the museum and citizens walking along the river. The last category became the most attracted. The interaction confirmed what emerged during the previous conversations: the city seems to be not considered a space

of commoning but is mostly used to respond to consumerism needs and fulfil everyday duties. On the contrary, natural outdoor spaces are naturally perceived as gathering spaces: nothing more than a recognition sign is needed to give instructions to friends who want to gather. The winter season most of the time is not even mentioned: it seems to be a "bubble" where no interaction, despite the one devoted to work, are brought into consideration. The time of commoning is summer when the outdoors become fully accessible and the light shines for 23 hours.

The main outcome of all the on-field exploration was this disparity between nature perceived as a real Common and urban areas sensed as something not about a feeling of community and only used as crossing spaces. It is possible, then, to say that the law echoes the lived situation - with the Allemansrätten, on one hand, and the strict forbidding on the other side - but it does not mean that

the population is pleased with the way conditions are. Many were the objections towards the design and management of public spaces within the city. This also reflects a social and political framework that sees the State as an actor that provides facilities for the life of every inhabitant equally, that affects the way common and collective actions are perceived. What transpires from the interactions with the inhabitants is a general dissatisfaction with

the absence of spaces that can be used as gathering points and the presentation of voids, in the city of Umeå, of surfaces that have no specific use. In this sense the experiments have been extremely useful for this research, and it will lead to a future phase where proposals can be elaborated through a participatory process and a dialogue with the institutions can be held (Fig.8-9-10).

## FURTHER REFLECTIONS. WHY RADICAL?

This experiment has provided an opportunity to expand on reflections and now shared in this essay with a broader audience, hoping to spark further dialogue on the subject. To better understand why this experiment is deemed as radical, it is essential to first

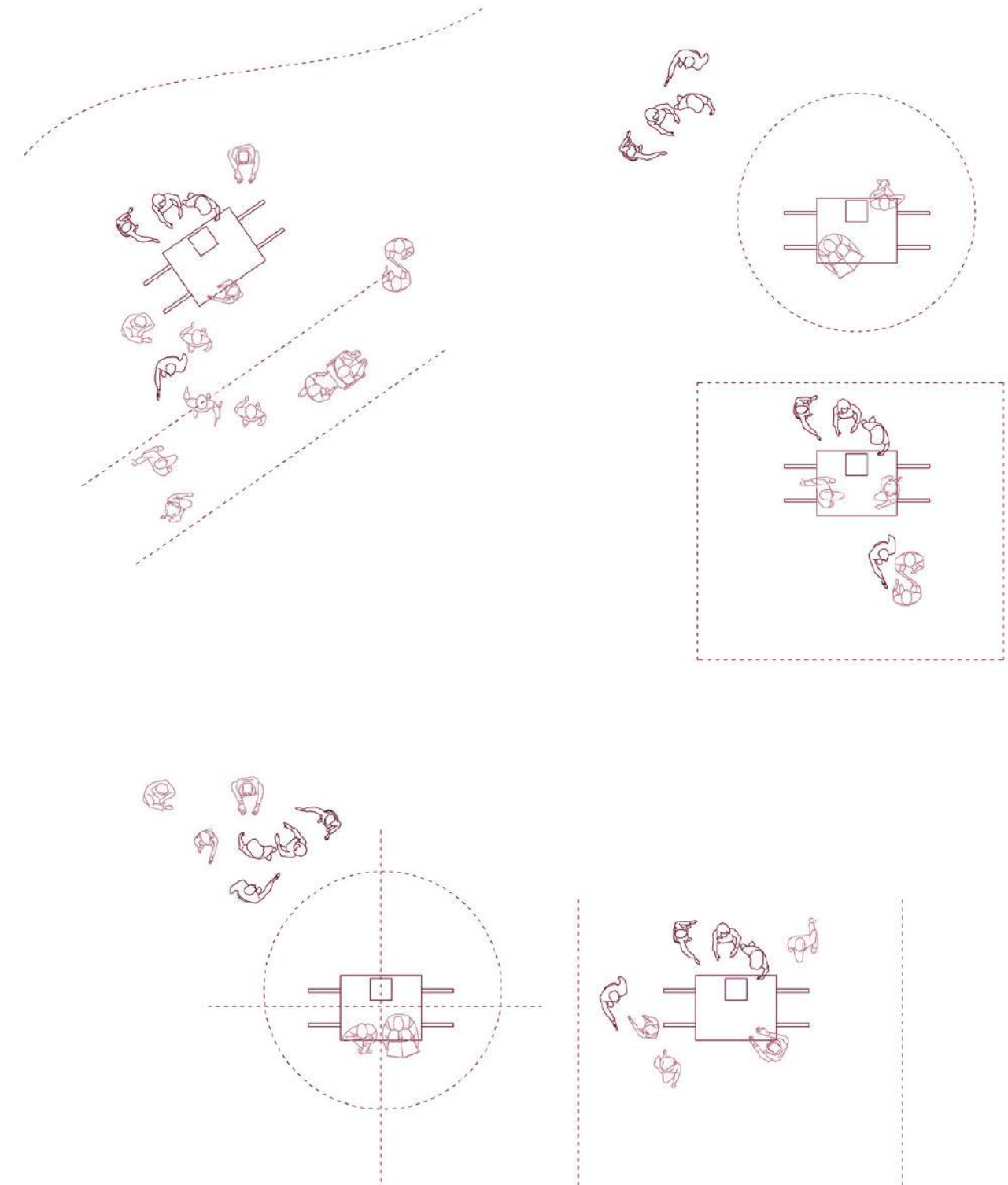

Fig.9 and 10 - Drawings by Maria Luna Nobile, analysis of the interaction between the artefact, the space and the bodies in the three spaces.



explore the meaning of the term in languages that are at the core of this experimentation, going from Italy to Sweden:

In Italian, "radicale"<sup>8</sup> derives from the Latin radicalis, itself rooted in radix, meaning "root." This botanical association emphasises an origin or fundamental essence. Figuratively, "radical" signifies a profound or foundational change, touching the core of something - whether an institution, a system, or even an individual's life. The radical is thus both intimate and transformative, fundamentally altering the status quo from its very foundation (Enciclopedia Treccani).

In Swedish, "radikal"<sup>9</sup> is similarly derived from radicalis and emphasises roots or origins. Over time, the term has extended to imply something thorough and deeply penetrating. It is often associated with transformative actions that address an issue at its root, aiming for profound and lasting change (Svenska Akademiens Ordbok 1956).

The experiment involves the creation of a simple, minimalist structure: a platform, pure white in colour. Like an archetype, this platform becomes a space for engagement, interaction, and dialogue. The interaction revolves around the use of tea roots and plants, with the stone serving as a metaphor for fundamental exchange. Both the physical space and the narrative it evokes embody a radical concept - returning to the roots, to the original, yet also acting as a blank canvas, a starting point for discussions on intimate and profound visions. This dialogue ultimately invites reflection on perception of body and space within the urban context.

Finally, this experiment challenges and invites reconsideration of the foundations upon which perceptions of space, body, and interaction are built. Returning to the roots - both literal and metaphorical - it invites us to unveil the layers of biopower complexity that modern urban environments often impose. The platform, with its minimalist form

and symbolic materials, is not just a space for dialogue, but an agent for dissensus. The project invites reflection on how to relate to one's surroundings and challenges the existing consensus about boundaries between nature and the built environment, between individual and collective experience. In doing so, it calls for a radical re-evaluation of how to inhabit the city and, more broadly, the world around us (Fig.11-12).

Rather than simply reminding that profound transformations often begin with the most elemental gestures - a *return to the root* - could this experiment, in its simplicity, align with Andrea Branzi's notion of a non-heroic, flexible approach to design? (Branzi 2006) In rethinking urban spaces and human interaction, could this return to the root be seen not just as a minimalist gesture, but as an open-ended invitation to reinterpret the boundaries between nature and the city? Can this fluid, adaptable structure serve as a new platform for understanding how to inhabit and transform urban environments?

## ACKNOWLEDGEMENT

The authors would like to thank for their active participation in the field experiment that was part of this research project: architect Danila Della Monica, ethnobotanist and forager Maria Eriksson (Bärände Produkter), visual and creative designer Gioele Bertin (Malomodo studio), Claudia, Dide, Eleonora, Stephanie, Silvia, Jonathan, photographers Raphael Avellar M. De Vargas and Laura Bisbe Armengol, UMA technicians Kent Brodin, Håkan Hansson, Sven-Erik Hilberer, Umeå School of Architecture and UmArts research centre and the community of researchers involved, and all the permanent or temporary inhabitants of Umeå who participated in our experiment.

## NOTES

1. In this text we refer to the role of art and architecture practices in the era of the Anthropocene. A "new reality" in which our disciplines are facing the need of dealing with urgent topics in relation to the current environmental and consequential social crisis.

2. Authors' contribution: The authors jointly conceived and developed the approach and the overall objective and structure of the paper. Paragraphs: "Stente: Residual Zones" Project as an Experiment, Residues as the key conceptual element, Practical Experimentation on-Field, Further Reflections. Why Radical?, are to be attributed to Maria Luna Nobile; Paragraphs: Placing the matter in context, A new body-centred paradigm, Space and Commons, Art and Architecture as Commons' Activator, are to be attributed to Francesca Melina.

3. For more complete information on this topic visit: <https://www.naturvardsverket.se/allemannsratten>. The law concerns the right to roam, camp and collect natural goods from forests and green areas surrounding urban agglomerations. It does not matter whether the space is regulated private or public. Some restrictions are applied to protect rare and wild green species. In general, the law considers access to and benefit from land as a common good.

4. The research project has its foundation in the UMA Research Group "Designing the contemporary city" and aims at testing the topic of reuse and reactivation through art and architecture in the city, Umeå is the main case study. Francesca Melina as visiting researcher and Danila Della Monica, as visiting master student, have been contributing to the group and been hosted at UMA in Spring 24.

5. The ethnobotanist and forager Maria Eriksson (Bärände Produkter) was fundamental in the process of knowing

better the land and the herbs growing in the area. Due to seasonal reasons also foraging as a practice is confined to a specific time of the year: it seems to be the perfect link to address the accessibility of the land, the city and the common spaces going from nature to the urban dimension. All the wild herbs used during the experimentation were also known for their healing properties: each quality was explained to the public interacting with the device.

6. The call for participants and the dinner to meet the interested participants is an integral part of the participatory method aiming at involving as much as possible each person who will contribute in the experiment actively in the process. During the dinner participants had the chance to meet each other and discuss the main topics and have an impact on the design process.

7. The entire experiment lasted for three weeks. There were three days of the first round of field trips, from May 10 to 13. Then, after collecting initial results, a second round was implemented at the end of May, on May 24 and May 29. This is a starting basis from which to construct future possible experimentation.

8. Radicale adj. e s. m. and f. [from lat. tardo radicalis, der. di radix -icis «radice»; ing. radical]. - 1. In botany, which refers to the root: hair r.; r. apparatus; suckers r.; veil r., see velo1, n. 3 a; r. absorption, which takes place by the root hairs; r. leaves, improprium., the basal leaves of the stem, which in certain plants appear to derive from the root. 2. fig. Which concerns the roots, the intimate essence of something: the foundation r. of the imperial majesty (Dante); to make a change in one's life, a turning point, full, total; r. renewal, r. reforms, which change or tend to change a system, an institution, etc., from the foundations (Enciclopedia Treccani).

9. Radikal [jfr t. radikal, eng. o. fr. radical; av senlat. radicalis, avledn. av lat. radix (gen. -icis), rot (se ROT)] 1. (nowadays hardly br.) bot. belonging to l. starting from the root of a plant etc. Radical shoots. BotN 1884, p. 30. 2. belonging to l. constituting the origin of something l. root; also: original, inherent; nowadays, among others in the case of something bad, usually. 3. which goes to something's root l. origin; usual in extended l. image l. anv., transitory in bet (Svenska Akademiens Ordbok, 1956).

## BIBLIOGRAPHY

BRANZI, A. The Primitive Metropolis, Fortino Editions, Miami 2014.

BRANZI, A. the No-Stop City - Archizoom Associati, HYX, 2006.

CANESCHI, F. (2021). From Commons to Urban Commons. Complexity and contradiction in the translation of a concept. UOU Scientific Journal, (01). Retrieved from <https://revistes.ua.es/uou/article/view/19512>

CLEMENT, G. Il Manifesto del Terzo Paesaggio, Quodlibet ed. 2005 (it. translation) pp. 10-17.

DEVEREUX, M., Alvado Bañón, J., & Hadjisoteriou, M. (2021). Conversation on a

common manifesto. UOU Scientific Journal, (01). Retrieved from <https://revistes.ua.es/uou/article/view/20265>

DODD, M., Spacial Practices. Modes of Action and Engagement with the City, London and New York, Routledge, 2020, pp. 33-57.

BERTRAM, G.W., L'arte come prassi umana, un'estetica, [2014] 2017, tr. it a cura di Bertinetto, A., e Vercellone, F., Milano, Raffaello Cortina Editore.

ENCYCLOPEDIA TRECCANI vocabolario online, Commons, [https://www.treccani.it/enciclopedia/information-commons\\_\(Lessico-del-XXI-Secolo\)/](https://www.treccani.it/enciclopedia/information-commons_(Lessico-del-XXI-Secolo)/) (accessed on the 13th of September 2024).

ENCYCLOPEDIA TRECCANI, vocabolario online, Radicale, <https://www.treccani.it/vocabolario/radicale/> (accessed on the 9th of September 2024).

LÉVI-STRAUSS, C. *Tristi tropici*, Il Saggiatore, Milano 1968.

NOBILE, M.L. voce "ecologia" in ARCHITETTURA enciclopedia dell'architettura vol.2 a cura di Aldo De Poli, Motta Architettura - il sole 24 ore, 2007 p. 111.

NOBILE, M. L. (2021). An introduction: the need of a space for experimentation. UOU Scientific Journal, (01). Retrieved from <https://revistes.ua.es/uou/article/view/20258>

NOBILE, M. L., ed. (2021). COMMONS. UOU Scientific Journal, (01).

SOTTSASS, E. Archizoom in Domus 455, October 1967. Text published in Domus web 9 March 2023 "Nice chaps, but naughty": Sotssass introducing Archizoom in the pages of Domus in the 60s. <https://www.domusweb.it/en/from-the-archive/2012/10/13/archizoom-good-fellas.html> (accessed on the 9th of September 2024).

SVENSKA AKADEMIENS ORDBOK, Radikal definition, 1956 [https://www.saob.se/artikel?unik=R\\_0001-0160.4iYS](https://www.saob.se/artikel?unik=R_0001-0160.4iYS) (accessed on the 9th of September 2024).

STAVRIDES, S. Common Space. The City as Commons, Zed Books 2016 p.2.

RANCIÈRE, J., Le partage du sensible. Esthétique et politique, La Fabrique editions, Paris, 2000; La partizione del sensibile. Estetica e politica, Derive Approdi, Roma, 2016, pp. 15-23.

RENN, J., The Evolution of Knowledge. Rethinking Science for the Anthropocene, Princeton University Press, Princeton, 2020, pp. 12-13.

VERCELLONE, F., *Dopo la morte dell'arte*, Bologna, Il Mulino, 2013.



Fig.11 and 12. Photos by Francesca Melina, experimentation during winter season, December 2024.



# **RADICAL TECHNOLOGY**



# The Architecture of Defying Gravity

An Exploration of Future Environments that Focuses on the Poetics, Innovation, and Potential of Airborne Architecture

**future environments**  
**gravity defiant**  
**airborne architecture**  
**sustainable futurism**

The evolution of architecture is a narrative of humanity's enduring aspiration to transcend the constraints of physical and environmental limitations. In the 21st century, this timeless pursuit has been reimagined through the innovative paradigm of Airborne Architecture, epitomized through the research of Gravity Defiant Architecture (GDA). This article delves into the origins, foundational principles, and transformative potential of GDA, with particular emphasis on the Rising Oases Saga - an ambitious project that exemplifies the poetic and revolutionary possibilities of architecture that defies gravity. By integrating a thorough literature review, in-depth case studies, and rigorous theoretical analysis, this article positions GDA within the broader continuum of architectural evolution, exploring its implications for sustainability, resilience, and ethical design. Ultimately, it proposes a radical vision of architecture that not only redefines the built environment but also fosters a profound harmony with the natural world.

**Kachaamy, Georges<sup>1</sup>**

<sup>1</sup> Director of the Centre for Research, Innovation, and Design (CRID), American University in Dubai (AUD), United Arab Emirates.  
<https://orcid.org/0000-0003-1845-7212>  
[gkachaamy@aud.edu](mailto:gkachaamy@aud.edu)

Citation: Kachaamy, G. (2024). "The Architecture of defying gravity", UOU scientific journal #08, 132-143.

ISSN: 2697-1518. <https://doi.org/10.14198/UOU.2024.8.13>  
This document is under a Creative Commons Attribution 4.0 International license (CC BY 4.0)

Article Received: 06/10/2024  
Received in revised form: 28/10/2024  
Accepted: 28/10/2024





## INTRODUCTION

From the dawn of civilization, the skies have served as a source of inspiration, embodying the unattainable and the divine. The celestial bodies - sun, moon, and stars - have long been revered, symbolizing the mysteries of the universe and the eternal quest for knowledge and transcendence. This fascination with the heavens has permeated every aspect of human culture, influencing mythology, religion, art, and, notably, architecture. Throughout history, architecture has been more than a mere response to functional needs; it has been an expression of humanity's desire to reach beyond the earthly and to connect with the skies. Tall buildings, whether religious or secular, have been culturally perceived as iconic landmarks and powerful symbols of authority and dominance (Dobraszczyk 2019, 108-110), embodying both spiritual ambition and societal influence. GDA also known as Airborne Architecture (Fig 1), emerges as an ambitious response to this ancient yearning and challenges conventional notions of architecture by proposing

structures that defy gravity, floating, hovering, and ascending into the sky. This article covers the philosophical and practical implications of GDA, and focuses on the case of Rising Oases Saga, a project that creates prototypes in order to bring this radical and innovative architecture closer to a tangible reality.

## THE THEORETICAL AND HISTORICAL BACKDROP OF GRAVITY DEFIANT ARCHITECTURE

The idea of defying gravity in architecture is deeply rooted in historical and cultural narratives. The exploration of verticality has been a central theme in architectural design reflecting humanity's enduring desire to reach beyond earthly constraints. This ambition, driven by technological advances and cultural aspirations, has not only shaped architectural endeavours but has also been reflected in other fields such as literature, art, engineering, and various

scientific pursuits, illustrating a longstanding fascination with transcending the limits of what might look unfeasible (Frampton 2007, 315-318). Throughout human history, celestial bodies appearing in the skies - mysterious and weightless - have been sources of adoration, admiration, inspiration, and aspiration. These heavenly objects have sparked a profound sense of wonder and a persistent aspiration to conquer the skies. This fascination with the celestial is evident across various cultures and eras, where the desire to levitate, fly, or transcend earthly limits is a common thread. One of the earliest and most significant figures in the history of human flight is Abbas Ibn Firnas (Fig.2), who is often credited as the first aviator. His experiments in the 9th century with gliding and attempted flight mark a crucial moment in the ongoing human quest to defy gravity. Ibn Firnas's pioneering spirit laid the groundwork for subsequent explorations into aviation and the possibilities of overcoming gravity (Anderson, 2024, 122-152).

The theme of levitation and anti-gravity has also been richly explored in literature, where authors have

imagined technologies and worlds free from the constraints of gravity. H.G. Wells's *First Men in the Moon* introduces the concept of "Cavorite," a fictional material that negates gravity, enabling space travel (James, 2012, 125-156). Similarly, James Blish's *Cities in Flight* series explores the idea of "spindizzy" technology, allowing entire cities to break free from their terrestrial anchors and move through space. These literary works, alongside others such as the "Laputa Flying Island" from Jonathan Swift's *Gulliver's Travels* (Fig.3) and the "Minerva Balloon" depicted in Etienne-Gaspard Robert's 1820 novel, eloquently embody the human aspiration to surpass the confines of physical limitations. This theme resonates deeply with the principles of GDA.

Historically, the desire to overcome the constraints of gravity can be observed as early as the construction of the Gothic cathedrals. With their pointed arches, ribbed vaults, and flying buttresses, these cathedrals were designed to reach toward the heavens. These architectural elements were not merely technical innovations; they were also profound symbolic gestures



Fig.2 - "Abbas Ibn Firnas" Mock-up at Ibn Battuta Mall in Dubai, United Arab Emirates.

designed to elevate the spiritual experience by directing the eyes - and the soul - upwards. As earthly dwellings of the Divine, Gothic cathedrals were intended to embody an otherworldly presence, achieved through their statuary, stained glass, and sheer scale, as well as their calculated transcendence of earthly limitations through architectural form (Trachtenberg and Hyman, 2002, pp. 223-227). This pursuit of verticality is exemplified by the soaring heights of structures like Notre Dame de Paris, which employed innovative

techniques to achieve an ethereal sense of lightness within their massive stone facades.

A particularly compelling example of the architectural aspiration to create the illusion of defying gravity is evident in the domes of Renaissance and Baroque churches. Architects of these eras adeptly employed light as a medium to evoke a sense of weightlessness within their designs. These domes, spanning expansive spaces and ascending to great heights, were ingeniously crafted



Fig.1 - "GDA" soaring above a natural context, a render by @gravitydefiantarchitecture.



Fig.3 - "Laputa Flying Island" (Left) and "Cloud Nine" (Right).



to appear as if they floated above the spaces below. This effect was achieved through the strategic incorporation of a ring of windows at the base of the domes, which permitted light to permeate the interior, creating an ethereal glow that gave the impression of the dome hovering effortlessly in mid-air. Filippo Brunelleschi's work, particularly his design of the dome for Florence Cathedral, employed innovative techniques to create an elevated, seemingly suspended form, challenging the structural limitations of his time. Brunelleschi's pioneering use of a double-shell construction and a herringbone brick pattern allowed for a more efficient distribution of weight, enabling the dome to soar prominently above the city and be visible from a great distance (King, 2000, pp. 160-167). This invention represented a groundbreaking advancement in architectural technology, as it facilitated the construction of a dome of unprecedented scale and complexity.

As Alberti noted, the dome appeared to rise "above the skies, ample enough to cover with its shadow all the Tuscan people" (Trachtenberg and Hyman, 2002, pp. 277-280). This represented

a significant advancement in architectural design, foreshadowing later efforts to achieve structural lightness and verticality. The play of light and shadow, combined with the architectural mastery of these domes, served as early explorations into the possibility of creating structures that appear to defy the limitations of gravity - an idea that resonates deeply with the principles of GDA.

With the advent of modernism, the 20th century brought a paradigm shift in architectural thinking. Le Corbusier, whose concept of pilotis exemplified in the Villa Savoye, revolutionized the architectural design and allowed buildings to "float" above the landscape. The liberation of the ground has fostered a new sense of spatial openness by allowing the natural landscape or traffic to flow without any interruption underneath the structure (Curtis 1996, 175-178). This approach correlates with GDA principles that seek to transcend the conventional architectural limitations and suggest structures that are completely detached from the ground.

The common vision of reducing the physical footprint of buildings in order to preserve the ground

for nature and public spaces can be observed in both Le Corbusier's pilotis and GDA. While the usage of pilotis in Le Corbusier's work aimed at achieving a visual lightness and functional liberation of the ground, GDA evolve this idea into a more radical outcome that envisions architecture freely floating in the air. This freedom from being bounded by gravity maximizes spatial flexibility and environmental harmony.

In the mid-20th century, Buckminster Fuller explored the concept of structures that float in the air. He was considered a pioneering figure in the development of structures that span large spaces without internal supports. His invention of the geodesic dome, represented a significant advancement in the quest for architectural lightness and efficiency. The geodesic dome's hemispherical shape, composed of interlocking triangles, distributed structural stress evenly, making it one of the most efficient structures in terms of material use versus enclosed volume. In collaboration with Shoji Sadao, Fuller further expanded the possibilities of Airborne Architecture with the "Cloud Nine" project (Fig.3). The project envisioned floating habitats

consisting of enormous geodesic tensegrity spheres, each with a diameter of 1.6 km (1 mile) and capable of housing autonomous communities of several thousand people. Fuller proposed that these sky cities could drift at chosen altitudes, allowing their inhabitants to view the world from above or even migrate to different locations (Baldwin, 1997, p. 190). Another visionary architect known for his avant-garde ideas, particularly in the realm of futuristic architecture, was Georgii Krutikov. His project "The Flying City" envisioned a utopian airborne structure suspended in the air as a solution to the spatial constraints of urbanization. For him placing buildings in the sky was to enable the land to then be cultivated (Maksel, 2016). Yona Friedman's unrealized theoretical construct, "Ville Spatiale" proposed a framework of a second city, as high as 20 meters, on top of an existing one. The layout of each level would not occupy more than fifty percent of the overall structure to provide proper ventilation and light to each residence and to the city below (Cline and Carlo, 2002, p. 40).

In the late 20th and early 21st centuries, architectural endeavours have become increasingly ambitious in their attempts to appear to

defy gravity. Santiago Calatrava's Museum of Tomorrow in Rio de Janeiro (Fig.4) exemplifies this trend with its striking 75-meter overhang, achieving a sense of weightlessness through a cantilevered design. Similarly, Richard Rogers's Cantilevered Gallery, Makoto Sei Watanabe's K-Museum, and Ithra's The Link - a panoramic sky concourse connecting the two towers of One Za'abeel in Dubai (Fig.5) - demonstrate the potential of architecture to challenge conventional structural norms. Notably, The Link features the world's longest cantilever, an awe-inspiring structure that floats 100 meters above the ground, further pushing the boundaries of architectural innovation in terms of structural lightness and suspension. Other contemporary architects, such as Kazuyo Sejima, have also contributed to this dialogue with the Serpentine Gallery Pavilion, where she employed slender structural pillars that almost disappear, making the roof seem as though it is hovering effortlessly above the space below.

Another well-established Japanese architect who is known for his "surreal animated movie feel" designs, is Terunobu Fujimori. His design for the "Flying Mud Boat,"

can be perceived as a case study for architecture that is elevated off the ground (Hudson, 2012).

Many contemporary architects have attempted to visually eliminate the presence of pillars in their projects. Norman Foster's more recent work, particularly his design for the roof of Apple Park's Steve Jobs Theatre, eliminates all visible pillars, creating the effect of a hovering floating roof. Such projects collectively reflect the evolution of architectural practice towards creating structures that are visually and conceptually aligned with the principles of GDA and its pursuit of architectural forms that challenge gravity.

Similarly, Lebbeus Woods, who was one of the most innovative and visionary architects of the contemporary era, challenged traditional confines of architectural practice by imagining a world unconstrained by conventional boundaries. His Geomagnetic Flying Machines visually made manifest his exploration of "what the world would be like if we were free of conventional limits." As Woods articulated, he aimed to illustrate what could be possible if we chose to live by a different set of rules. His experimental approach aligns with



Fig.4 - "The Museum of Tomorrow" by Santiago Calatrava, Photo by Rodrigo Menezes.



Fig.5 - "The Link" of One Za'abeel, a render by Ithra Dubai, United Arab Emirates.



the principles of GDA, envisioning architectural structures liberated from the earth's surface, further pushing the boundaries of what architecture might aspire to achieve.

## THE RISING OASES SAGA: BRINGING INNOVATIVE ARCHITECTURE TO LIFE

This paper discusses the Rising Oases Saga (Fig.6) that sketches out a possible future in which there are "platforms inside the city where humans can unwire themselves from their daily restraints" (Monks, 2019). The project was first conceived in 2007 at the University of Tokyo. It has evolved to be regarded as pioneering ongoing research into GDA (Alsammarae, 2019). The Rising Oases consist of sanctuaries of well-being, ethereal retreats that float above their context, offering a refuge from the frenetic pace of urban life. The aim is to allow visitors to reconnect with nature and find inner tranquility. Unlike traditional buildings, the Rising Oases are not grounded in the earth; but are aerial retreats, floating above the cityscape or the natural landscape. The project, proposes a model where

architecture coexists with, rather than dominates, it's environments.

Since 2018 the Rising Oases have been exhibited in various forums from Venice to Dubai (Fig.7). The most notable prototype - the River Prototype - showcased at the Dubai Design Week in 2019. This project garnered international attention, including coverage by CNN, for its innovative approach to architecture (Monks, 2019). The Spring Prototype was one of the earliest publicly exhibited models advocating for the architectural discipline to defy gravity and ascend, urging it to advance in line with the technological and conceptual innovations of the current era (GAA 2018, 372-373).

The Rising Oases symbolise a proposal for a new way of living, where humanity's creations float above the earth, leaving the ground free for nature to reclaim. This initiative aligns with broader trends in sustainable futurism, advocating for reduced land consumption and minimizing environmental impact. Advancements in any field of study are dynamic and continually evolving through an iterative process of exploration and refinement. Although GDA aspires to defy gravity, it remains bound by the progression of time and technological innovation. The

primary challenge of the research was to conceptualize and develop a fully self-sustaining architectural form that liberates itself from the earth and achieves equilibrium in the air. Historically, the application of such avant-garde concepts was impeded primarily by technological limitations. However, recent technological advancements have shifted this paradigm, enabling the exploration of GDA in unprecedented ways. The findings from this research indicate that, though many factors play significant roles, the stability and success of Airborne Architecture hinge on three interrelated components: design, technology, and materiality. Beyond the architectural composition and form, a crucial aspect is achieving equilibrium by managing the interplay between dead load (the intrinsic weight of the structure) and live load (the dynamic weight it must support). This necessitates the use of lightweight materials that maintain structural integrity while being robust enough to support the architecture's levitation. Thus, the materials and technologies employed must be sufficiently advanced to counteract the weight and allow the structure to float. Several practical concerns arose during the development process, such as ensuring accessibility to floating platforms, efficient water distribution, and

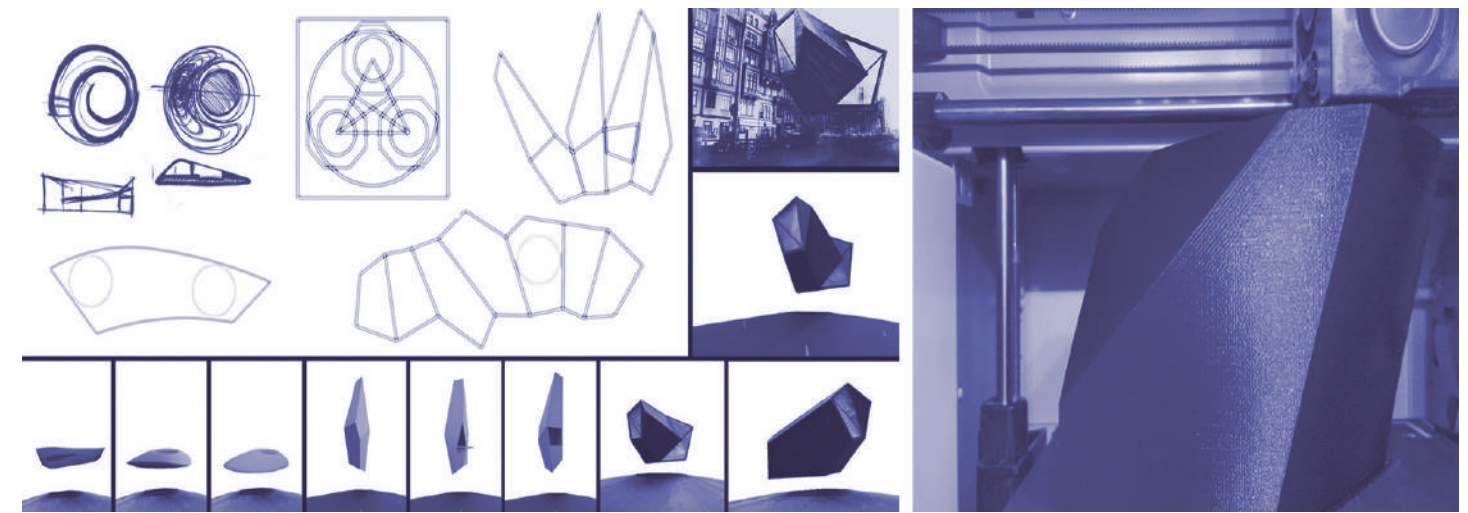

Fig.8 - Design Process & Iterations (Left) and 3D-Printed Material of the Prototypes (Right).

wastewater drainage. These were seen not as insurmountable obstacles but as stimulating challenges to be creatively addressed. Key aspects essential to the successful realization of GDA, which are deeply interconnected, include the following:

**Technology:** Various technologies are under consideration to achieve levitation, including electromagnetic suspension, superconductivity, and unmanned aerial vehicle (UAV) systems. The technologies at hand relates to existing applications such as but not limited to maglev trains or UAVs that can maintain stability in the air without any human intervention. Of course, with the advancement of these types of technologies the

capacities to levitate larger and heavier structures will improve. The current research has utilized electromagnetic levitation devices for its prototypes that are known by "Octo88" that allows levitation of 88 mm and up to a weight of 10 Kg.

**Design:** The form, function, and structural elements are fundamental to creating a self-sufficient architectural entity that achieves both aesthetic and functional balance in the air. The design must integrate principles that allow for levitation while maintaining the desired aesthetic and operational effectiveness (Fig.8).

**Size:** The scale of the project determines the type and feasibility of the architecture. It directly

influences the overall weight of the structure and, consequently, the strength and type of technology required to achieve levitation. Early prototypes were developed on a miniature scale, measuring approximately 10 centimeters (4 inches) in length and weighing around 20 grams. Over time, these prototypes have been progressively scaled up. The most recently exhibited model that occurred just before Covid measured nearly 2 meters (7 feet) in length and weighed 2000 grams. Future iterations aim to further increase in size and scale, potentially utilizing different technologies to accommodate the additional dimensions.

**Materiality:** The search for suitable materials is critical, focusing on those that are light yet rigid enough to withstand both natural forces and human use. Material choice directly impacts the visual appearance, structural weight, and overall integrity of the project, determining how minimal the architectural elements can be while still ensuring stability. The research has explored a range of materials, beginning with paper and cardboard, progressing to 3D-printed ultra-light plastic filaments (Fig.8), and currently experimenting with carbon fiber, known for its strength-to-weight ratio and rigidity.

**Weight:** The balance between dead load and live load is crucial for determining the feasibility of the structure to float. The dead load includes the intrinsic weight of the structure, while the live load



Fig.6 - "The Rising Oases Saga" (Spring, River, and Waterfall Prototypes) photo by Georges Kachaamy.



Fig.7 - The Spring Prototype Exhibition in Venice (Top) and The River Prototype Exhibition in Dubai (Bottom).





Fig.9 – “The Rising Oases Saga” (Waterfall Prototype) Exhibition in the Virtual Realm.

refers to the dynamic weight it must support. This balance directly affects the plausibility of maintaining altitude and the hovering height that the structure can achieve, given the available technological capabilities.

While the aforementioned elements are not exhaustive, they are among the most critical factors influencing the development of GDA. These factors are inherently interconnected and interdependent, requiring a holistic approach. The architect, in this context, assumes the role of a researcher who synthesizes these various elements, guiding the project toward equilibrium, and ultimately enabling the structure to become airborne.

Through iterative experimentation, diverse materials have been explored, beginning with paper and cardboard, progressing to 3D-printed ultra-light plastics, and the work is currently focusing on carbon fiber for its superior strength, rigidity, and lightweight properties. This ongoing process illustrates the continuous evolution required to achieve the ambitious objectives of GDA.

In 2020 and 2021, as part of the ongoing "Rising Oases Saga," the "Waterfall Prototype" (Fig.9) advanced into the virtual realm by employing immersive technologies to enable users to experience GDA at a full-scale, 1:1 model. This innovative step utilized virtual platforms such as Sansar and was exhibited at Palazzo Mora during the Venice 2021 Architecture Biennale to reflect the potential and significance of immersive experiences for engaging with airborne structures (ECC 2021, 124-125). Virtual Reality (VR) and Augmented Reality (AR) offer a

unique advantage in simulating GDA by allowing gravity to be effectively neutralized, thus providing users with a realistic sense of how they might interact with such spaces in the physical world. These technological tools are significant in the way that they can test and visualize spatial dynamics and user experiences within a gravity-defiant environment. In this context the use of VR and AR has demonstrated the technological possibilities for future architectural endeavours and has highlighted the importance of virtual environments as experimental grounds for innovative architecture that challenges conventional limitations usually imposed by gravity.

These digital tools and immersive technologies facilitate new understandings of architectural space and prepare designers and users for a future where GDA structures may become viable. The virtual representation of the "Waterfall Prototype" served as



Fig.10 – “GDA” soaring above a natural context, render by @gravitydefiantarchitecture.

a simulation model, and offered insights into the functional, aesthetic, and experiential qualities of GDA, and by that furthered the discourse on how technology can transform architectural design, representation, and experience.

## ENVIRONMENTAL STEWARDSHIP AND ETHICAL IMPERATIVE IN AIRBORNE ARCHITECTURE

One of the captivating aspects of Airborne Architecture lies in its potential to address the pressing environmental challenges of our time. Paul Dobraszczyk, in his book "Future Cities: Architecture and the Imagination," offers an exploration of the "Flood" scenario where rising sea levels, due to the melting of polar ice, herald a future that is shaped by dystopian events. Certainly, the concept of a "great"

flood is not novel and has populated human history through legends, myths, and stories, making it part of our collective consciousness. Specifically, in his section titled "Unmoored Cities," he changes the focus from mere mitigation to adaptation where he suggested ways in which urban environments might acclimatise to this existential threat of climate change. He identifies three strategies: the drowned, the floating, and the airborne that aligns closely with the principles and aspirations of GDA. He then further elaborates on the airborne scenario in the works of Tomás Saraceno and its significance in representing what a city in the sky might look like, and how one might live in them (Dobraszczyk 2019, 77-104). In addition, deforestation, loss of biodiversity, and the degradation of natural habitats in the 21st century has foregrounded the consequences of unchecked urbanisation. When liberating buildings from the ground, GDA reduces the physical footprint of urban development, which might act to preserve valuable ecosystems by minimizing human encroachment on natural habitats (Fig.10).

Aligned with the principles of environmental stewardship, this approach advocates for a built environment that exists in harmony with the earth's ecosystems. Furthermore, it promotes qualities essential to biophilic cities by facilitating the creation of additional green spaces within urban environments, and by contributing to the connection between human habitation and nature. These qualities could play an important role in developing biodiversity, improving air quality, and enhancing both mental and physical well-being, which are fundamental for building resilience and sustainable urban areas that prioritize human-nature interaction (Beatley 2010, 45-53).

Many studies have demonstrated that reduction of carbon emission in architecture can occur through the minimization of land use and the incorporation of renewable energy sources such as solar panels, and wind turbines. According

to the "Global Status Report for Buildings and Construction 2019," by the International Energy Agency's (IEA), the buildings and construction sector was responsible for 39% of global energy and process-related CO2 emissions. Through energy efficiency, renewable energy integration, and reduced material use, sustainable architectural practices can minimize environmental impact. The report promotes the pressing need for the decarbonization of the building sector, which requires adopting policies and technologies that promote sustainable architectural designs.

GDA promotes airborne development that plays a role in decreasing the physical footprint of buildings and the efficient usage of land which often requires significant energy and resources to construct and maintain. As a result, the restoration of natural habitats could foster ecological resilience and offer a platform for biodiversity enhancement.

Moreover, to enhance the environmental credentials of GDA and demonstrate its commitment to sustainable futurism, solar cladding panels, wind turbines, and other renewable energy systems can be seamlessly incorporated into the design to ensure that they would operate with minimal carbon emissions.



Fig.11 – “GDA” soaring above a dense urban context, a render by @gravitydefiantarchitecture.

## DURABILITY, FLEXIBILITY, AND VERSATILITY IN GDA

One of the advantages of GDA lies in its resilience, particularly, in mitigating the impacts of natural disasters. Earthquakes, floods, and rising sea levels, can easily affect buildings that are traditionally anchored to the ground. This can compromise the structural integrity of a building, lead to catastrophic failures and by that a significant loss of life. Accordingly, when structures are detached from the earth, they are less affected by these ground-based forces, and they potentially can provide a safer alternative in populated urban areas that are susceptible to these disasters. Structures that hover above the ground could be designed to endure natural hazards in an effective manner, to minimize property damage and reduce the risk to human life.

The flexibility and adaptability of structures that are not bound to the ground offer more possibilities for urban design, planning, and development in ways that conventional static architecture cannot. GDA allows the dynamic and responsive use of urban spaces. Due to its mobile nature, it can be relocated and repurposed according to the needs of the city (Fig.11).





Fig.12 – “GDA” axonometric section with isolated technical zones by @gravitydefiantarchitecture.

The value of this flexibility and adaptability can be mostly used in rapidly urbanizing areas or regions facing disasters or uncertainties such as climate change, where the importance to adjust spatial configurations, in response to socio-economical or environmental changes are crucial.

The concept of GDA is not without its challenges. Maintaining stability and balance in the face of high winds, storms, or other weather related incidences, could bring engineering and technological challenges. The requirements to ensure the safety and stability of such structures under environmental conditions would need to be highly advanced, and would require interdisciplinary collaboration between architecture, engineering, aerodynamics, artificial intelligence, and even materials science. Also, from an economical perspective, underdeveloped regions might not be able to afford the production and maintenance of such structures hindering both their feasibility and accessibility. Accordingly, while ground-based vulnerability can be avoided by GDA other technological,

economic, and logistical constraints might limit its progress and therefore must be addressed. There might be further challenges when it comes to implementation; social and cultural implications of living in these spaces could include psychological impacts or cause disruptions on established communal bonds. In addition, the possible energy consumption of these structures might also have a negative impact on the environment.

## THE PATH FORWARD: CHALLENGES AND FUTURE DIRECTIONS

While there are many compelling benefits of GDA, probably the most technologically challenging aspect is its implementation for larger scale projects. The construction and development of these flying structures would need investments in advanced technologies, materials, and infrastructures, just to state a few. In addition, the continued maintenance and operation, specifically when mobile, of these structures would incur costs, energy

consumption, and the constant monitoring of environmental and safety measures. Even in situations where these structures were static, they would still need to overcome engineering challenges of structural integrity, material limitation, energy efficiency, and of course aerodynamics when hovering in place. Emerging technologies could play a crucial role in addressing these challenges. For instance, in lightweight materials, the new developments in carbon fibre composite could provide the necessary lightweighted and structurally stable shell for GDA. Advancements in AI could also play a fundamental part in maintaining the stability of GDA when in mid-air.

Another challenge is the impact of certain technologies on human health, both physically and psychologically. For example, the usage of levitation technologies, such as, but not limited to, electromagnetic fields may be harmful to the human body. Solutions therefore would need to be found such as creating isolated technical zones that would functionally serve the levitation purpose of GDA and at the same time avoid causing any physical damage to the occupant (Fig.12). Research would also be needed into the human experience of these aerial environments to study the psychological effect of airborne societies inhabiting GDA. Other aspects related to social and economic implications would need to be considered specifically when it comes to integration into an existing urban fabric. These integrations would need innovative solutions to land use policies and its allocated air space above. Road and transport regulations would also need to be revised to include the safe and secure movement of these structures. There could also be challenges around access and equity.

There is no doubt that many challenges would need to be investigated and studied in order to ensure an adequate framework and infrastructure for these airborne habitats. For GDA to meet the needs and aspirations of diverse

communities including the future airborne societies, the involvement of all stakeholders and policymakers across many disciplines would be necessary to ensure the feasibility and sustainability of these future environments.

## EMBRACING THE VISION OF GRAVITY DEFIANT DESIGN

As we contemplate future environments, GDA and the Rising Oases Saga offer a glimpse of what might be possible when we dare to dream beyond the constraints of the ground. These innovative concepts challenge us to rethink the very nature of architecture, pushing us to explore new heights - literally and figuratively. In doing so, they open up a new horizon for architecture, one where our buildings no longer dominate the earth but coexist with it in a delicate balance (Fig.13). GDA with its emphasis on sustainability, resilience, and artistic freedom, represents more than just a technical or aesthetic innovation; it is a philosophical statement about the role of architecture in the modern world. It asks us to consider how we can build in ways that respect our planet, nurture our communities, and inspire future generations.

As a last thought, architecture throughout its evolution has



Fig.13 – “GDA” soaring above a natural context, a render by @gravitydefiantarchitecture.

crawled out of caves, settled on grounds, surfaced on water, climbed on pilotis and danced (GAA 2018, 372-373). It has even cantilevered into the air, yet it has never taken flight. The time has come to populate the skies, liberate the ground, and restore nature to its rightful place on our planet. In the end, GDA must not be looked upon as merely a vision of the future; it must be considered as a call of action for architects, engineers, explorers, and thinkers to embrace the possibilities of a world where our environments can take flight. As we embark on the challenges and opportunities of this century, GDA takes a bold and inspiring vision of what our cities could become.

## BIBLIOGRAPHY

Alsammarae, Rima. AUD chair of architecture proposes design for floating building. Dubai: Middle East Architect, 8 April 2019. Accessed 1 Sep 2024. URL: <https://www.middleeastarchitect.com/insight/42723-aud-chair-of-architecture-proposes-design-for-floating-building>

Anderson, Glair D. (2024). A Bridge to the Sky: The Arts of Science in the Age of 'Abbas Ibn Firnas. Oxford: Oxford University Press. <https://doi.org/10.1093/oso/9780190913243.003.0005>

Baldwin, J (1997). BuckyWorks: Buckminster Fuller's ideas for today. John Wiley and Sons. p. 190. ISBN 978-0-471-19812-3.

Beatley, Timothy. Biophilic Cities: Integrating Nature into Urban Design and Planning. Washington, D.C.: Island Press, 2010. ISBN: 978-1597267151.

Cline, Bevin and Carlo, Tina di, in Terence Riley, ed. The Changing of the Avant-Garde: Visionary Architectural Drawings from the Howard Gilman Collection, New York: The Museum of Modern Art, 2002. Accessed 26 Oct 2024. URL: <https://www.moma.org/collection/works/104695>

Curtis, William J.R. Modern Architecture Since 1900. London: Phaidon Press, 1996. ISBN: 978-0714833569.

Dobraszczyk, Paul. Future Cities: Architecture and the Imagination. London: Reaktion Books, 2019. ISBN: 978-1789140373.

GAA Foundation (2018). Time Space Existence. Venice: GAA Foundation, 2018. Accessed 14 Sep 2024. URL: <https://europeanulturalcentre.eu/var/gallery/file/327ffa108e30d56f4676b1edf29c96a8.pdf>

European Cultural Center (2021). Time Space Existence: Venice 2021 Architecture Biennale. Venice: European Cultural Center, 2021. Accessed 9 Sep 2024. URL: <https://ecc-italy.eu/var/gallery/file/16250579e1ca5aa92951327efdc51eb4.pdf>

Frampton, Kenneth. Modern Architecture: A Critical History. Fifth Edition. London: Thames & Hudson, 2020. ISBN: 9780500204443.

Hudson, Danny. Terunobu fujimori: flying mud boat. Milan: Designboom Magazine. Accessed 14 Sep 2024. URL: <https://www.designboom.com/architecture/terunobu-fujimori-flying-mud-boat/>

International Energy Agency (2019). Global status report for buildings and construction 2019. IEA. United Nations Environment Programme, 2019. Accessed 8 Sep 2024. URL: <https://www.iea.org/reports/global-status-report-for-buildings-and-construction-2019>

James, Simon J. (2012). Maps of Utopia: H. G. Wells, Modernity and the End of Culture. Oxford: Oxford University Press. <https://doi.org/10.1093/acprof:oso/9780199606597.003.0004>

King, Ross. Brunelleschi's Dome: How a Renaissance Genius Reinvented Architecture. New York: Penguin Books, 2000. ISBN: 978-0142000151.

Maksel, Rebecca. The Soviet City in the Sky: In 1928, a Russian architect proposed taking urban living to new heights. Washington, D.C: Smithsonian Magazine: Air and Space Magazine. Accessed 14 Sep 2024. URL: <https://www.smithsonianmag.com/air-space-magazine/soaring-city-180957990/>

Monks, Kieron. Rising Oases project imagines a city of airborne architecture. Atlanta: CNN Style, 13 November 2019. Accessed 1 Sep 2024. URL: <https://edition.cnn.com/style/article/levitating-architecture-dubai/index.html>

Trachtenberg, Marvin, and Hyman, Isabelle. Architecture: From Prehistory to Postmodernity. New York: Harry N. Abrams, 2002. ISBN: 978-0130907865.



# Transformative Technologies in Architectural Design

## Revolutionising the Built Environment

mimari tasarım  
parametrik tasarım  
artırılmış gerçeklik (AR)  
3D modelleme  
simülasyon araçları  
architectural design  
parametric design  
augmented reality (AR)  
3D modelling  
simulation tools

Bu çalışma, çağdaş mimaride ortaya çıkan tasarım teknolojilerinin, dönüştürücü teknolojilerin mimari tasarım üzerindeki etkisi yoluyla fiziksel formları nasıl yeniden şekillendirebileceğini ve bunların yapılı çevrede devrim yaratma potansiyelini araştıracaktır. Bu araştırma, müşteriler, tasarımcılar ve genel olarak toplum arasında tasarım verimliliğini artırmak için yeni umutlar açmayı ve mimari tasarımın geleceğini şekillendirmede teknolojinin dönüştürücü gücüne dair içgörüler sağlamayı amaçlamaktadır. Gelişmiş 3D modelleme ve simülasyon araçları, mimarların fikirlerinin sanal temsillerini oluşturmalarına ve bunları son derece gerçekçi bir şekilde keşfetmelerine olanak tanıyarak tasarım sürecinde devrim yarattı. Bir başka dönüştürücü teknoloji olan parametrik tasarım, mimarların daha önce başarılması zor olan karmaşık ve dinamik mimari formlar yaratmasına olanak tanır. Artırılmış gerçeklik (AR), kullanıcı deneyimini geliştiren ve tasarım iletişimini geliştiren dönüştürücü bir teknoloji olarak ortaya çıkmıştır. Bu araştırma, vaka çalışmaları ve sektör eğilimlerini inceleyerek bu teknolojilerin mimari tasarımdaki dönüştürücü gücüne ışık tutmayı amaçlamaktadır. Sonuç olarak, dönüştürücü teknolojiler, mimarların yaratıcılığın sınırlarını zorlamasını, bina performansını optimize etmesini ve kullanıcı deneyimlerini geliştirmesini simülasyon araçları, parametrik tasarım ve artırılmış gerçeklik, mimarlara keşif ve yenilik için yeni yollar sunuyor. Mimarlar bu teknolojileri benimseyerek yapılı çevrenin geleceğini şekillendirebilir, gelecek nesiller için sürdürülebilir, verimli ve ilgi çekici alanlar yaratmak için araştırma yapabilir.

This study will explore how emerging design technologies in contemporary architecture might reshape physical form through the impact of transformative technologies on architectural design. Our research aims to open up new prospects for improving design efficiency between clients, designers, and society at large and provide insights into the transformative power of technology in shaping the future of architectural design. Advanced 3D modelling and simulation tools have revolutionised the design process, allowing architects to create virtual representations of their ideas and explore them in a highly realistic manner. Parametric design, another transformative technology, will enable architects to develop complex and dynamic architectural forms that were previously challenging to achieve. Augmented reality (AR) has emerged as a transformative technology that enhances the user experience and improves design communication. Through examining case studies and industry trends, this research aims to shed light on the transformative power of these technologies in architectural design. In conclusion, transformative technologies have revolutionised architectural design by enabling architects to push the boundaries of creativity, optimise building performance, and enhance user experiences. Advanced 3D modelling, simulation tools, parametric design, and augmented reality offer architects new avenues for exploration and innovation. By embracing these technologies, architects play a crucial role in shaping the future of the built environment, researching to create sustainable, efficient, and engaging spaces for generations to come.

**Atakara, Cemil<sup>1</sup>; Kalwry, Hasan<sup>2</sup>**

<sup>1</sup> Cyprus International University, Architecture Department, Faculty of Architecture, Lefkosa, Northern Cyprus, Turkey. catakara@ciu.edu.tr

<sup>2</sup> Cyprus International University, Architecture Department, Faculty of Architecture, Lefkosa, Northern Cyprus, Turkey. Hasan.kalwry@gmail.com

Citation: Atakara, C.; Kalwry, H. (2024). "Transformative Technologies in Architectural Design", UOU scientific journal #08, 144-155.

ISSN: 2697-1518. <https://doi.org/10.14198/UOU.2024.8.14>

This document is under a Creative Commons Attribution 4.0 International license (CC BY 4.0)

Article Received: 15/09/2024  
Received in revised form: 10/11/2024  
Accepted: 20/11/2024





## INTRODUCTION

Architects have used technology in numerous capacities in their design processes. Technology has been seen to simulate reality, creating a closed loop and using performance analysis to enhance project quality. While visual simulations can provide insights into project orientation and perceptions, performance analysis can investigate ways to maximise the environmental virtues of structures (Sabin, 2015). Architects, as the driving force behind the daunting tasks of rebuilding and revitalising nations, have not shied away from embracing modern techniques and the possibilities of emerging technologies. Their proactive approach and willingness to adapt and innovate have been instrumental in the evolution of the architectural landscape, inspiring others in the industry with their forward-thinking and adaptability.

This research explores the transformative potential of emergent digital technologies in building design. These technologies are not just enabling spatial possibilities for architectural practice but also transforming how we rethink, redesign, and ultimately construct a more liveable, sustainable, resilient, and culturally enhanced built environment of the future. This transformation offers a hopeful vision for the future of architecture, instilling a sense of optimism in the audience about the positive changes these technologies can bring (Hajirasouli et al., 2022).

One of the more transformative technologies reshaping the design of our built environment is digital 3D modelling and simulation that supports the designer in the conception, visualisation, and communication of design intent. For example, Revit or ArchiCAD supports the visualisation and form-finding process. It allows architects to create a vibrant and accurate 3D model of a building, which is interactive, collaborative, and transparent among the design team. This enables architects to develop virtual walkthroughs or a reflective simulation of the built outcome as the design evolves. For example, the

design of a large complex building with floors and hundreds of internal spaces as a virtual simulation before construction begins, which alerts the design team to potential discrepancies or design issues and helps to optimise and facilitate design intent, thus reducing errors in construction (Pey et al., 2020).

Parametric design, a technology that has revolutionised the architectural profession, involves using algorithms to create complex, multidimensional, and dynamic architectural forms. These forms are generated iteratively, with parameters defining relationships and constraints in a design and possible multiple iterations of a parameter between an upper and a lower variation limit. In simpler terms, parametric design uses computer algorithms to create unique and complex architectural designs (Gaggioli, 2016). Parametric modelling usually promotes efficiency and flexibility and helps the architecture profession apply more sustainability in design and construction processes. With its critical design criteria and incorporation of algorithms, this approach instils confidence in the profession's ability to select the optimum form to explore. For example, algorithms help optimise a building's orientation regarding solar radiation or the prevalent wind direction. Super-fine tuning of an optimum form can maximise the potential for using passive heating in buildings and minimise building energy consumption, ensuring sustainable outcomes (Gaggioli, 2016).

Another virtual-physical crossover in architectural practice is augmented reality (AR), the immersive display environment that situates a design model in real-world space. AR has been used for years in immersive design presentations, which are presentations that allow clients, stakeholders, and the public to experience a design as if they were physically present in the space (Gaggioli, 2016). Trade shows and design expos have showcased buildings sporting AR labels and information panels when seen

through a smartphone equipped with an AR app. Practical application of this technology can significantly increase comprehension and communication between all parties involved. AR has also improved design collaboration between architects, civil, electrical, mechanical engineers, and contractors. It enables many team members to work on and review the same model, improving decision-making and delivering more excellent value on projects.

BIM is a shift in thinking and calls for architectural and engineering firms to join forces. This collaborative approach, where everyone has a shared understanding of the project, offers facilities managers, engineers, and architects better control of data and information and streamlines the design and construction process. It is a testament to the value of teamwork in the design process, highlighting the importance of collaboration in achieving successful architectural projects (Shen et al., 2024). The intelligent 3D model, a key component of BIM, is then used throughout the project lifecycle by all collaborators in a way only possible before with informational silos. It is a comprehensive, single system of record that promotes quality, reduces waste, and helps in cost control. It gives everyone a shared understanding of the information as it evolves and promptly helps resolve conflicts during and after the design phase. By reducing redundant data, BIM streamlines and optimises the design production process, facilitating the connection between design, engineering, and construction.

The payoffs for using BIM can be enormous: costs can be reduced, construction projects can be completed faster, and the design process becomes more efficient (Mackintosh, 2018). How can we use AR and VR to produce more realistic digital assessments of client proficiency? What if we embedded virtual problem-solving tasks through a computer BIM environment?

## AIMS AND OBJECTIVES

This research will explore transformative technologies' disruptive potential and influence on the future of architectural practice and design. It will do so through in-depth case studies and an overview of the latest trends in the industry. The research will identify how architects use these technologies to improve their buildings' ecological and environmental qualities, increase the responsiveness of their approach to design, and enhance users' experiences of the built environment. This emphasis on the role of technology in improving the ecological and environmental qualities of buildings will also highlight the role of technology in the quest to revive the city by taking advantage of new tools and practices to detect, understand, and activate its latent and unexploited potential. Similarly, it will discuss the challenges, speculations, and limitations of their integration into a multitude and diverse range of architectural practices. It will thus highlight the potential of these tools to empower architects worldwide to design and build a more sustainable, culturally sensitive, and aesthetically inspired future for built environments worldwide. Future practice and design will continue to utilise cutting-edge technology to redefine the perception of architecture as a suitable life habitat that integrates the socio-cultural context with our rapidly changing environment. The following objectives were formulated:

- Analyse applications and benefits of Transformative Technologies in Architectural Design.
- Assess the challenges associated with technological infrastructure, cost, and cultural adaptation.
- Develop recommendations for promoting the adoption of these technologies.
- Examine how these technologies can contribute to a more resilient, sustainable, and culturally significant built environment.

## METHODOLOGY

### RESEARCH DESIGN

A comprehensive qualitative literature review analysis has been undertaken to study the transformational imprints in architectural design through the leading-edge evolution of technologies. This analysis, which involves synthesising published materials, is crucial in reinforcing the profound outcomes amassed through the literature review on the imminent disruption in architecture owing to the amalgamation of advanced 3D modelling, simulation tools, parametric design, augmented reality (AR), and building information modelling (BIM). The comprehensive review, a key source of information, provides us with a deeper understanding of the future of architecture and the role of technology in shaping it, thereby making our audience feel more informed and knowledgeable.

### DATA COLLECTION

This data comes from various academic sources, such as books, peer-reviewed journal articles, conference papers, and credible industry reports. The article reviews the literature linked with the research questions, stressing its scientific plausibility. It has been published recently so that current and influential studies are covered. Various databases, such as Google Scholar, JSTOR, ScienceDirect, and IEEE Xplore Digital Library, were meticulously used to obtain the literature, ensuring a comprehensive and reliable data collection process.

### DATA ANALYSIS

Data analysis was done using the narrative method, a qualitative research approach that follows the main themes and most significant findings extracted from the selected literature throughout the process. This method allows the audience to feel engaged and connected to the research process, providing a clear and structured way of interpreting the data. Narrative analysis is a way of distinguishing meaning from a vast database through a

series of stages: familiarisation with data, identification and coding information into thematic categories, and finally, synthesis of the themes into a narrative. The following analysis interprets the trajectories of technological transformations in architectural design and practice as an interpretative narrative. The narrative is built around ideas from various sources. It addresses the pros and cons of three-dimensional (3D) modelling and simulation tools, parametric design, augmented reality, and building information modelling analysis advancements.

### FINDINGS

#### TRANSFORMATIVE TECHNOLOGIES IN ARCHITECTURAL DESIGN

##### ADVANCED 3D MODELLING AND SIMULATION TOOLS

According to Bijl and Boer (2011), many leading international architectural practices use 3D modelling and simulation tools that have drastically changed how the building is designed and how the architect's vision informs clients. The present-day super-architects could not work, nor would they be, without the capability to produce the most accurate and convincing 3D virtual representation of the building that has ever existed. These new procedures in how architects design the built environment have created higher collaboration and openness in architectural design. These powerful software applications allow them to build on the 2D drawings by immersing them in 3D models that express design complexity (Mohorko et al., 2008). Revit uses Building Information Modelling (BIM) processes that embed an intelligent model that collects, beyond the geometric model of the building, the structural elements, the materials, and the MEP systems involved. This data can be used to create virtual walkthroughs and simulations in four dimensions of time. All of this contributes to a clearer idea of the intent of the design while assuming its production from the model. Furthermore, with its varied and advanced functionalities, this tool facilitates a better exchange and





Fig.1 - Shanghai Tower Building in China (Source URL 1).

collaboration between the designer and the client. It fosters enhanced teamwork within the architectural office, making everyone feel more involved and valued (Rohani et al., 2014).

The ability to visualise a project in its entirety at the project's inception brings numerous benefits. 3D modelling, in particular, plays a pivotal role in early issue identification and resolution, thereby enhancing project design accuracy and cost efficiency. For instance, in constructing the Shanghai Tower in Shanghai, China, 3D modelling and simulation were instrumental in resolving significant issues related to structural integrity and ambient environmental conditions for

this 127-floor supertall structure and its integration with the urban environment. This early identification of issues reassures the architects and the clients about the accuracy of the design process (Fig.1) (Vajta & Juhasz, 2005).

In addition, large infrastructure projects were being crafted with sophisticated 3D modelling. The Crossrail scheme in London used BIM to help synchronise the project's multiple designers and constructors. As well as acting as an aide to improve collaboration, using the software also helped minimise construction risks and costs (Liu et al., 2008). However, even advances in these technologies have hindered their use. The limited availability of broadband communication

and complex technical skills, such as proficiency in software like Revit, ArchiCAD, and 3ds Max, are just a few barriers preventing the widespread use of these developments. 3D visualisations and digital simulation tools are pivotal to bringing new ideas to the architectural world, speeding up client communication, and developing projects that will allow the urban scope to be rejuvenated and upgraded into modern society (Abo-Elnor et al., 2004) (Tab.1).

The meta-analysis of the critical studies shows how the convergence of 3D modelling and simulation tools facilitates a new paradigm concerning how the architectural project is designed and visualised and how the client's requirements

can be communicated and improved. Tools such as Revit, ArchiCAD, and 3ds Max have enabled building owners and tenants to visualise the design in greater detail, allowing a more accurate and realistic evaluation (Abo-Elnor et al., 2004). This has also facilitated the project's effective coordination between the client and contractor teams. Such tools have accelerated innovation and transformation in recent years; for instance, Revit and its use of BIM principles have revolutionised architectural practice. They have allowed for the inclusion of building data, such as structural elements, materials, MEP (mechanical, electrical, and plumbing) systems, and others. This feature is crucial for building infrastructures, such as large-scale infrastructure projects, including London's Crossrail – a new high-speed rail line. BIM only became mandatory for the Crossrail project in 2009, but it proved to assist cooperation, reduce risks, and save costs by 13 per cent. Creating realistic walkthroughs and 'flythroughs' of the designed outcomes has also increased client perception and satisfaction.

This is especially the case for visualisation tools like Lumion, Unity, V-Ray, and the Enscape plugin, which allow users to create

realistic daylight images of indoor spaces. The colour choice and brightness of rooms and the visual aspects of furniture, lighting, and acoustics can be evaluated. These designs, such as in mixed-use developments and educational facilities, result in client approval and satisfaction. Tools that integrate BIM software for generating virtual walkthroughs have also been highly influential in complex structural and environmental challenges, as shown by the Shanghai Tower in Shanghai, China, which won the 2015 CTBUH Award for the world's 'tallest' building based on soft soil.

## PARAMETRIC DESIGN

According to Monedero (2000), parametric design algorithmic and parameter-based design methodology that generates complex forms, efficiently optimises design solutions, and integrates sustainable design strategies with innovative shapes and possibilities - is expected to become the standard for a vast range of buildings around the world and fundamentally transform how designers will generate design solutions for generations to come (Roland Hudson, 2010). The parametric design allows architects to specify relationships and constraints, creating a dynamic system capable

of generating variations and optimising according to specific criteria.

Parametric design is a departure from the static, top-down architectural design process. The architect literally 'draws' out a building and instead adopts a more flexible, data-driven bottom-up approach that emphasises generating possibilities and multitudes of forms in an iterative design process (Monedero, 2000).

Perhaps one of the most crucial uses/results of parametric design in architectural practice and production is the creation of rigorous and sophisticated architectural forms that, using traditional methods, would result in an excessive amount of planning and labour or perhaps be impossible to achieve (Eltaweel & Yuehong, 2017; Roland Hudson, 2010), using algorithms, architects can create intricate geometries, dynamic curvatures, and fluid patterns, allowing built landscapes to respond to external systems and data streams while taking advantage of the emerging aesthetic of these architectural forms to create sophisticated and beautiful buildings. For instance, the fluid, muscular forms of the Heydar Aliyev Center in Baku, Azerbaijan, designed by Zaha Hadid Architects, were realised through the employment of parametric design techniques, creating a seemingly effortless pneumatic, multifaceted, and dynamic building (Fig.2) (Gu et al., 2021).

Aside from aesthetic innovation, parametric design is a valuable tool for optimising design efficiency and sustainability parameters, as the code or design parameters (e.g., energy, daylighting, and proportional strength) can be defined. The algorithms are then used to specify the design variations index of that parameter – effectively creating a more efficient and sustainable outcome. Schumacher (2015) argued that a parametric design could influence a building's orientation and geometry to maximise the amount of solar gain in winter while minimising

STUDY	TOOLS USED	KEY FINDINGS	APPLICATIONS	IMPACT
Bijl and Boer, 2011	3ds Max, Revit, ArchiCAD	Modelling, improving design accuracy and collaboration. This emphasis on collaboration makes the audience feel more connected and engaged in the design process.	Residential and commercial architecture	Enhanced design precision and stakeholder communication
Mohorko et al., 2008	Revit (BIM)	BIM integration fosters comprehensive data management, including structural elements, materials, and MEP systems.	Infrastructure projects, urban planning	Improved project coordination and reduced construction errors
Vajta and Juhasz, 2005	Revit, VR simulations	Virtual walkthroughs and immersive simulations enhance understanding of design intent.	Mixed-use developments, educational facilities	Increased client engagement and satisfaction
Liu et al., 2008	Customised 3D modelling software	Addressed complex structural and environmental challenges in skyscraper design.	Shanghai Tower, China	Successful integration with urban fabric, enhanced sustainability
Abo-Elnor et al., 2004	BIM	Extensive use of BIM for design and construction coordination in a large-scale infrastructure project.	Crossrail project, London	Improved collaboration reduced risks and costs

Table 1 - Advanced 3D Modelling and Simulation Tools.





Fig.2 - The Heydar Aliyev Center (Source URL 2)

the amount of solar heat gain in summer, meaning the building would require less artificial cooling to create a comfortable interior environment. This can help maximise energy use and reduce the lifecycle environmental impacts of a building. The Al-Bahar Towers in Abu Dhabi effectively used a responsive facade system that shades its surfaces depending on the intensity of sunlight, eliminating the unnecessary use of artificial cooling systems, maximising energy efficiency, and demonstrating the potential of parametric design (Fig.3).

Sustainable design strategies can be embedded as parameters so that architects can look at design options that use more sustainable materials, minimise our energy footprint, and reduce the amount of waste we produce. An example is how parametric designers develop increasingly sophisticated

facades incorporating renewable energy sources to optimise natural ventilation and integrate green building technologies. This helps to create a sustainable, environmentally responsible approach to designing. For instance, at the Bullitt Centre in Seattle, dubbed the greenest commercial building in the world, how its energy systems can be optimised was embedded as a parameter to achieve net-zero energy (Roly Hudson, 2008). However, while parametric design still grows globally, its potential is vast. The possibilities to generate complex forms, optimise design parameters, and incorporate sustainable strategies offer a distinctive opportunity to design more innovative, efficient, and sustainable buildings in the developing world, which faces many environmental and economic challenges (Chokhachian, 2014) (Fig.4).

Several international case studies have shown that the power of parametric design can lead to truly innovative, sustainable architectural solutions. An excellent example is the Morpheus Hotel in Macau, designed by Zaha Hadid Architects. A free-form exoskeleton that markedly maximised structural efficiency, material performance, and structural geometry was developed through parametric design (Fig.5). It resulted in a fascinating, iconic, and, at the same time, efficient, sustainable building (Romaniak & Filipowski, 2018). Arguably one of the most ambitious and innovative projects to have utilised solar technology so far, One Central Park in Sydney combines parametric design with vertical gardens and a cantilevered heliostat that reflects sunlight into the surrounding areas, helping to boost urban biodiversity and reducing energy use (Na, 2021).



Fig.3 - Al-Bahar Towers in Abu Dhabi (Source URL 3).

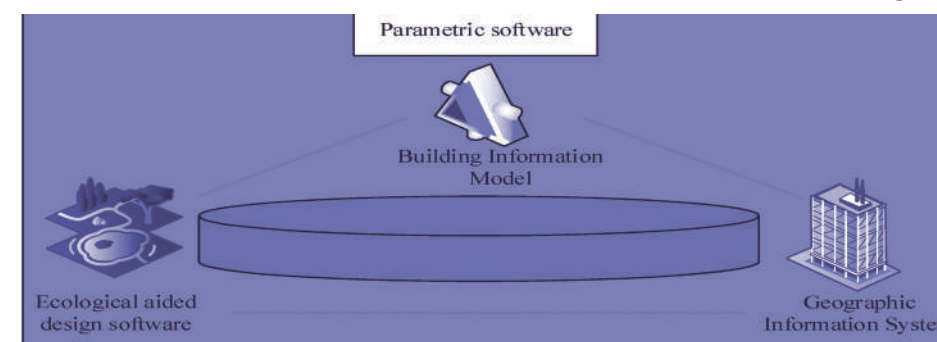

Fig.4 - Parametric Software (Source Han. et al., 2023).



Fig.5 - Morpheus Hotel in Macau, China (Source URL 4).

The parametric design owes its progress to numerous factors, the most salient of which is the continued parametric design process, which can lead to the future of architecture being real, worldwide, and sustainable (Wortmann & Tunçer, 2017) (Tab.2).

## AUGMENTED REALITY (AR)

On the other hand, the arrival of Augmented Reality (AR) technology (digital information overlaid onto the real world) has led to its use in the wider architectural field, a change of course that threads through the whole process of how architects present their work to both the client and their colleagues they argued that applications in architecture are equally varied and impactful (Chi et al., 2013) AR is a tool and gateway to creating more compelling design presentations.



STUDY	TOOLS USED	KEY FINDINGS	APPLICATIONS	IMPACT
Khan (2024)	Grasshopper, Dynamo	Utilises algorithms to create efficient and sustainable designs	Sustainable architecture	Enhanced design efficiency and sustainability
Han et al. (2023).	Custom Parametric Software	Maximises structural efficiency and minimises material use	High-rise building design	Material efficiency and visual innovation
Naboni and Paoletti (2015)	Custom Parametric Software	Achieves fluid, undulating forms through parametric design	Iconic public building	Dynamic and iconic architecture
Ghazal et al. (2023).	Custom Parametric Software	Integrates vertical gardens and sunlight reflection systems	Urban residential complex	Urban biodiversity and energy efficiency
Tuzun Canadinc (2022)	Grasshopper, Dynamo	Explores a wide range of design possibilities	General architectural innovation	Broader exploration of design solutions
Romaniak et al. (2018).	Custom Parametric Software	Achieves net-zero energy consumption through optimisation	Commercial building	Sustainability and energy efficiency
Rattenbury (2018)	Grasshopper, Dynamo	Optimises energy consumption and minimises waste generation	Sustainable materials and energy optimisation	Sustainable and waste-minimizing architecture
Gu et al. (2021).	Custom Parametric Software	A responsive facade reduces the need for artificial cooling	Skyscrapers with environmental adaptations	Energy savings and environmental integration

Table 2 - Parametric Design.

Architects use AR by creating virtual models of their designs superimposed onto the natural world. This process allows them to craft presentations that captivate clients, stakeholders, and the general public, offering an intuitive and visceral understanding of a building's design intent (Broschart & Zeile, 2015; Chi et al., 2013) AR is a powerful tool for clients to enhance their knowledge of a proposed design. Using an AR app to virtually 'walk' through a building, they can grasp the flow of space, the play of light, and the potential scenic views. This immersive experience deepens their appreciation of the design and fosters better communication and understanding throughout the design process (Song et al., 2021).

AR is revolutionising collaborative design processes, breaking free from the confines of the conference room. Architects, structural engineers, and construction crews can work more efficiently by overlaying a virtual model onto a natural site. This allows them to identify conflicts, visualise structural components, and make

unprecedentedly coordinated decisions. The result? A streamlined project process with minimised design errors and quality losses, boosting productivity and project success rates (Song et al., 2021).

While AR adoption is still in its infancy, there are compelling examples of AR transforming city architecture and urbanisation. The Erbil Citadel Restoration Project is one such example. This ambitious project aims to restore the historic Erbil Citadel – a World Heritage site in northern Iraq. To enrich visitors' experience, the restoration project uses AR to provide digital information about the Citadel's development throughout history, virtually experience its historical assets, and visualise the impact of the restoration design on the site as a whole. This immersive approach allows visitors better to understand the Citadel's history and cultural significance. Kensek et al (2000), with new technology, they can see what the proposal will look like in space, providing situational immersion and allowing them to evaluate how one design decision will impact the other collectively

with hundreds of different design options (Kensek et al., 2000) (Tab.3).

AR has been used globally to restore the Notre Dame Cathedral in Paris. In the wake of the devastating fire in August 2019, AR visualisations were employed in the restoration process to serve as a transparency tool for stakeholders in the rebuilding process. This allowed people to understand how the cathedral was being rebuilt and allowed experts to share their expertise. The Notre Dame AR project demonstrated that AR technology has power in transparency and the level of engagement that can be fostered in large-scale restoration projects.

Adobe system in the planning and building of Apple's new headquarters in Cupertino, California – Apple Park – AR was heavily employed during the design and construction phase to aid in visualising the proposed campus. Engineers and designers could view the ongoing project in the context of the world, which would offer greater insight for decision-making and create a more unified final product (Kensek et al., 2000).

These studies are examples of the emergence and potential of AR to communicate, collaborate, and understand architectural projects better across the globe. By dissolving the boundaries between virtual worlds and physical worlds, architecture and reality, AR allows architects to communicate their design intent, connect with their clients, and collaborate toward more intelligent, sustainable, and culturally authentic built environments (Pallasena et al., 2022).

## CHALLENGES AND OPPORTUNITIES

Embracing transformative technologies in architecture is a journey filled with potential. However, it has its share of challenges. These hurdles, which encompass technological infrastructure, cost and accessibility, and cultural and social context, are pivotal to overcome for the

STUDY	TOOLS USED	KEY FINDINGS	APPLICATIONS	IMPACT
Scholz and Smith (2016)	Custom AR Software	Enhanced immersive design presentations and client engagement.	Design presentations, client engagement	Improved communication and understanding, enhanced project visualisation
Jessen et al. (2020).	AR Apps	AR improves educational engagement and understanding.	Educational environments	Increased engagement and educational outcomes
P.randi et al. (2023)	AR Visualization Tools	AR provides a comprehensive understanding of design intent and spatial relationships.	Architectural visualisation	Better visualisation and decision-making
Dow (2008)	AR in Construction Coordination	AR reduces errors by 35% and improves project delivery times by 20%.	Construction coordination	Reduced errors and improved efficiency
Pallasena et al. (2022).	AR for Historic Restoration	AR enhances transparency and engagement in large-scale restoration efforts.	Historic restoration	Greater transparency and stakeholder involvement
Song et al. (2021).	AR for Design and Construction	AR allows informed decision-making and a cohesive final product.	Design and construction of large-scale projects	More coherent and informed project outcomes

Table 3 - Augmented Reality (AR).

progression of the field (Agerwala & Chatterjee, 2005).

Another critical challenge is reliable internet access and skilled technical expertise. While connectivity is increasing, the uneven spread of online access and speed, especially in rural areas, remains a significant bottleneck. Advanced technologies depend on reliable and fast internet connections, which are critical for accessing cloud-based software, sharing data, and leveraging online collaboration tools. The need for more skilled technical staff trained to use advanced software, data, and BIM technologies calls for substantial investment in education and training programs to equip architects and engineers with the necessary skills.

The inherent cost of acquiring and configuring cutting-edge technologies poses another insuperable problem for most practitioners and firms. Sophisticated 3D modelling software, BIM platforms, and AR applications usually involve significant investments that render

smaller firms and individual practitioners unable to join the technological race. The lack of resources will almost automatically preclude access to advanced technologies for those struggling under unfavourable economic circumstances. Accessibility-related issues also conjure up other impediments. The requirement for special hardware, for example, fancy computers and large 100-inch monitors, could throw many architectural practices operating in remote locations and hinterlands into a quandary, as such locations are not endowed with first-rate infrastructure facilities to support the adoption of such technologies. Moreover, the lack of readily available support services, such as those offered in technical training, software maintenance, and refurbishment, could create different sorts of trouble in design and innovative production (Horelli & Wallin, 2013).

They are integrating these technologies into an architectural practice's cultural and environmental challenges.

Conventional design practices tuned to local craft traditions and knowledge transfer across generations may need to evolve to consider the broader challenge of technological adoption. How can a technological approach complement existing practices rather than simply replacing them? At the same time, the social and cultural barriers to technological adoption require consideration. The culture of design and construction must be nurtured to develop a framework for an open and innovative approach towards architectural practice. Clarifying the intent behind utilising such technologies, for example, better housing for all and not just for a select few, might help bridge the understanding gap and foster a receptive, rather than a sceptical, attitude toward using emerging technologies for AEC. When stakeholders are brought together, the broader argument for accelerated technological adoption can start to make more sense, and a more straightforward path can be forged. Overcoming inertia would not be accessible in a context deeply tied, for generations, to traditional modes of design, construction, and delivery of buildings.

## ADDRESSING THE CHALLENGES

Solving these challenges will require substantial work because the luxury sector has yet to traditionally be a significant focus of government agencies, educational institutions, professional organisations, or industry stakeholders seeking to help young people in developing countries (Agerwala & Chatterjee, 2005):

- Invest in Infrastructure: Investing in internet infrastructure and providing access to fast broadband is essential for using cloud-based technologies and exploring architectural innovation.

- Building capacity for education and training: It is vital to invest in curriculum development that will equip architects and civil engineers to take advantage of transformative technologies. Such curricula at the



university level need hands-on and project-based training, close links with research and practice, and post-qualification continuing education.

- **Foster Collaboration:** A united firm comprising government agencies, universities, and professional societies is essential to creating an ecosystem that supports technological adoption. This can be achieved through shared resources, joint research projects, and the establishment of industry standards and best practices.

- **Culturally and Sociologically:** Involving architects and practitioners in an open dialogue on the potential of transformative technologies, highlighting success stories, the possibilities for innovation, and the importance of these technologies in culture and sustainability to the built environment.

These approaches can lead to more receptive and open-minded attitudes toward change, making everyone feel included and valued.

## FUTURE OF ARCHITECTURE

The new paradigms of transformation apparent in these technologies can change the future of architectural practice on a global scale, making the design and construction of the built environment more sustainable and enhancing the capabilities and benefits of a more technologically advanced future for all humankind.

Through the application of these technologies, architects across the world can help build towards a greener future through advanced working tools for energy-efficient, adaptable, and comfortable buildings designed through a comprehensive understanding of the surrounding context and in context with an extensive set of tools designed for the best use of resources and the integration of bio-literate green-building technologies.

Taking advantage of technologies designed to create more liveable

and resilient urban spaces can foster the innovation of collaborative and integrated design projects based on the principle of adaptive reuse for public spaces, transportation networks, pedestrian circulation, and smart-city solutions. A sharing and collaborative global research community involving architects, urban planners, and students in architecture and design would help further develop and integrate advanced digital tools in global architectural practice, ensuring that these tools are both cutting-edge, practical and user-friendly (Horelli & Wallin, 2013)

## CONCLUSION

As transformative technologies continue to shape the practice of architecture worldwide, the contemporary production of buildings fundamentally reshapes how architects design and build structures.

Integrating transformative technologies in architectural design, such as advanced 3D modelling and simulation tools like Revit, ArchiCAD, and 3d Max, has revolutionised the design process by enabling architects to create accurate virtual representations of buildings and improve collaboration with clients and within the architectural office. Additionally, parametric design methodologies have introduced a dynamic systems approach that generates complex forms efficiently and optimises design solutions with sustainable strategies. Augmented reality (AR) technology has enhanced design presentations, improved client communication, and facilitated collaborative decision-making in architectural projects.

In conclusion, using augmented reality (AR) in architectural design has shown significant potential to transform the field. AR has been demonstrated to enhance immersive design presentations, client engagement, and educational environments through AR apps and visualisation tools. Additionally, AR has played a crucial role in construction coordination, reducing errors by 35% and improving project

delivery times by 20% (Dow, 2008). This technology has also been instrumental in historic restoration projects, enhancing transparency and stakeholder involvement by allowing architects to overlay digital models onto the physical site, fostering informed decision-making and cohesive outcomes in large-scale design and construction projects.

Furthermore, the challenges and opportunities associated with implementing transformative technologies in architectural design were explored. From technological infrastructure and cost accessibility to cultural and social integration, these challenges present significant barriers.

Overcoming these obstacles will require substantial investment in internet infrastructure, education and training, collaboration among government agencies, universities, and professional societies, and fostering open dialogue on the potential of transformative technologies. It is important to note that while these technologies offer numerous benefits, they also come with potential risks, such as data security and privacy concerns and the need for continuous learning and adaptation to keep up with technological advancements.

Looking ahead, the future of architectural practice holds great promise with the integration of advanced digital tools such as parametric design, 3D modelling, simulation tools and AR. These technologies can revolutionise architectural design, creating a more sustainable and technologically advanced future. They can lead to the development of greener, more resilient urban spaces and foster collaborative and integrated design projects on a global scale.

## ACKNOWLEDGMENTS

A preliminary version of this paper was presented at the 2024 International Conference on Architecture, Technology, and Innovation (ATI), held on October 3-4, 2024, in Izmir, Turkey.

## REFERENCES

Abo-Elnor, M., Hamilton, R., & Boyle, J. (2004). Simulation of soil-blade interaction for sandy soil using advanced 3D finite element analysis. *Soil and Tillage Research*, 75(1), 61–73.

Agerwala, T., & Chatterjee, S. (2005). Computer architecture: Challenges and opportunities for the next decade. *IEEE Micro*, 25(3), 58-69.

Bijl, J. L., & Boer, C. A. (2011). *Advanced 3D visualisation for simulation using game technology*. Paper presented at the Proceedings of the 2011 Winter Simulation Conference (WSC).

Broschart, D., & Zeile, P. (2015). Architecture: Augmented reality in architecture and urban planning. *Peer-reviewed proceedings of digital landscape architecture*, 2015, 111.

Chi, H.-L., Kang, S.-C., & Wang, X. (2013). Research trends and opportunities of augmented reality applications in architecture, engineering, and construction. *Automation in Construction*, 33, 116-122.

Chokhachian, A. (2014). *Studies on architecture design procedure: A framework for parametric design thinking*. Eastern Mediterranean University (EMU)-Doğu Akdeniz Üniversitesi (DAÜ).

Dow, S. P. (2008). Understanding user engagement in immersive and interactive stories: Georgia Institute of Technology.

Eltaweel, A., & Yuehong, S. (2017). Parametric design and daylighting: A literature review. *Renewable and Sustainable Energy Reviews*, 73, 1086-1103.

Gaggioli, A. (2016). Transformative experience design. Human-computer confluence. We are transforming the human experience through symbiotic technologies, pp. 96–121.

Ghazal, I., Mansour, R., & Davidová, M. (2023). AGRI | gen: analysis and design of a parametric modular system for vertical urban agriculture. *Sustainability*, 15(6), 5284.

Gu, N., Yu, R., & Behbahani, P. A. (2021). Parametric design: Theoretical development and algorithmic foundation for design generation in architecture. *Handbook of the Mathematics of the Arts and Sciences*, 1361–1383.

Hajirasouli, A., Banihashemi, S., Drogemuller, R., Fazeli, A., & Mohandas, S. R. (2022). Augmented reality in design and construction: Thematic analysis and conceptual frameworks. *Construction Innovation*, 22(3), 412–443.

Han, Y., Zhang, K., Xu, Y., Wang, H., & Chai, T. (2023). Application of parametric design in the optimisation of traditional landscape architecture. *Processes*, 11(2), 639

Horelli, L., & Wallin, S. (2013). Towards an architecture of opportunities. *New Approaches to Urban Planning-Insights from Participatory*

*Communities*, pp. 153–161.

Hudson, R. (2008). *Frameworks for practical parametric design in architecture*. Paper presented at the Proceedings of the 26th eCAADe Conference.

Hudson, R. (2010). Strategies for parametric design in architecture. *Civ. Eng.*, pp. 274, 77–81.

Jessen, A., Hilken, T., Chylinski, M., Mahr, D., Heller, J., Keeling, D. I., & de Ruyter, K. (2020). The playground effect: How augmented reality drives creative customer engagement. *Journal of Business Research*, 116, 85-98.

Kensek, K., Noble, D., Schiller, M., & Tripathi, A. (2000). Augmented reality: An application for architecture *Computing in Civil and Building Engineering* (2000) (pp. 294–301).

Khan, H. (2024). Microclimatic architectural design by interfacing grasshoppers and Dynamo with Rhino and Revit. *Measurement: Sensors*, p. 33, 101143.

Liu, P. L., Yeh, H. H., & Synolakis, C. (2008). *Advanced numerical models for simulating tsunami waves and runup* (Vol. 10): World Scientific.

Mackintosh, L. (2018). *Sustaining Learning: Transformative Experiences in Architectural Education: PhD Architecture*. The University of Western Australia.

Maksoud, A., Hussien, A., Mushtaha, E., & Alawneh, S. I. A. R. (2023). Computational Design and Virtual Reality Tools as an Effective Approach for Designing Optimization, Enhancement, and Validation of Islamic Parametric Elevation. *Buildings*, 13(5), 1204.

Mohorko, J., Matjaz, F., & Sasa, K. (2008). Advanced modelling and simulation methods for communication networks. *Microwave Review*, 14, 41-46.

Monedero, J. (2000). Parametric design: a review and some experiences. *Automation in Construction*, 9(4), 369–377.

Na, S. (2021). Case analysis and applicability review of parametric design in landscape architectural design. *Journal of the Korean Institute of Landscape Architecture*, 49(2), 1–16.

Naboni, R., & Paoletti, I. (2015). *Advanced customisation in architectural design and construction*: Springer.

Pallasena, R. K., Sharma, M., & Krishnaswamy, V. (2022). A Study of Interaction, Visual Canvas, and Immersion in AR Design: A DSR Approach. *AIS Transactions on Human-Computer Interaction*, 14(3), 390–425.

Pey, K. L., Blessing, L., & Tuncer, B. (2020). *A transformative engineering and architecture education*. Paper presented at the 2020 IEEE Frontiers in Education Conference (FIE).

Rohani, M., Fan, M., & Yu, C. (2014). Advanced visualisation and simulation techniques for modern construction management. *Indoor and Built Environment*,

23(5), 665-674.

Romaniak, K., & Filipowski, S. (2018). Parametric design in the education of architecture students. *World Transactions on Engineering and Technology Education*, 16(4), 386-391.

Sabin, J. (2015). Transformative research practice: Architectural affordances and crisis. *Journal of Architectural Education*, 69(1), 63–71.

Salama, A. M. (2021). *Transformative pedagogy in architecture and urbanism*: Routledge.

Scholz, J., & Smith, A. N. (2016). Augmented reality: Designing immersive experiences that maximise consumer engagement. *Business Horizons*, 59(2), 149-161.

Schumacher, P. (2015). Design parameters to parametric design *The Routledge Companion for Architecture Design and Practice* (pp. 3-20): Routledge.

Shen, X., Padua, M. G., & Kirkwood, N. G. (2024). Transformative Impact of Technology in Landscape Architecture on Landscape Research: Trends, Concepts and Roles. *Land*, 13(5), 630.

Song, Y., Koeck, R., & Luo, S. (2021). Review and analysis of augmented reality (AR) literature for digital architectural fabrication. *Automation in Construction*, 128, 103762.

Tuzun Canadinc, S., & Yan, W. (2022, January). 3D-Model-Based Augmented Reality for Enhancing Physical Architectural Models. In *Proceedings of the 40th Conference on Education and Research in Computer Aided Architectural Design in Europe* (eCAADe, 2022) (Vol. 2).

Vajta, L., & Juhasz, T. (2005). The Role of 3D Simulation in the Advanced Robotic Design, Test and Control *Cutting Edge Robotics* (pp. 47-60): IntechOpen.

URL 1: <https://www.archdaily.com/229454/in-progress-shanghai-tower-gensler>

URL 2: <https://www.archdaily.com/448774/heydar-aliyev-center-zaha-hadid-architects>

URL 3: <https://www.archdaily.com/270592/al-bahar-towers-responsive-facade-aedas>

URL 4: <https://www.archdaily.com/896433/morpheus-hotel-zaha-hadid-architects>

Wortmann, T., & Tunçer, B. (2017). Differentiating parametric design: Digital workflows in contemporary architecture and construction. *Design Studies*, 52, 173-197.

Yu, R., Gu, N., Lee, G., & Khan, A. (2022). A systematic review of architectural design collaboration in immersive virtual environments. *Designs*, 6(5), 93.



# **RADICAL PEDAGOGIES AND EDUCATION**



# Eco-sensitive Cyberatmospheres

Ecocentric transformations of domestic spaces

artes interactivas  
visuales  
programación  
ecología sensorial  
comunicación paramétrica  
**interactive arts**  
**visuals**  
**programming**  
**sensory ecology**  
**parametric communication**

Este trabajo pretende abrir un debate sobre el enfoque actual de la tecnología en el espacio doméstico. En la actualidad, está considerado como un avance uso de la tecnología como un método para simplificar nuestras acciones humanas y no como una posibilidad de su extensión sensorial hacia el medio que nos rodea. Por otro lado, el trabajo también se utiliza como parte experimental en la que, a través del testeo del software "touch designer" se replantea el enfoque tecnológico en los espacios domésticos hacia una tecnología más comunicativa que resolutive. El discurso planteado es el cambio del enfoque antropocentrista de lo doméstico en un ecocentrismo sensible, sustituyendo así el sujeto humano por el medio comunicador (se entiende como medio comunicador todo agente no-humano, climatológico, animal, vegetal, etc.). De esta manera se establece un intercambio de información visual, a través de lo tecnológico, representando comportamientos y necesidades.

This work aims to open up a debate on the current approach to technology in domestic spaces. Currently, the use of technology is seen as a way to simplify human actions, rather than as a possibility for extending our sensory connection to the surrounding environment. It is also used experimentally, where, through testing the "TouchDesigner" software, the technological approach in domestic spaces is rethought towards a more communicative than solution-oriented technology. The proposed discourse is a shift from the anthropocentric approach of the domestic space to a sensitive ecocentrism, where the human subject is replaced by the communicative environment (understood as any non-human agent, climatic, animal, plant, etc.). In this way, a visual exchange of information is established through technology, representing behaviours and needs.

**Manchón Martínez, Lucía<sup>1</sup>**

<sup>1</sup> Architect, Master's in Architecture, Alicante University, Alicante, Spain.  
luciamanez32@gmail.com

Citation: Manchón Martínez, L. (2024). "Eco-sensitive Cyberatmospheres" UOU scientific journal #08, 158-165.

ISSN: 2697-1518. <https://doi.org/10.14198/UOU.2024.8.15>  
This document is under a Creative Commons Attribution 4.0 International license (CC BY 4.0)

Received: 14/09/2024  
Received in revised form: 02/10/2024  
Accepted: 24/11/2024





## INTRODUCTION

The main driving force behind this work is a personal interest in understanding how the concept of "inhabiting the future" is perceived today and generating a debate around its anthropocentric approach. The goal is not to radicalise or impose a specific viewpoint, but to question the values and priorities of society in regards to the occupation of space and how it can respond.

## METHODOLOGY

The proposal is to transform the home into a space that meets the sensory needs of the inhabitant, inspired by digital systems used in art, such as exhibitions, concerts, or festivals. The goal is to rethink the priorities of home automation, giving prominence to "secondary agents" inside and outside the home that influence the domestic environment.

The idea is to create a dynamic and adaptable space where basic human needs are not the main focus. Using tools like TouchDesigner, the other agents in the environment will modify the space to communicate with the inhabitant through sensations.

## THE ANTHROPOCENTRIC APPROACH TO SMART HOMES: The Domestic Coldness of the Future

Technological advancements not only create digital worlds but also offer practical solutions to the real world. One example is home automation, defined by the RAE (Real Academia Española) as "systems that automate the installations of a home."<sup>2</sup> This concept of the *smart home*

(Fig.1) connects and gives "life" to household elements, from appliances to walls, allowing people to control them remotely and have greater control over domestic activities.

Today, we can experience what it would be like to live in a smart home thanks to devices and applications that enhance comfort (Fig.2). However, home automation remains anthropocentric. Do we really need machines for tasks we could do ourselves? Does it make us more efficient, or does it only eliminate simple tasks, thus increasing our dependence on machines and reducing our autonomy?

Moreover, it is crucial to reflect on its emotional impact. Why do we prioritise physical comfort over mental well-being? Could technology focus on improving our emotional quality of life as the foundation for a more balanced life?

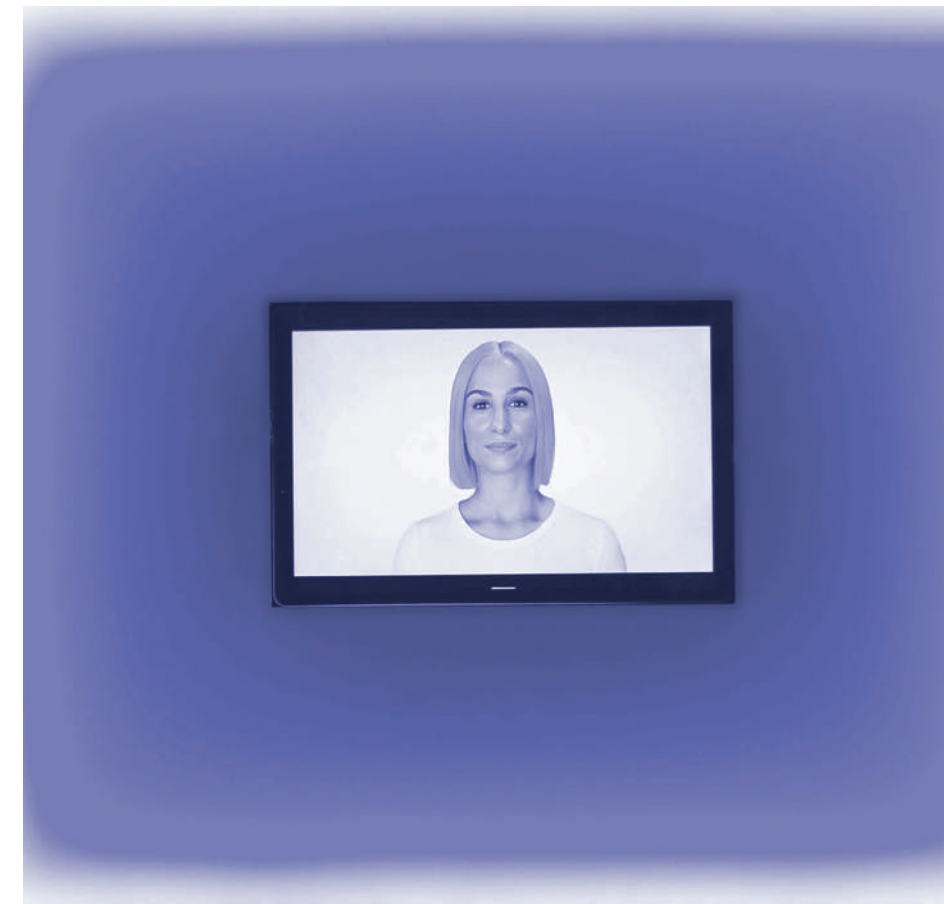

Fig.2 - Cyberhut's virtual assistant that handles all the tasks for us. Available at < <https://www.cyberhut.io/vivienda> >).

## A STARTING POINT TOWARD WARM DOMESTICITY: From Anthropocentric Places to Sensitive Ecocentric Spaces

We must move away from the idea of a human-centered world and adopt a more ecocentric mindset, without forgetting our connection to the ecosystem. Architect María Auxiliadora Gálvez proposes seeing humans as bodies "in ecodependence with the environment"<sup>3</sup> that is, as "animated structures"<sup>4</sup> interacting with the surroundings (Fig.3).

Her approach incorporates concepts like sensory psychology, sensory ecology and somatic ethnography, suggesting that all beings must cooperate and relate synergistically. While traditional ecology studies the exchange of materials and energy between organisms, sensory ecology focuses

on the influences that affect behaviors and functions.

Gálvez also emphasizes the importance of reflecting on our view of the world and ourselves. Changing how we perceive ourselves and our relationship with other beings is key to transforming our actions and the design of our environment.

## CYBERATMOPHERES

In this section, a series of real-time informational visual projections are presented, based on the theoretical discourse and the knowledge gained through experiments with TouchDesigner, a visual programming software capable of generating interactive content through real-time information analysis. The aim is to illustrate the shift in technological application within the domestic sphere. Cyber-atmospheres break all cyberspatial and anthropocentric barriers, enabling dialogue and sensory experimentation between agents.



Fig.1 - Interior of the "Cyberhut" house, a home designed with a virtual assistant that autonomously manages the property to provide a more comfortable and optimized living experience. Available at < <https://www.cyberhut.io/vivienda> >).

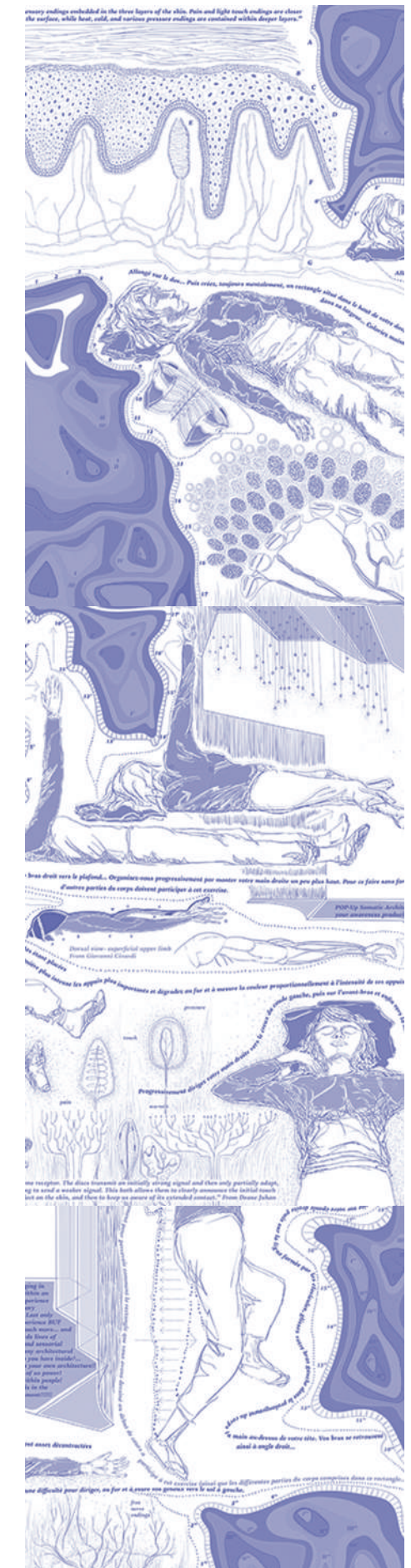

Fig.3 - Explanatory images that María Auxiliadora uses to strengthen her work. < <https://psaap.com/pop-up-somatic-architecture/> >).



## CYBERATMOSPHERE 1

*I woke up, like as every morning, while listening to a sound I still couldn't quite distinguish clearly. The particles on the floor told me that something was happening in my house. I approached the living room balcony and saw the sparrows that lived in the tree across the street occupying the table where I am used to having coffee every afternoon. The particles stopped glowing. My presence had frightened them away, leaving the house without their songs.*

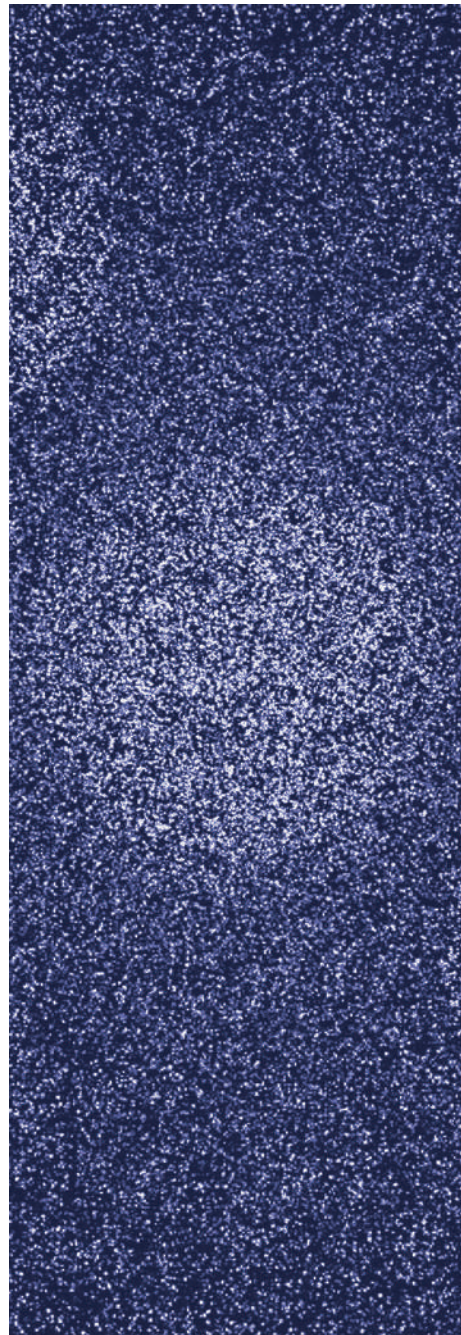

Fig.4 - Visual generated by TouchDesigner of the Cyberatmosphere 1.

### TECHNICAL SPECIFICATION

- COMMUNICATIVE AGENT. Birdsong.
- VISUAL DESCRIPTION. Particles on which circular shapes appear (Fig.4), highlighting them in response to the external sound provided by the presence of animal agents.
- RESPONSE OF THE RECEIVER AGENT. Communicative visual. While the person is in the room (Fig.5), she/he is aware that there is an animal presence in an external space within their domestic



Fig.5 -Explanatory axonometry of the visual functioning for Cyberatmosphere 1.

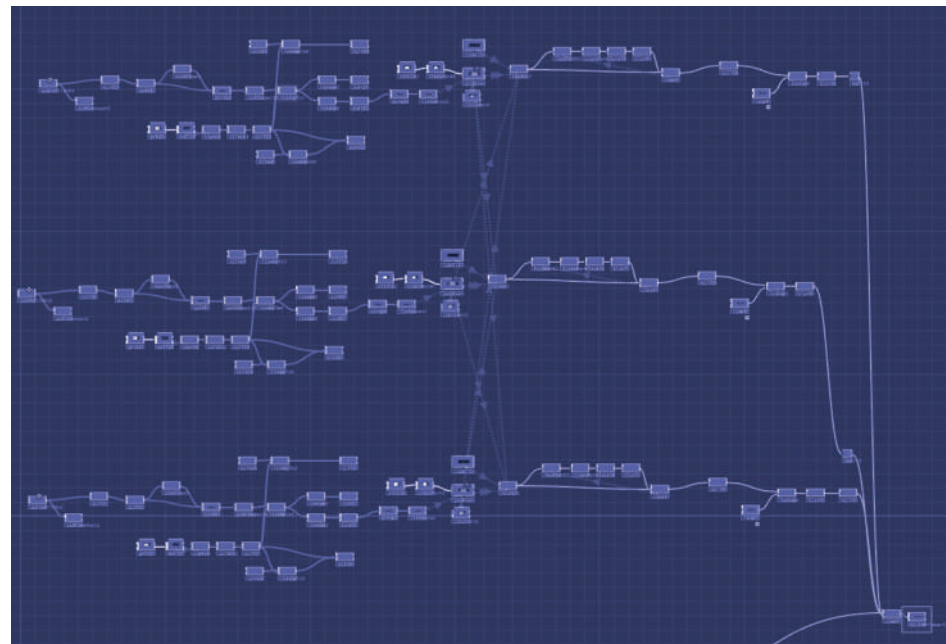

Fig.6 - Visual programming in TouchDesigner to create and operate the visuals for Cyberatmosphere 1.

environment.

- FUNCTIONAL TECHNICAL APPROACH. From microphones located on the external surfaces, the intensity and rhythm of the sound are analysed. Once captured, it will be processed through TouchDesigner (Fig.6), where the numerical value extracted from the audio will be associated with the diameter value. In this way, depending on the sound captured by each microphone, the distance of the animal and the vocalisation, a series of larger or smaller circular shapes will appear.

## CYBERATMOSPHERE 2

*After a whole morning of hiking in the mountains, I wanted nothing more than a nice hot bath and to relax. I entered the bathroom and undressed when suddenly I started to feel the warm water cascading over my shoulders and back. I opened my eyes and saw the lines that had previously been completely defined on the wall now blurred. By the time I realised it, an hour had passed and the bathroom had turned into a sauna.*

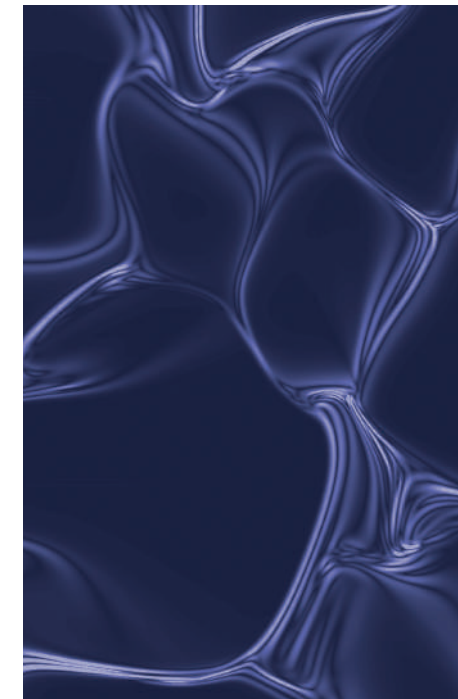

Fig.7 - Visual generated by TouchDesigner of the Cyberatmosphere 2.

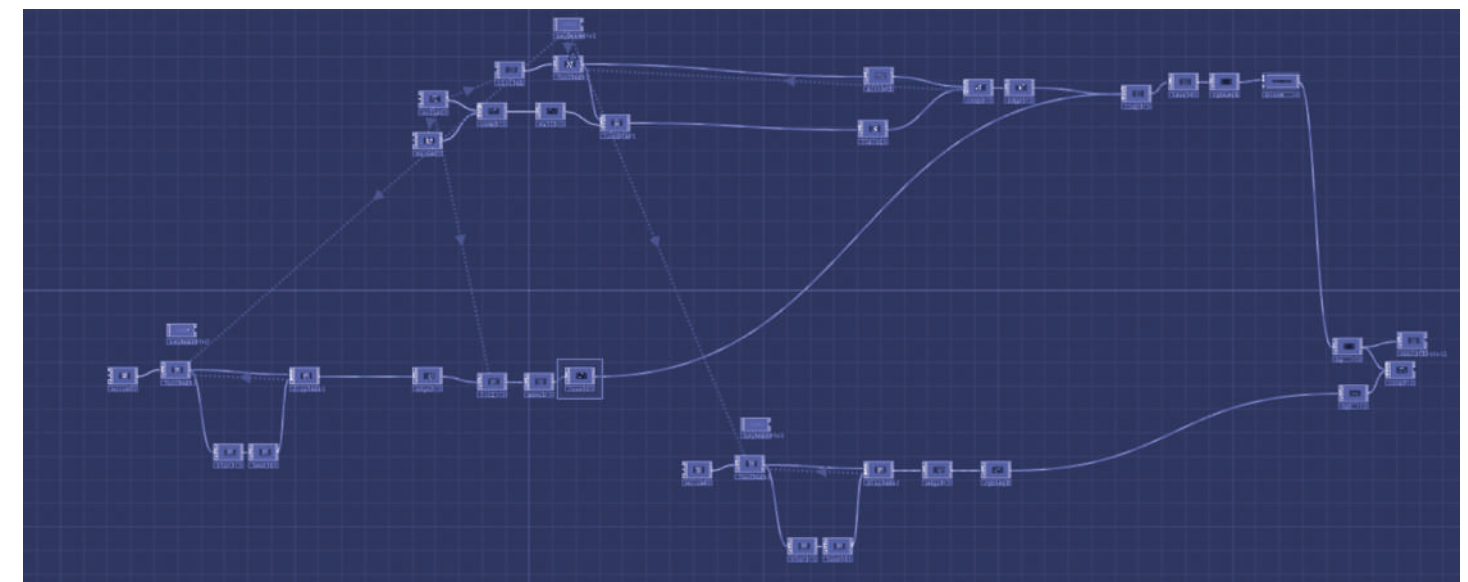

Fig.9 - Visual programming in TouchDesigner to create and operate the visuals for Cyberatmosphere 2.

### TECHNICAL SPECIFICATION

- COMMUNICATIVE AGENT. Humidity and temperature.
- VISUAL DESCRIPTION. Representation of a water projection (Fig.7) as a line when the temperature and humidity in the room are at normal levels, blurring into dots as these values increase.
- RESPONSE OF THE RECEIVER AGENT. Communicative visual. While the person is showering (Fig.8), these visuals indicate that the conditions in the bathroom are

changing due to the use being made of it.

- FUNCTIONAL TECHNICAL APPROACH. Using a hygrometer and a thermometer, the humidity and temperature of the room are analysed. Once captured, this data will be processed through TouchDesigner (Fig.9), where the numerical value extracted from the environment will be assigned to a specific projection. In this way, depending on the atmospheric conditions in the bathroom over time, a more defined or diffuse image will be projected.

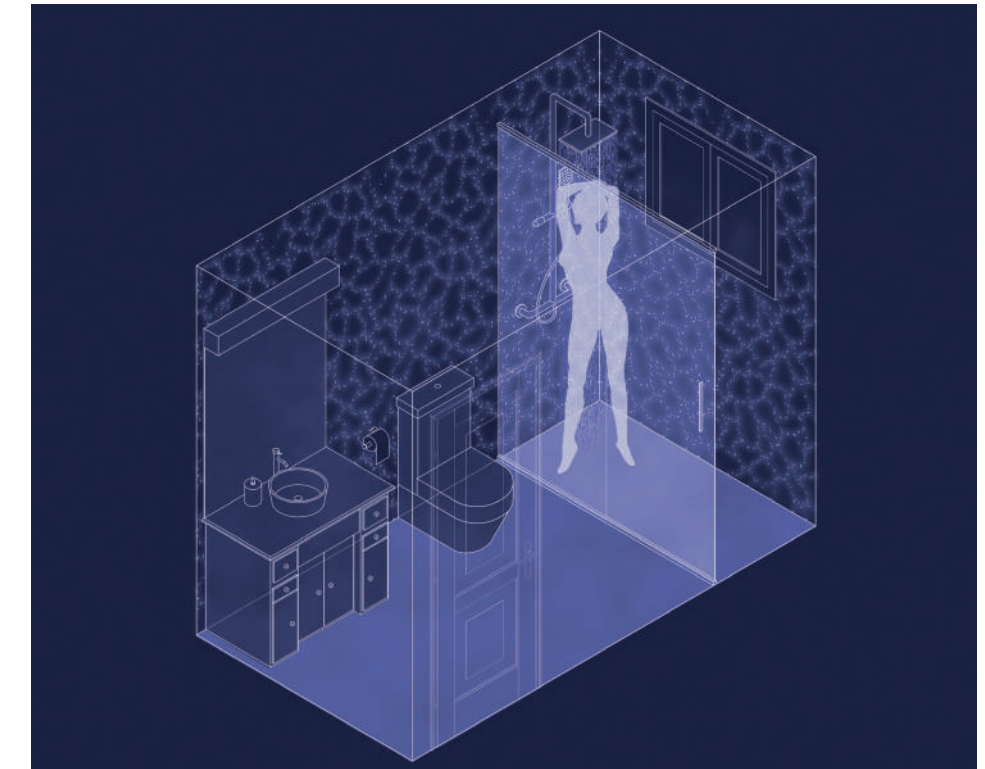

Fig.8 - Explanatory axonometry of the visual functioning for Cyberatmosphere 2.



## CYBERATMOSPHERE 3

*It was a very sunny Saturday and it was quite hot. I had the whole day free, so I decided to take a rest and sit on the sofa to watch TV. I noticed a change in the room. The plant drawings that filled the space looked sad and wilted. I decided to grab the watering can, fill it with water and go tend to the plants on my balcony. When I returned, the vegetation was happy again.*

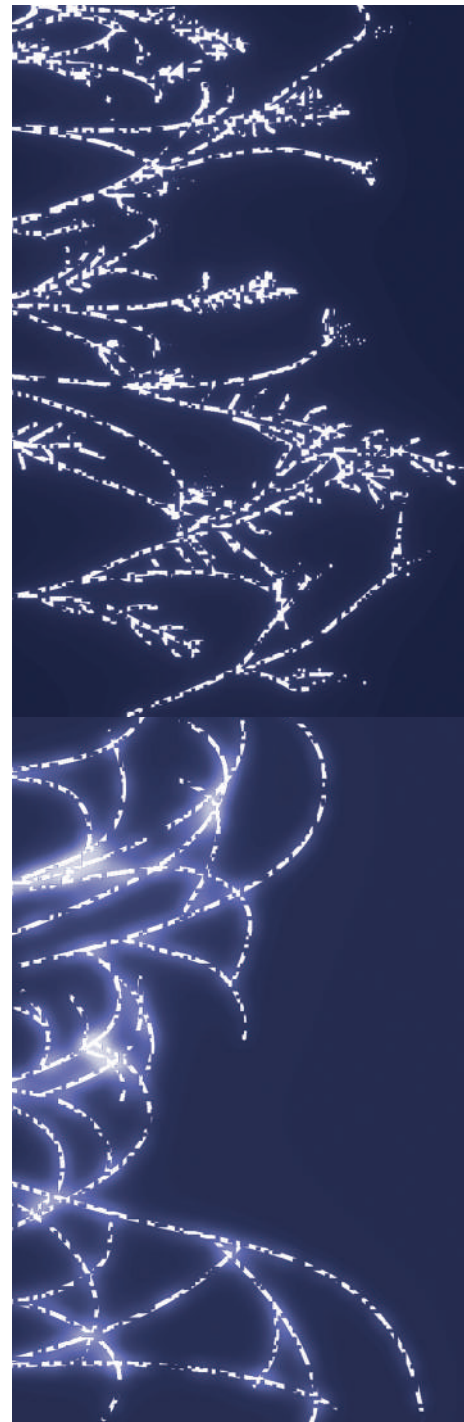

Fig.10 - Visual generated by TouchDesigner of the Cyberatmosphere 3.

### TECHNICAL SPECIFICATION

- COMMUNICATIVE AGENT. The vegetation through the soil moisture parameters.

- VISUAL DESCRIPTION. Plants are happy when the moisture level is optimal, wilting when this value falls below the necessary level (Fig.10).

- RESPONSE OF THE RECEIVER AGENT. Provide the necessary amount of water (Fig.11) so that the soil moisture percentage returns to optimal values.

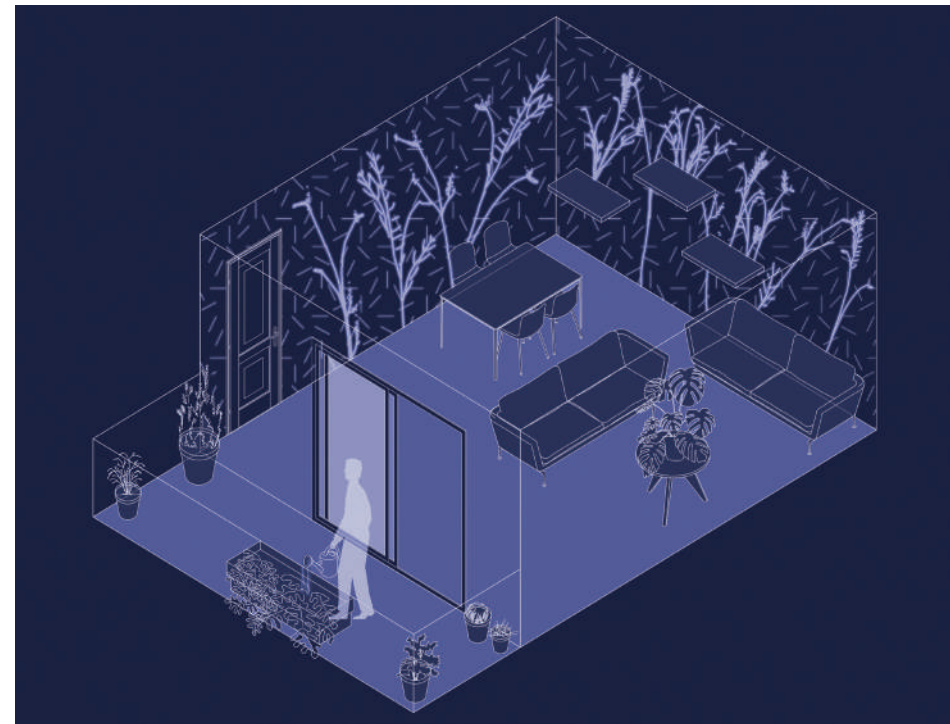

Fig.11 - Explanatory axonometry of the visual functioning for Cyberatmosphere 3.

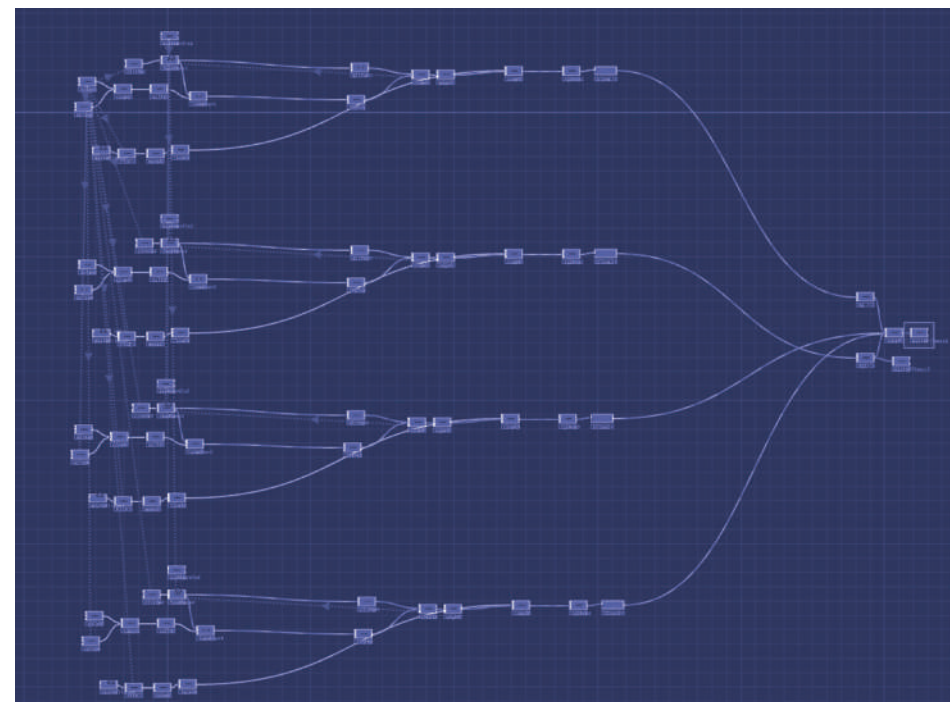

Fig.12 - Visual programming in TouchDesigner to create and operate the visuals for Cyberatmosphere 3.

- FUNCTIONAL TECHNICAL APPROACH. Using a moisture meter placed in the planter, the percentage is analysed through values. These values will be classified into different levels of optimal and insufficient. Once classified, each level will be associated in TouchDesigner (Fig.12) with a visual representation of the plant's condition. In this way, depending on the soil moisture, the vegetation's needs will be visualised.

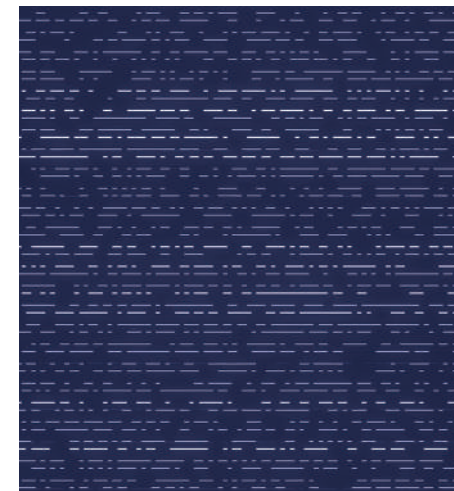

Fig.13 - Visual generated by TouchDesigner of the Cyberatmosphere 4.

## CYBERATMOSPHERE 4

*I had just got up when I decided to go to the kitchen for breakfast. There was my sister, sweaty from having got up early to go running. The lines in the kitchen were very spread out and dynamic. While I was having breakfast, she was eating an apple and a piece of chocolate. The wall started to become saturated with these strokes. My sister, without passing her phone over the patch, went to the fridge to inject her own insulin after any meal. The wall stopped being saturated.*

### TECHNICAL SPECIFICATION

- COMMUNICATIVE AGENT. Blood through a smart patch that monitors glucose levels.

- VISUAL DESCRIPTION. A series of short, dynamic vertical lines are represented (Fig.13), which get closer together and lengthen even more when blood glucose levels rise above recommended values.

- RESPONSE OF THE RECEIVER AGENT. Reduce the sugar level through physical actions, pills or insulin injections (Fig.14).

- FUNCTIONAL TECHNICAL APPROACH. Using a smart patch, the blood glucose level is analysed. Once captured, this data will be processed through TouchDesigner (Fig.15), where the numerical value extracted from the patch will be assigned to the number of points from which a line will start to be created. In this way, the higher

the value, the more lines will be visualised, creating a saturation in the projection.

### CONCLUSION

Implementing technology from this new perspective completely changes the experience of the human inhabitant in the domestic space, shifting from feeling like the primary owner of everything and the one who must be served, to simply being another co-inhabitant of the environment. In this way, a closer relationship is established, one that is more conscious of the fact that we are not alone on this planet, but that many other beings coexist with us.

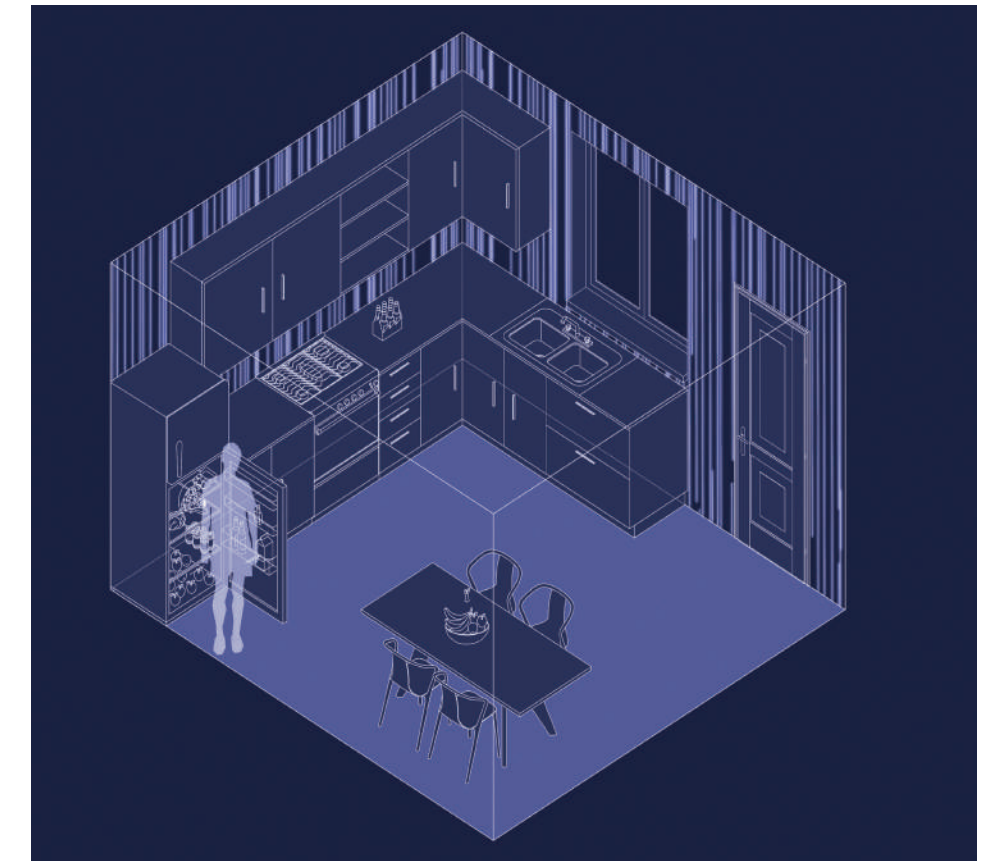

Fig.14 - Explanatory axonometry of the visual functioning for Cyberatmosphere 4.

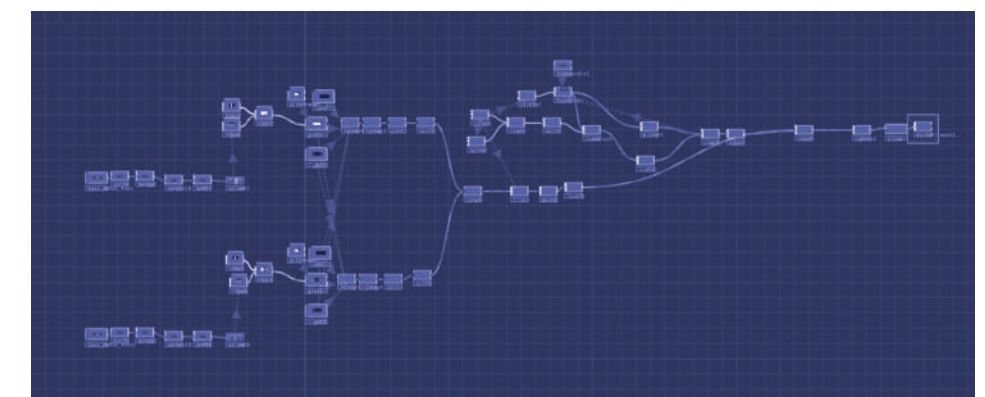

Fig.15 - Visual programming in TouchDesigner to create and operate the visuals for Cyberatmosphere 4.

## NOTES AND REFERENCES

1. This concept is used to refer to everything involved in our environment: temperature, animals, plants, cells, and more.

2. Real Academia Española. Domótico, domótica. Diccionario de la lengua española. [online]. Update 2023. Madrid: Real Academia Española. Available at: <https://dle.rae.es/dom%C3%B3tico> [Accessed: 5 December 2024].

3. Humans need nature because we are inherently connected to its conditions.

4. Arquitectura somática. YouTube. [online video]. Published by arquitectura Unicosta, 7 September 2020. Available at: <https://www.youtube.com/watch?v=xfm5qc86NIQ> [Accessed: 5 December 2024].



# ATLAS



# Radical Atlas

**The UNIVERSITY of Universities (UOU) is a truly remarkable collective effort to create an international network of academics from European schools of architecture collaborating to provide online workshops along the academic year for students from different universities who work together remotely and in a collaborative way.**

**This Radical Atlas section shows the work that undergraduate students have conducted in a three weeks workshop a solid research to design a Radical proposal (as in the call of this issue# 8 Radical Futures) as the central theme. This collective platform enhances cultural diversity and nexus of unity among participating students.**

**Besides (or parallel) to the workshop the journal received important contributions from artists and students around the world and these will be included in the final section of this ATLAS:**

**Artistic works:** Emanuele Quinz (Full professor, Université Paris 8), Marco Pace (artist and professor).

**Student works:** Mads Hvidkær Christoffersen (Umeå School of Architecture) and George Azer (Università Mediterranea di Reggio Calabria)

The workshop had two different (and main) physical locations. The first one rooted within a Design Studio Course at the Alicante School of Architecture (the core of UOU, so to speak) and a second unit at Universidad Europea de Madrid, where students of Communication Skills + students from Architecture and Art of the 20 and 21 century joined this European teaching project.

The total number of students that participated in this workshop is around 100, and this Atlas is a selection of what we believe a student's radical approach to the topic. The selected ones are:

#### Universidad Europea de Madrid:

- **Team 01:** Jakob Schreiner Benito, Nina Méndez Bisgaard, Micheline Bood.
- **Team 02:** Valentina Andrade, Valentina Scampini, Elisa Merchán.
- **Proposal 03:** Juan Pablo Díaz Hernández.
- **Team 04:** Adam Ihab, Celeste Ortiz, Camila Gómez, Fernando Salinas, Mariapaula Vigo.
- **Team 05:** Andrei Constantinescu, Kenza Nakhli, Javier Prados, Rania Melehi Loudiyi.
- **Team 06:** Ciro Ramírez, Racse Ramos, Sophia Obando, Raquel Vidales, Helen González, Silvana Torin.

#### Universidad de Alicante:

- **Team 07:** Lucía Callatopa, Mara Van Vliet, Zoia Dolgova, Aneta Báčová, Lucia Strýčková, Selina Untermaier.
- **Team 08:** Esther Oliver Marín, Gadea Vicente Caravaca.
- **Team 09:** Noah Pashkevich, Max Darwall, Leonhard Sigmund, Nina Lütcke.

#### Faculty of Architecture. Budapest University:

- **Team 10:** Yasmine El Bada, Franz Schubert, Aron Schönfeld.

By lecturing on Radical Architecture we believe that a completely different tool is provided to our students, because if what we do (at least traditionally) is about the "Art of building", with this radical mindset the students relate to architecture as a way to criticize the world. Full of things to criticize... by the way.

Overconsumption, overpopulation, capitalism, climate change and some other contemporary issues are part of this Atlas. But let me please remind you that this projects DO NOT solve this problems... this projects UNDERSCORE this issues so they raise awareness.

I hope you enjoy them!

## CONTENT

Radical Architecture is, according to Maigayrou, a "current of research less concerned with the practice of the architectural profession than with reflecting on the bases, the foundations of architecture" and we can identify it (in the current dizzying world of instant consumption of images) with projects such as the Pneumacosmos (Haus Rucker Co, 1967), the Continuous Monument (Superstudio, 1969) or the No Stop City (Archizoom, 1970).

This workshop is intended to confront the world we have received by making its paradoxes visible and revealing the absurdity of a discipline that continues to insist on defining itself from formal and stylistic aspects to deviate towards a factual, operational architecture that acts on the real... even if it does not build anything (especially not building anything).

In this course we will deal with:

- The purpose of architecture
- Unbuildable buildings
- Utopia and dystopia
- Temporary radical proposals
- Radical and scale-less urbanism

## AIMS

Take on a path around the following public interests:

- Detect present social issues and conflicts by linking architecture and criticism acknowledging how the different layers are built up.
- Build confidence in working with unknown students/partners from abroad and establish multidisciplinary relationships.
- Furthermore, this exercise provides two focal points: It is a reflection and meets the need of thinking and designing. The student is asked to go back to the original Radical Architecture period and reflect in a critical manner where his/her proposal offers/adds to the original movement. The submission can therefore be edited if needed, considering the feedback from the CRITS.
- Additionally, the student is asked

to think as a Radical Architect. This means to follow a very specific mindset where architecture is not "the art of building" but the need to critically address the world and to reflect on it using architectural tools.

## METHOD

1. Research and reflect about architecture as a radical discipline.
2. Select your topic and scale (from the XS of furniture to the XL of planetary urbanism), locate it in our (or other) planet and briefly present it to the rest of the students (in groups of 3-4).
3. Compose a genealogy or bloodline of radical projects that anticipated yours.
4. Write down a sequence of words to summarize your radical project (such as indiscipline, fear, game, utopia...etc)
5. Design an action/activity, according to your radical proposal prior to the design of anything and present it to the rest of the students.
6. Achieve and draw design, architecture or urbanism that fits the previous radical action/activity.

By implementing this working method, the student will go beyond a formalistic approach and will deliver a more radical proposal.

The final exercise is to create a Drawing where the students are asked to put together their radical present proposal + a short Manifesto to reflect on the result. The content of this final submission should summarize the working process during the workshop as follows:

0. The concept and genealogy of Radical Architecture.
1. The initial intuition and presentation (with images) of each proposal.
2. The bloodline creation to better explain their goals.
3. Putting together the words that would explain it if no images were allowed.
4. The design of the action that probed your radical approach. Each student must show clearly his/her contribution to the proposal. Therefore, individual documents

and collective documents should be included separately.

5. The technical drawing - A DETAIL, A FLOOR PLAN, AN ELEVATION...etc - of the RADICAL PRESENT in the specific location that it's intended to criticize.

6. Finally, include a Manifesto on the Radical proposal.

7. Bibliography.

## EVALUATION

It is continuous, grading the workshop submissions every week, carried out by the professors as well as fellow students:

- Skills of analysing and deconstructing Radical Architecture.
- Identification of present social issues and cultural conflicts.
- Ability to draw that concept through an action/event within the radical proposal.

## SCHEDULE

- RADICAL PRESENT Workshop Presentation online / 25th October 2024
- Classes online UOU / Fridays from 9:30 to 13:30 (CET): 8th November 2024 and 15th November 2024
- RADICAL PRESENT FESTIVAL Face-to-face in Alicante / 22nd November 2024

## BIBLIOGRAPHY

- Archizoom. No-Stop-City. Milán: Domus; 1971
- Branzi, A. Una generazione esagerata. Dai radical italiani alla crisi della globalizzazione. Milán: Baldini&Castoldi; 2014
- Colomina, B, Buckley, C. Climp Stamp Fold. The radical architecture of Little magazines 196x to 197x. Barcelona: Actar; 2010
- Cook, P. Experimental architecture. Nueva York: Universe books; 1970
- Gargiani, R y Lampariello, B. Superstudio. Bari: Laterza; 2010
- Gargiani, R. Dall'onda pop alla superficie neutra. Archizoom associati 1966- 1974. Milano: Mondadori Electa; 2007
- Haus Rucker Co. Haus Rucker Co. Londres: Architectural Design; 1971b
- Jarauta, F. Arquitectura Radical. Las Palmas de Gran Canaria: La Imprenta; 2002.
- Koolhaas, R y Mau, B. SMLXL. Italia: Evergreen; 1995
- Luengo Angulo, Miguel. La Arquitectura Radical. Cinco puntos para una redescrición teórica. Buenos Aires: Diseño; 2020
- Navone, P y Orlandoni, B. Architettura "radicale". Segrate: Documenti di Casabella; 1974
- Pettena, G. Radicals. Architettura e design 1960/75. Firenze: Il Ventilabro; 1996
- Superstudio. The 12 ideal cities. Tokio: Toshi Jutaku Urban Housing; 1971

<sup>1</sup> Universidad Europea de Madrid, Escuela de Arquitectura, Ingeniería y Diseño, Madrid, Spain. <https://orcid.org/0000-0002-3758-0040> miguel.luengo@universidadeuropea.es

<sup>2</sup>AUD American University in Dubai, School of Architecture, Art and Design, Dubai, UAE. <https://orcid.org/0000-0003-1308-0874> jcarrillo@aud.edu

Citation: Luengo Angulo, M.; Carrillo Andrada, J.A. (2024). "Radical Atlas" UOU scientific journal #08, 168-191.





# The Air Loft

**Jakob Schreiner Benito<sup>1</sup>; Nina Méndez Bisgaard<sup>1</sup>;  
Micheline Bood<sup>1</sup>**

<sup>1</sup> Universidad Europea de Madrid, Spain

**In a post climate change world, the sea levels have risen to previously unimaginable heights. Take to the skies! The vast blue below, Mt. Everest's peak isolated from its body, the post-apocalyptic ice berg. With a scarcity of resources, mankind struggles to do what it does best. Survive.**

**Rays of sun and blue endlessness govern this world. Architecturally, the traditional house has had to make way for something different, something light. Aiming at the skies, the old house has had its roots cut. Freshwater-sucking, hovering flying machines have taken precedence, as the only architectural real estate worth investment is aerial.**

## Engineering

The Air Loft utilizes the shell of a zeppelin to house whoever is lucky enough to escape the liquid desert now dominating the world. The body of the ship, reaching 172 meters longitudinally, comes with an engine powering the four-blade propeller, giving thrust and mobility. Additionally, nine cylindrical wheels, 23 meters in diameter, give stability and structure.

Along the length of the ship a steel truss provides further steadfastness. The structure has had to make for a living unit, a set of staircases, a water harvesting system and five service levels. This has been solved by creating a further gap between the fourth and fifth wheel. The service levels

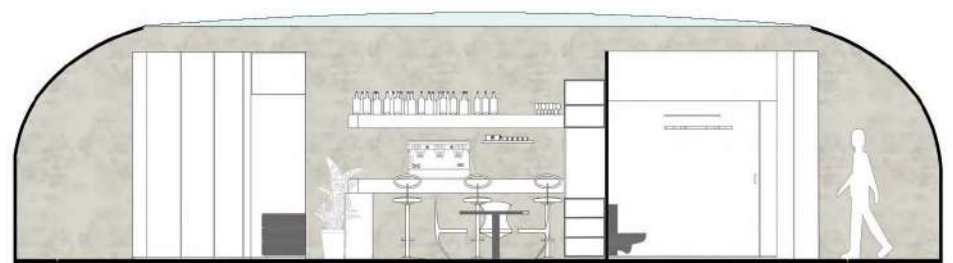

Bachelor Persona  
Plan 1:50

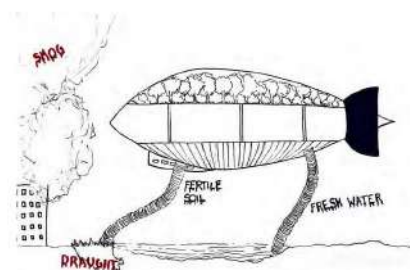
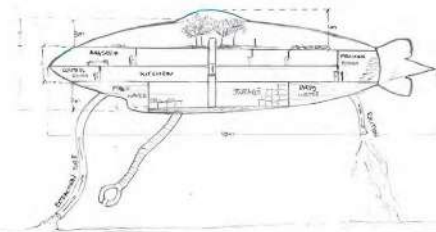
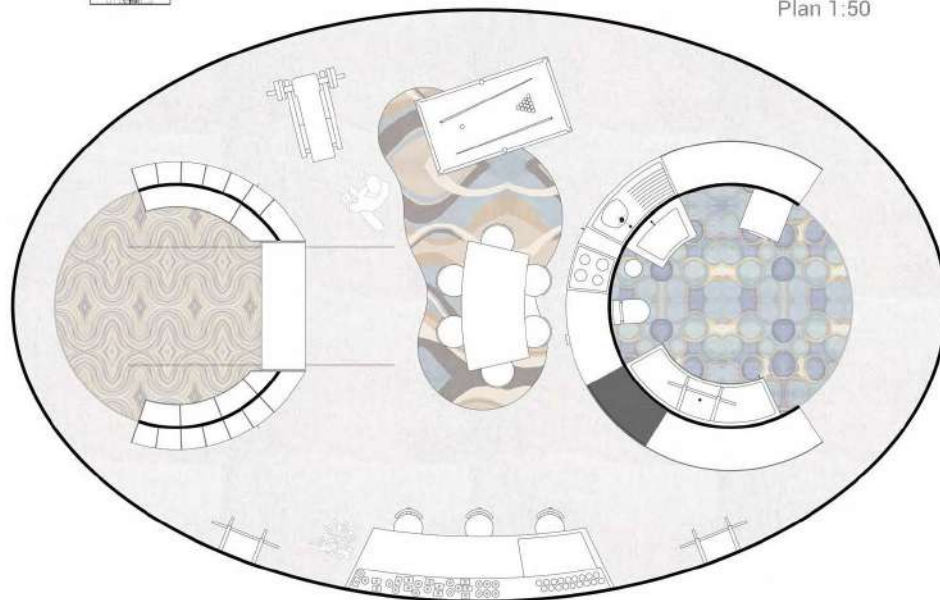

have been created by providing additional steel trusses working as slabs. The living unit rests on the top slab and initiates the staircase, which varies between traditional and ladder. The living unit also introduces the water harvesting pipe, which follows through the slabs until meeting the bottom steel truss, which further sends it to the exterior.

## Architecture

The living unit follows the morphology of the ship, giving it an oval shape. No expenses are spared! Although the architecture takes place in a post-apocalyptic world, this home provides high-tech solutions and adapts to various personality types.

Automatic mobile walls on each side of the unit contain the bedroom and bath spaces, but can rotate on command by the push of a button. This allows the spaces to become one, ideal for daytime activities. In other words, the space is dynamic and works with different needs throughout the day.

The whole unit is covered by an equally oval shaped skylight that provides light, but more importantly, functions as a weather forecast for the user. With decreased atmospheric pressure due to altitude, winds and wild weather are free to storm about, and vigilance on the skies becomes incredibly important. Apart from being technically flexible, the living unit comes in various outfits depending on the user. In order to illustrate examples, we've added three personality types along with their custom flying home.

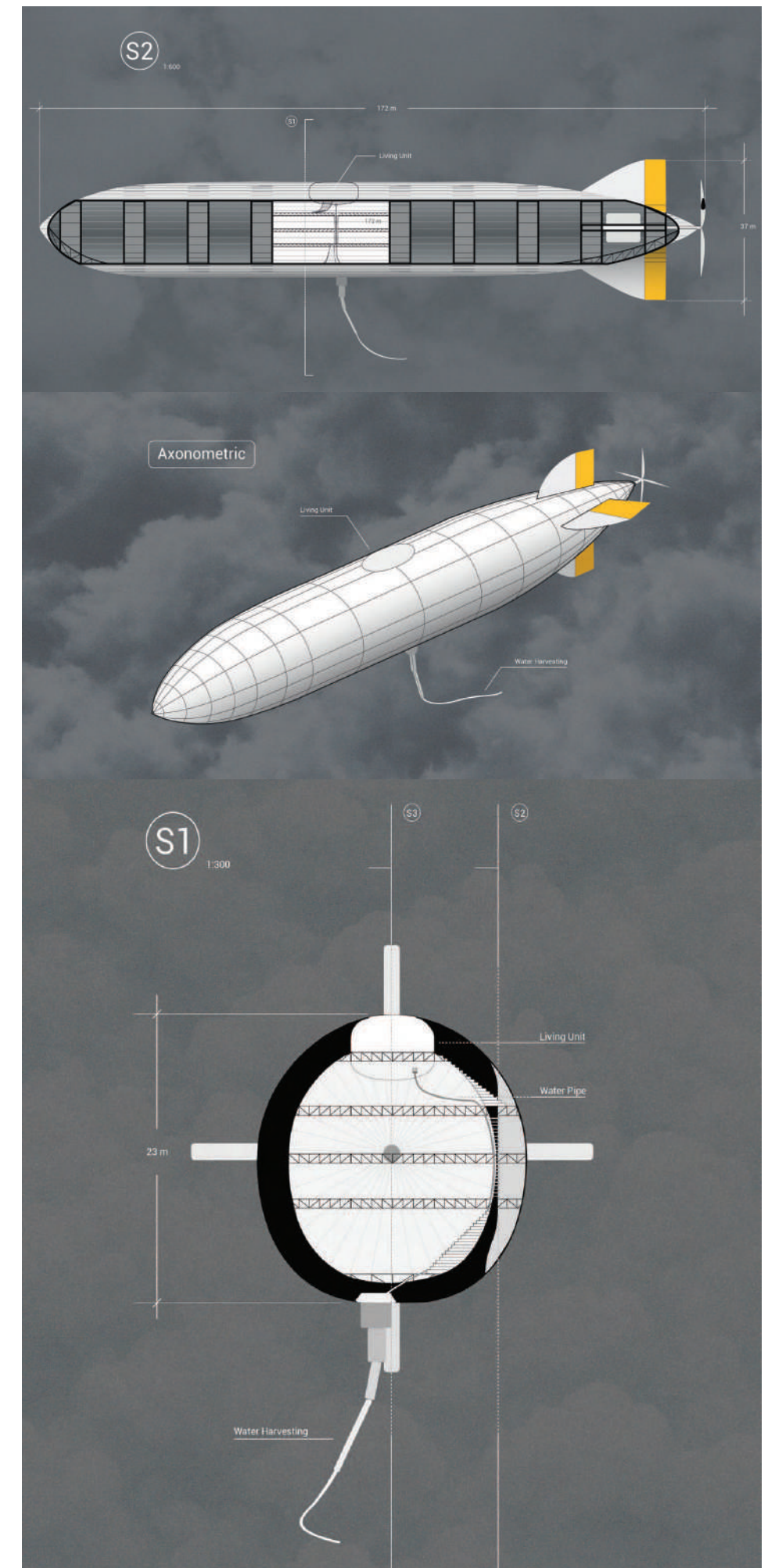



# Eden

## Valentina Andrade<sup>1</sup>; Valentina Scampini<sup>1</sup>; Elisa Merchan<sup>1</sup>

<sup>1</sup> Universidad Europea de Madrid, Spain

optimizes for comfort and lifestyle.

Eden is a self-sustaining environment, meticulously maintained and inhabited by men. It features state-of-the-art facilities tailored to enhance daily living, leisure, and productivity - redefining what it means to live the way a man truly should.

Discover a bold new frontier where functionality meets freedom. Welcome to Eden.

### ABOUT THE BUILDING:

This building features a sleek design with steel and glass, giving it a modern and luxurious look. Standing at 1320 meters tall, it towers over Los Angeles, making a bold statement.

The height - 1320 meters - was chosen to highlight a tragic statistic: every 10 days around 1320 women and girls worldwide are killed by an intimate partner or family member (UNODC). Each number represents a life lost, and this building serves as a reminder to honor their stories.

### 200 FLOORS

12,764,176 m<sup>2</sup> rendering it equivalent to:

- 11 El Retiro Parks
- 96 times the size of Madrid's Royal Palace
- 4 Central Parks, New York

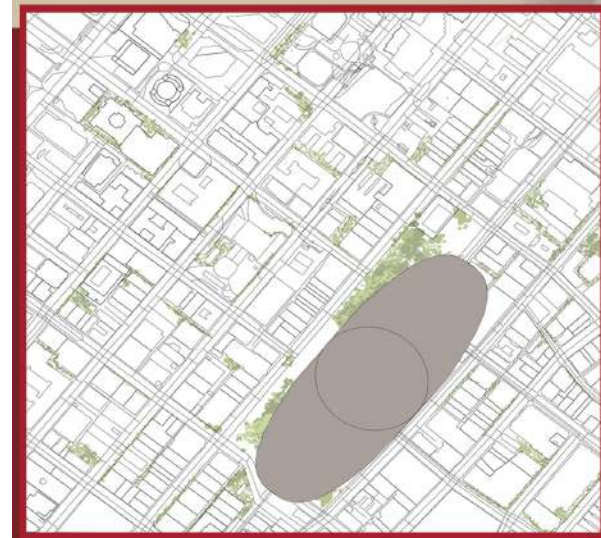

# E D E N

**SECTION A**  
AREA: 94,747 m<sup>2</sup>  
HEIGHT: 42 m

The ascent as a church represents how women's intellect and beliefs are often subjected to control and moral judgment under patriarchal systems. Historically, women's thoughts and actions have been policed, with institutions like religion dictating their roles and limiting their intellectual freedom. For instance, women make up 45-50% of church congregations worldwide, yet they are rarely allowed leadership roles, with only 15% of major religious organizations permitting female leaders (Pew Research, 2018). This metaphor also critiques the sanctification of 'purity' and abstinence, where women's minds are seen as spaces to be shaped and governed by societal norms, rather than independent places of exploration. Placing a church in the mind reflects the tension between personal identity and external control.

**FLOW DIAGRAM**  
The arrows are used to indicate the vertical communication.

**SECTION E**  
AREA: 1,807,331 m<sup>2</sup>  
HEIGHT: 108 m

The forest as a private or public and housing or offices the social role of women's bodies as spaces to be owned, controlled, and at times for others' benefit. Spaces associated with nurturing and care are often reduced to symbols of ownership and specialization. For example, breastfeeding is a natural and vital act - has been of spiritual and medicinal - with women in some cases are facing fines or harassment for doing it in public.

**SECTION C**  
AREA: 499,620 m<sup>2</sup>  
HEIGHT: 173 m

The neck, a vulnerable part of the body, symbolizes the connection between mental and physical identity. Placing a gym here critiques societal pressures on women to improve their bodies under external control while overlooking their intellect and vulnerability. With 15% of women feeling pressured by media heavily standards and the beauty industry profiting \$20 billion annually (Statista, 2019; Shrivastava, 2019), this placement highlights the suffocating weight of objectification and the imbalance between appearance and autonomy.

**SECTION G**  
AREA: 5,511,176 m<sup>2</sup>  
HEIGHT: 183 m

The lungs as an all-you-can-eat restaurant also highlight how women are forced to work harder while receiving less in return, reflecting the gender pay gap and economic inequality. Globally, women earn 20% less than men for the same work, and in many industries, they are concentrated in lower-paying roles despite contributing equally or more (OECD Women, 2022). This metaphor forces women to 'eat until they're full' metaphorically understanding the pressure to make up for lost income, especially as they often perform 76% of unpaid labor, such as caregiving and household work (ILO, 2017). The all-you-can-eat metaphor critiques this dynamic, showing how society takes and takes from women's labor while underplaying or outright refusing to fairly compensate these contributions.

**SECTION B**  
AREA: 1,321,176 m<sup>2</sup>  
HEIGHT: 98 m

The stomach as a factory symbolizes the societal exploitation of women's labor and bodies for endless productivity and consumption. Just like a factory churns out goods, women's bodies are often treated as tools to fulfill societal demands - whether through reproductive labor, caregiving, or maintaining beauty standards. For example, women are pressured to 'optimize' their bodies while sacrificing their own well-being, with 19 million girls under 18 going blind each year, often due to lack of access to education and autonomy (UNICEF, 2020).

**SECTION F**  
AREA: 1,843,000 m<sup>2</sup>  
HEIGHT: 87 m

Placing the government in the genitals critiques the historical and ongoing control over women's reproductive rights and sexuality. This placement symbolizes how patriarchal systems legislate and regulate women's bodies, often treating them as public property rather than private autonomy. For example, 49% of countries still restrict access to abortion in some way, and women's reproductive rights are frequently policed or applied retroactively (World Bank, 2020).

**SECTION D**  
AREA: 2,581,344 m<sup>2</sup>  
HEIGHT: 184 m

Placing the hospital in the uterus highlights the ongoing struggle for women's rights within healthcare systems. Despite making up 70% of the global healthcare workforce, women hold only 20% of leadership positions (WHO, 2021). Historically, women's health has been stigmatized and medicalized, often overlooking their needs and experiences. For example, women are more likely to have their pain dismissed, with studies showing 20% of women's pain is labeled as 'psychosomatic' compared to men's (JAMA, 2019).

**SECTION H**  
AREA: 2,416,560 m<sup>2</sup>  
HEIGHT: 79m

The hot chair shop in the legs symbolizes the reduction of women's worth to physical places for societal consumption. This placement highlights how patriarchal systems reduce women to parts meant to be used or sold. With restrictive laws forcing and media promoting hot seats annually from the hypersexualization of women, this metaphor exposes how society values women for their physical attributes rather than their individuality. Studies show that 55% of women feel their bodies are objectified in daily life (BBC.com, 2019).



# Radical house

Juan Pablo Díaz Hernández<sup>1</sup>

<sup>1</sup>Universidad Europea de Madrid, Spain

The project is located in a world after WWII exploded where humans no longer care about reconstruction and forget about the outside world, instead the communities and cities search for refuge in the underground, fully accepting the path of world destruction.

Architectural buildings are constructed underground, no more facades, no more design, just security and survival. The spaces created are tight spaces and the possibility of light is limited. Water is searched underground and rests of the past buildings cover and protect the new facilities from attacks.

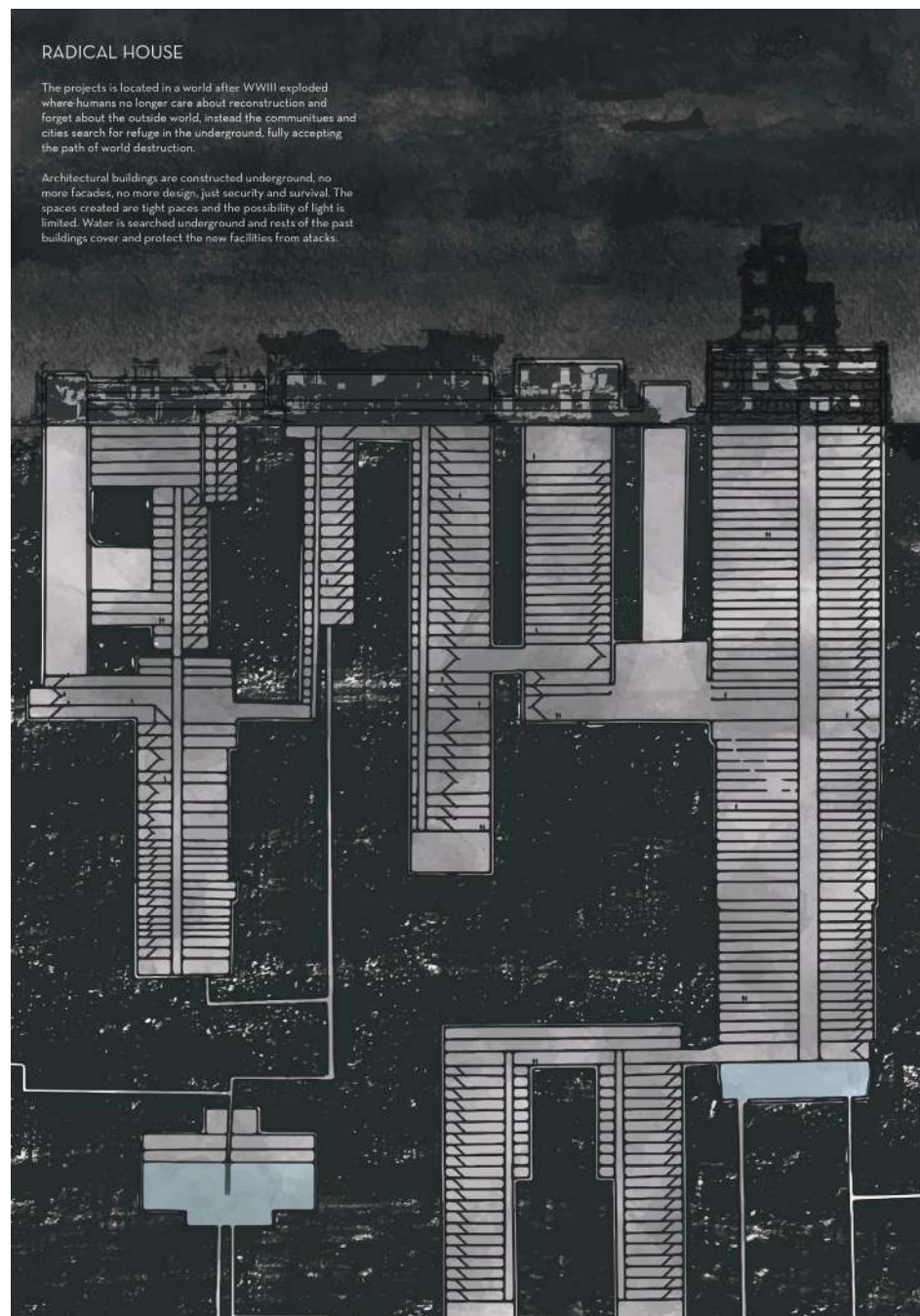

# Jahanam

Celeste Orteç<sup>1</sup>; Camila Gomez<sup>1</sup>; Fernando Salinas<sup>1</sup>; Adam Ihab<sup>1</sup>; Mariapaula Vigo<sup>1</sup>

<sup>1</sup>Universidad Europea de Madrid, Spain





# Litera

**Racse Ramos<sup>1</sup>; Sophia Obando<sup>1</sup>; Raquel Vidales<sup>1</sup>;  
Helen Gonzales<sup>1</sup>; Silvana Torin<sup>1</sup>; Ciro Ramirez<sup>1</sup>**

<sup>1</sup> Universidad Europea de Madrid, Spain

**Litera** is a proposal for a secluded, elevated city constructed atop the submerged remnants of our once thriving urban landscapes, which stands as a stark critique of our response to the climate emergency—a response that reinforces, rather than dismantles, structures of privilege. The proposal envisions Litera as an encapsulated city in response to catastrophic climate change, a fortified refuge from the rising seas as coastal cities, historical sites, and entire regions risk submersion. Encased in a protective dome, it shelters a select few from intensifying storms and rising waters, standing as a stark symbol of privilege in a divided world. Beneath this towering structure lies a haunting reminder of a lost human legacy and countless lives. A broken monument to humanity's failure to act collectively. The iconic, tall standing monuments, piercing the elevated slab, now serve as an ironic monument to a broken legacy, a structure once meant to unify but now marking the boundary between survival and abandonment. The ruins below: foundations of inequality

Beneath the shimmering dome of the new utopia lies a world in ruin, drowned by the apocalyptic tides of global warming. These submerged remains, a flooded underworld where the impoverished are forced to remain, act as the literal and metaphorical foundation of the city above. Here, the poor are condemned to exist as unseen pillars, supporting the elevated lives of those fortunate enough to



ascend. The flooded ruins below are not merely remnants of the past; they are a testament to systemic abandonment—a stark reminder that progress, for some, is built on the drowning hopes of others.

### The dome above: nostalgia as power

The encapsulated utopia above, protected from the elements by a shimmering dome, is a sanctuary for the fortunate. Yet, it is not free from the weight of history. At its core, the *sagrada familia* stands as a preserved relic, its spires piercing through the dome as a reminder of what once was. But it is not alone in its mission to tether the new city to the past. Surrounding it are modern replicas

of the buildings that were once part of the old cityscape—recreated not for function but for their symbolism. These imitations serve as architectural anchors, evoking nostalgia and preserving cultural identity amidst the disconnection of a radically new existence. This deliberate recreation of the old city's skyline underscores the paradox of utopia: while it strives to represent a fresh beginning, it cannot escape the longing for the familiar. These replicated structures, like the dome itself, are acts of preservation—but they also perpetuate a curated narrative of continuity. They reflect the selective memory of those who ascended, a way to carry forward their heritage while leaving the very people who embodied it behind.

### The *Sagrada familia*: a portal between worlds

The *Sagrada familia*, preserved in its original form and piercing through a great opening in the ground, serves as a bridge between the flooded ruins of the old world and the encapsulated utopia above. Unlike the replicated buildings in the new city that evoke nostalgia through imitation, the cathedral's unaltered authenticity transforms it into a profound symbol of continuity and sacrifice. Its spires, once beacons of faith, are now reimagined as a ladder to salvation, forcing those trapped below to make a harrowing ascent. At its summit lies a cruel choice: leap into the utopia above, risking survival, or return to the drowned chaos below. The cathedral becomes a crucible of resilience and worthiness, its spiritual symbolism twisted into a brutal test of desperation and hope. Embedded within the vertical architecture of this new society, the *sagrada familia* stands as both a physical and ideological connection between two worlds. For the privileged above, it is a nostalgic totem, a marker of identity and faith preserved amidst change. For the marginalized below, it is an unreachable promise, its spires symbolizing the threshold of an unattainable paradise. This act of preservation redefines the cathedral's role, turning it into a haunting reminder of what was sacrificed to build the utopia—a poignant monument to the divide between progress and those left to bear its weight.

### A hole in the sky: the *Sagrada Familia* as nexus

At the heart of this airborne utopia lies its most audacious feature: a deliberate void. The dome is pierced by a gaping oculus, aligning perfectly with the *sagrada familia*, which ascends through the structure like a blade through glass. This architectural gesture is a provocative leap of faith, a testament to barcelona's defiant spirit. The opening connects the earth-bound sacred with the futuristic profane, embodying a fragmented yet interconnected narrative of time and space.

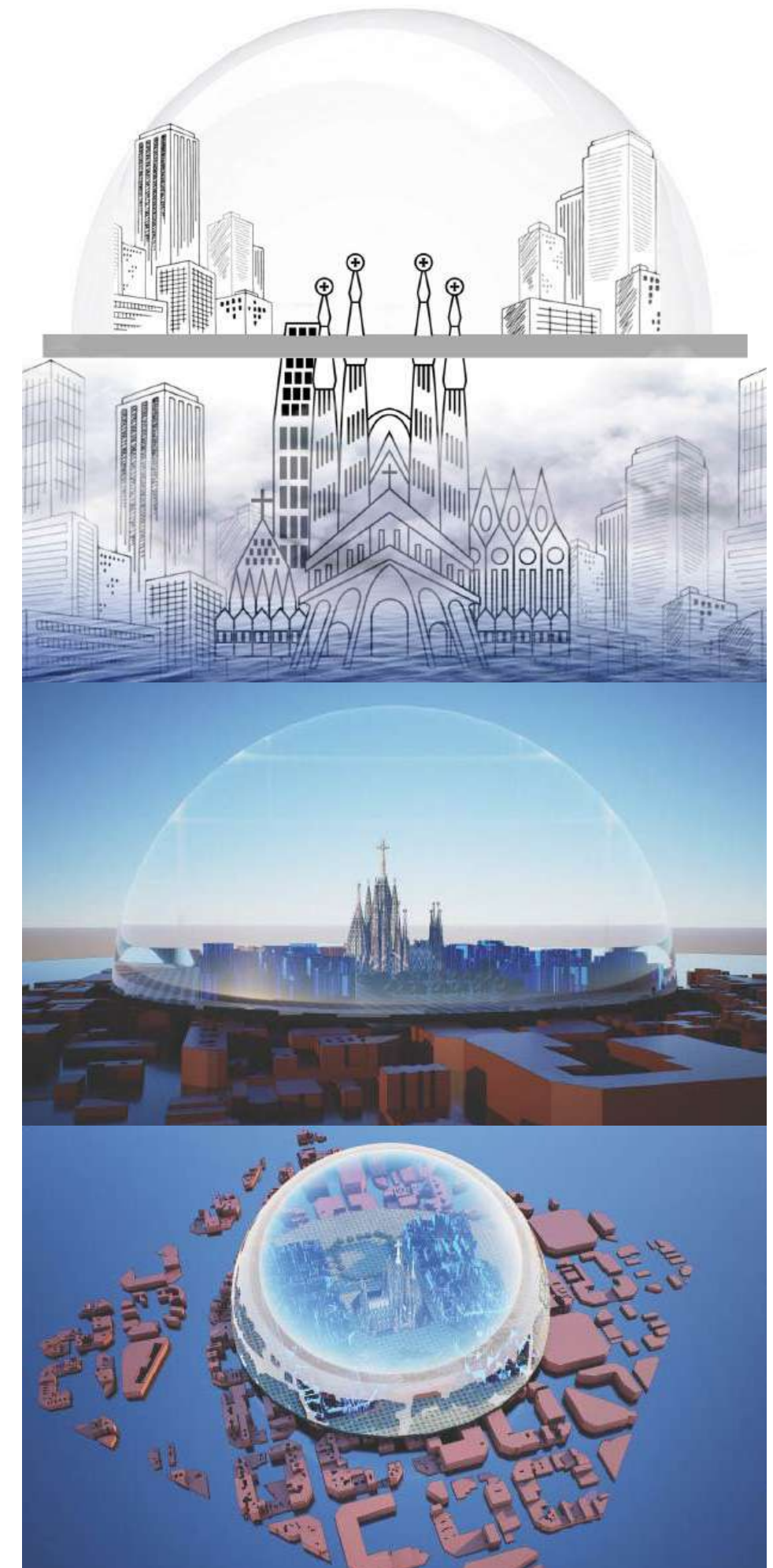



# Radical Architecture

Lucía Callatopa<sup>1</sup>; Mara Van Vliet<sup>1</sup>; Zoia Dolgova<sup>1</sup>; Aneta Báčová<sup>1</sup>; Lucia Strýčková<sup>1</sup>; Selina Untermair<sup>1</sup>

<sup>1</sup> Universidad de Alicante, Spain

## Tourism and Tragedy in Flood-Prone Areas

In Belén, a poor neighborhood in Iquitos, Peru, flooding takes over for half of each year. For the locals, this is a challenging reality they must endure daily. Yet, for tourists, it's often seen as a mere curiosity—a spectacle that remains detached from the socioeconomic struggles faced by the community.

## Dystopian Waterparks

The concept blends disaster tourism with aesthetics by creating a waterpark attraction in flood-prone areas. Inspired by Qatar's RIG 1938 water slide tower, the idea is to build a tall slide structure that only becomes accessible during floods, attracting tourists eager to experience and photograph the spectacle.

## POP-UP climate change adaptation

Project by Danish architectural office THIRD NATURE, who aims to adapt cities to the consequences of climate changes. Project deals with three challenges our cities face - flooding, parking and lack of green spaces. In the project the water reservoir is stacked under the parking facility. When heavy rain falls, water fills the underground reservoir and the parking structure will pop up in the cityscape, highlighting the adaption to the forces of nature. How does



architects respond to climate changes?

## Global prestige over basic needs

How does architecture relate to neoliberalism? The concept of a free market mean that architecture can be the equivalent of a sculpture and is alienated from the original social value of what architecture can bring to cities. When the focus is on the 'iconic' building that are there to boost a city's image and acts as a tourist attraction - it can mean global prestige can be prioritised over local needs. Is the purpose of architecture a sculptural profit margin? Or a social 'art' there to meet the needs of the people?

## The Floating Hotel "Ark" Concept by Remistudio

Originally designed as a flood-resistant building, the Ark Hotel is a proposed self-sustaining, floating structure that could withstand rising sea levels and serve as a refuge during floods. This building concept could double as a "floating disaster resort," where visitors can stay during extreme flooding, enjoying amenities while surrounded by water. The Ark is visually striking, almost spaceship-like, making it a potential magnet for those seeking both novelty and safety in catastrophic events.

## Floating Emergency Architecture by Vincent Callebaut

Known for his designs of floating

cities and flood-resistant buildings, Callebaut's work includes concepts like the "Lilypad," a floating ecopolis that can house 50,000 people. In a disaster-tourism twist, these futuristic floating communities could be marketed as refuge islands that only function or thrive when water levels rise. Such structures could be repurposed for tourism, with tourists staying on "emergency islands" surrounded by floodwater, blurring the line between shelter and luxury experience.

The visual elements we decided to mix was our concept of 'a waterpark amidst a natural catastrophe' specifically a waterpark that could only be enjoyed as a result of a flood. We wanted to visualise this idea as an 1950s style advert. The paradoxical visual elements of a waterpark - something associated with fun - be appropriate during a natural catastrophe and how does the architectural industry contribute to this?

## Key words

WATERPARK  
FLOOD  
GLOBAL PRESTIGE  
TOURISM  
DISASTER TOURISM  
VOYEURISM  
SPECTATORSHIP

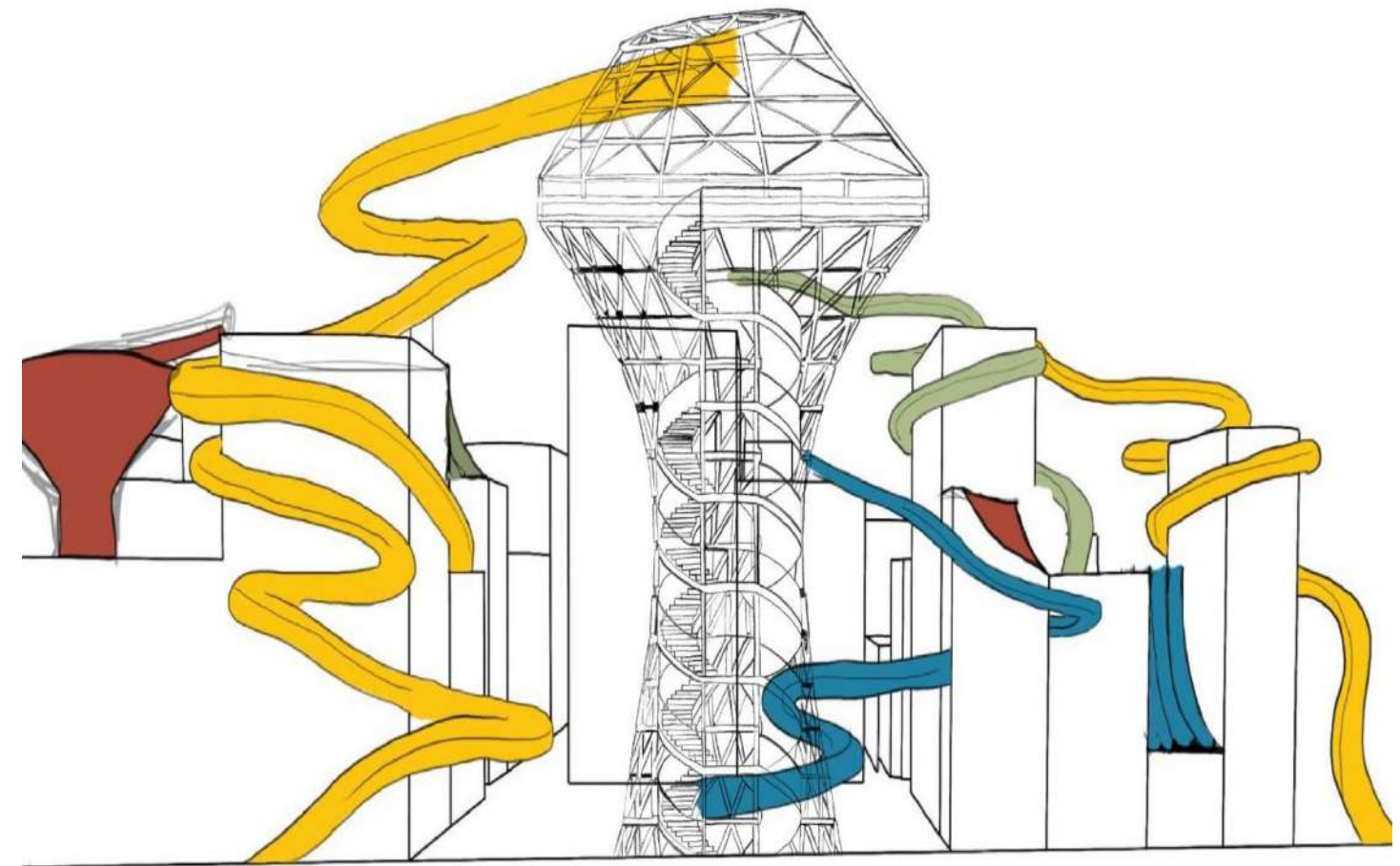
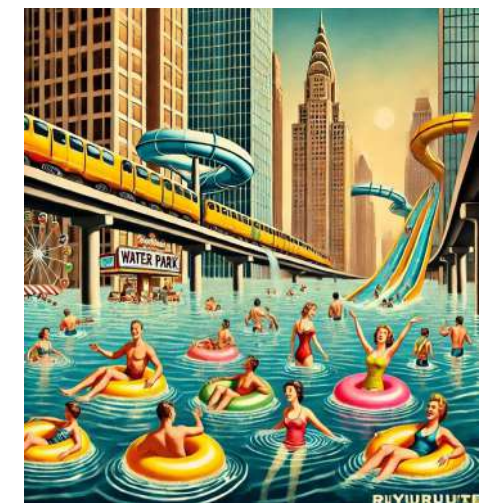



# All Separated together

Andrei Constantinescu<sup>1</sup>; Kenza Nakhli<sup>1</sup>; Javier Prados<sup>1</sup>; Rania Melehi Loudiyi<sup>1</sup>

<sup>1</sup> Universidad Europea de Madrid, Spain

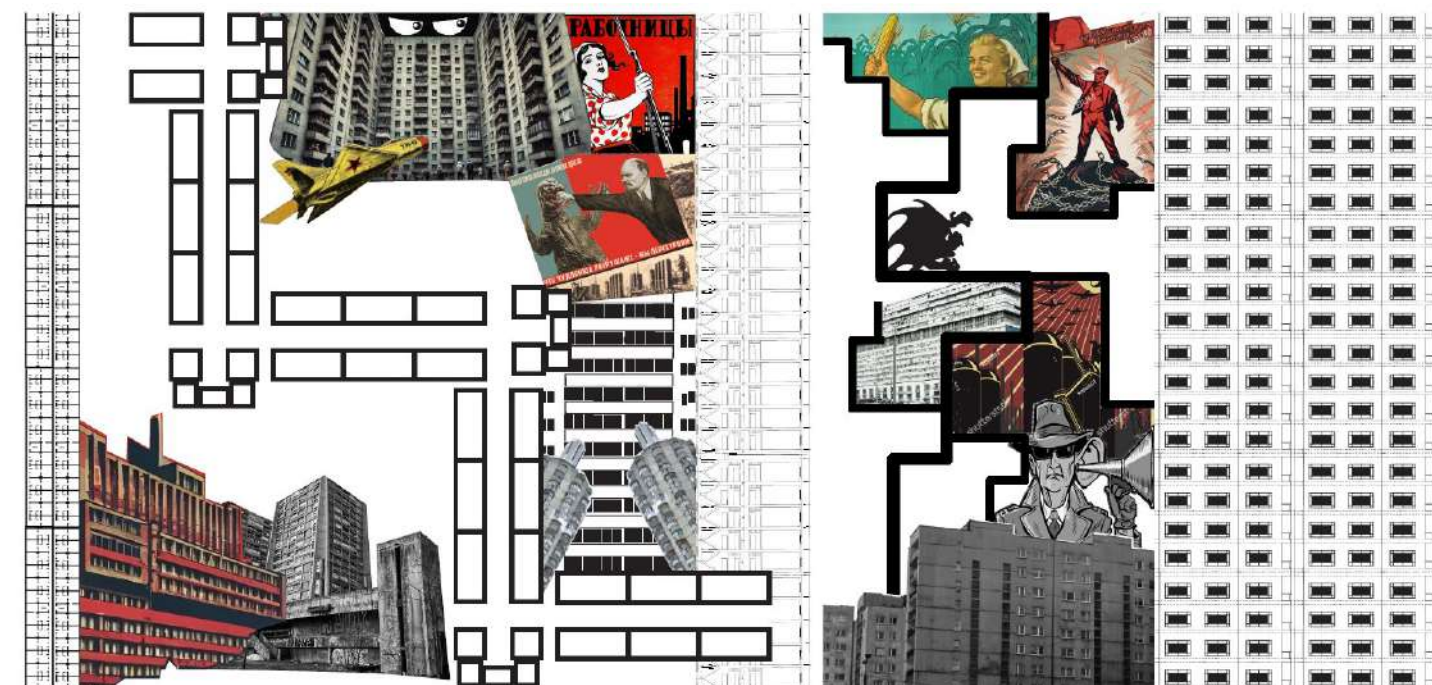
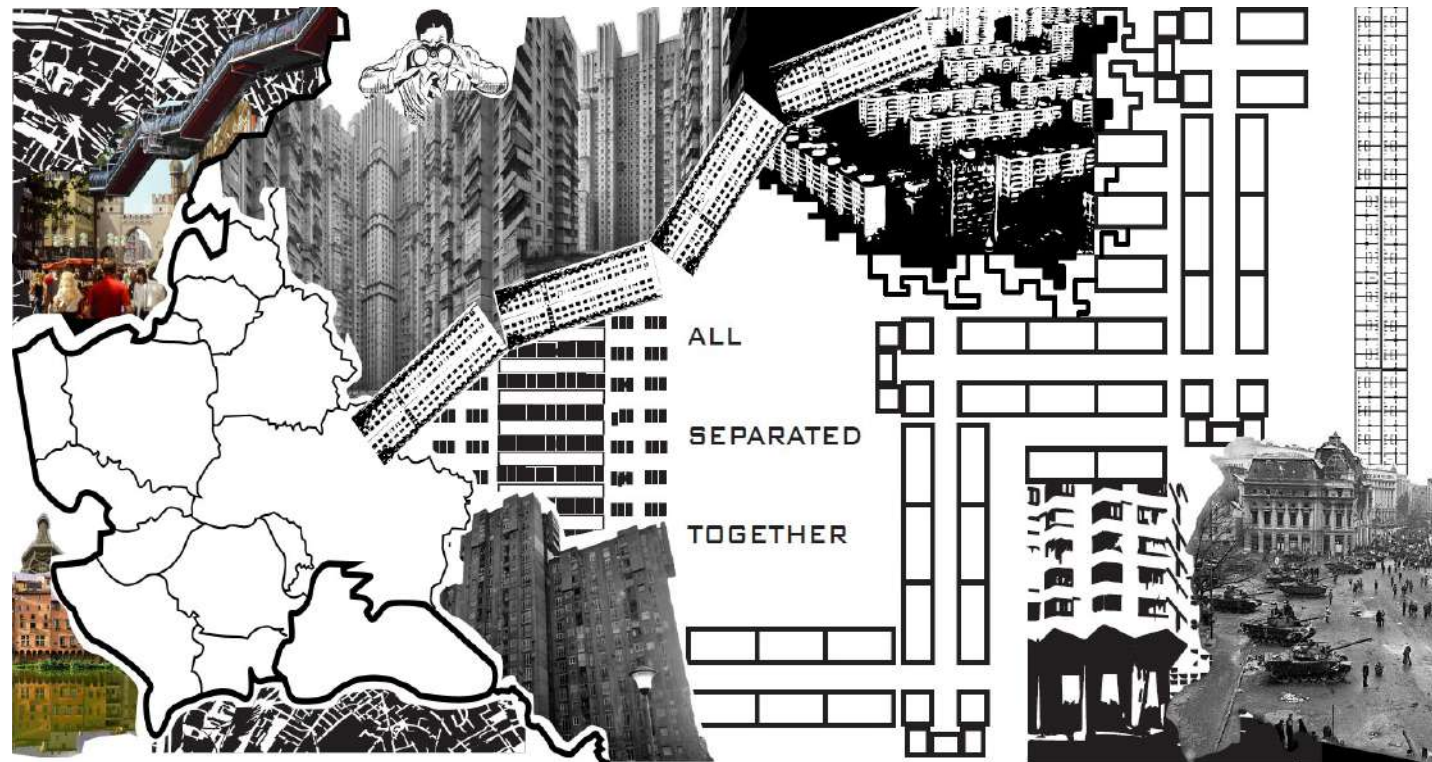

# Polluted landscapes

Esther Oliver Marín<sup>1</sup>; Gadea Vicente Caravaca<sup>1</sup>

<sup>1</sup> Universidad de Alicante, Spain

## CRITICAL REFLECTION

Human activities such as mass waste production and uncontrolled urban development deeply affect biodiversity and endanger the stability of ecosystems across the planet. The accumulation of polluting waste, from plastics to chemicals, not only degrades soil and water, but also generates toxic environments that alter the life cycle of countless species. These impacts are amplified in and around urban areas, where the expansion of cities has invaded and fragmented natural habitats, leaving many species without shelter or resources to survive.

Emblematic species such as the marbled teal, a critically endangered duck that inhabits wetlands, the samaruc, an endemic fish that struggles to survive in increasingly polluted waters, and the European otter, which depends on clean rivers and wetlands, have become visible symbols of this ecological crisis. The disappearance of any of these species is not only a tragedy due to the loss of unique life forms, but also highlights the cascading effects that can destabilise ecosystems. The loss of a single species can trigger imbalances that affect other plants and animals, altering food webs, disrupting natural pest control processes and deteriorating water and soil quality. These endangered species not only have intrinsic value that justifies their right to exist, but they play essential roles in the health and functionality of ecosystems. The Marbled Teal, for example, helps maintain the ecological balance of wetlands by controlling populations of aquatic invertebrates, while the Samaruc

contributes to the biological diversity of freshwaters, forming part of a complex food web that supports both predators and other aquatic species. The European otter, in addition to being a top predator that controls the population of certain fish, acts as an indicator of water quality; its presence suggests a healthy and balanced ecosystem. Together, these species not only contribute to the beauty and natural richness of environments, but are also key pieces in a larger system that affects the quality of life for all beings, including humans. In a world where urbanization is inevitable, architectural design must evolve to coexist with biodiversity, rather than displace it. This means that architects, urban planners, and city planners must adopt sustainable approaches that not only minimize environmental impact, but also promote the restoration and conservation of natural habitats.

The idea that architecture can coexist with biodiversity is not just an ideal, but an urgent necessity. Cities of the future must be designed with ecological resilience in mind, recognizing that humans are not separate from nature, but are part of an interconnected system. Incorporating nature-based solutions into urban planning not only protects biodiversity, but also improves people's quality of life, providing cleaner air, mitigation of extreme heat, and opportunities for a deeper connection with the natural world.

Ultimately, the evolution towards an architecture that respects and protects biodiversity represents a paradigm shift: a recognition that human well-being is intrinsically

linked to the well-being of all other forms of life. To ensure a sustainable future, it is essential that our cities and human developments integrate with nature, promoting coexistence and respect for the ecosystems that make our existence possible.

## DYSTOPIA

In a future where human activities have shaped the planet to the point of no return, cities have become monuments of uncontrolled progress, and ecosystems have been reconfigured by mass waste production and unbridled urban development. As humanity continues its destructive course, the landscape of colonized trash unfolds as a silent witness to the Anthropocene, an era marked by the indelible imprint of human beings on Earth.

Lagunas have been transformed into scenes of exclusion and decay. Wetlands that used to be refuges for biodiversity have been invaded and fragmented, abandoned to a fate of slow poisoning. However, in this desolate landscape of waste, something unexpected has begun to emerge: a web of adapted life, resilient organisms that find ways to thrive in what would once have been considered a graveyard of inert matter.

The marbled teal has been replaced by creatures that would not have existed without pollution as their primordial environment. The waters where the samaruc once swam in balance have mutated into chemical broths where anaerobic bacteria are the new rulers. The European otter, the top predator that kept rivers clean and orderly,



is now a distant memory, and its absence has left an ecological void that continues to expand, spilling over into chaos in food webs.

This displacement of biodiversity has made the concept of a balanced ecosystem a myth of the past. What was once destruction has become a laboratory. Polluted lagoons have been transfigured into experimental ecosystems, where new organisms struggle to redefine survival in a context that defies the laws of nature. These landscapes of exclusion have developed their own vitality, an ironic rebirth amidst the devastation.

Meanwhile, humanity suffers the consequences at its own hand. Metropolises have continued to expand, encroaching on fertile soil and habitats that once belonged to wildlife. Ecological corridors once promised as bridges for biodiversity have become sterile corridors, vestiges of a time when coexistence seemed possible. But relentless urbanization has consumed these

spaces, leaving fragments of nature trapped in preservation domes, where the last species are preserved as living relics, on display to remind us of what we have lost.

Architecture, now a grim art of containment and isolation, has evolved in response to the wounded planet. Buildings no longer integrate with the landscape; they control and subdue it. Structures, designed for productivity and isolation, rise as towers of domination, surrounded by waste belts where the original biodiversity has been supplanted by new hybrid and mutated life forms.

Thus, trash has become landscape, and architecture a tool of segregation. Cities have become closed ecosystems, a precarious balance of technology and altered biology, as the planet twists under the weight of civilization that has redefined the boundaries of what is life and what is death. In this world, everything is a matter of adaptation: survival is the only constant in a landscape that was once home and

is now an ecological battlefield.

### MANIFESTO

This manifesto is inspired by the fundamental connection between biodiversity and our human actions. It invites us to reflect on the impact of polluting waste generated by human activity and the urgent need to protect endangered species in the Anthropocene, with a special focus on our collective responsibility. But... why is biodiversity in danger?

a. Endangered species, such as birds, reptiles and endemic fish, are sensitive to changes in their environment. Their disappearance is a clear indicator of the environmental problems affecting our ecosystems, such as the wetlands of the Valencian Community and, specifically, the Lagunas de Rabasa. The decline of these species is a warning sign that reveals the cumulative impact of pollution and human activity.

b. These species play a crucial role

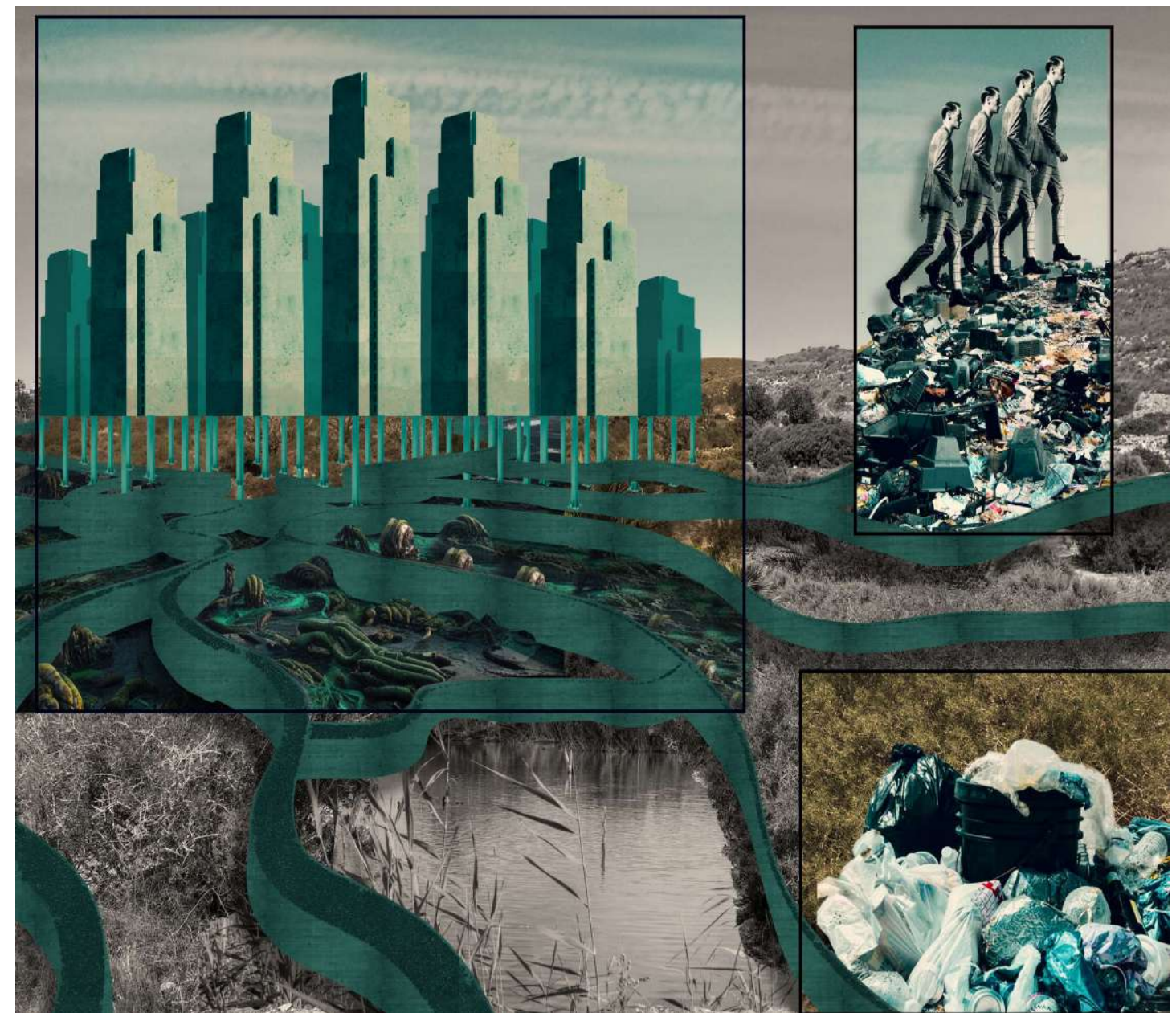

in maintaining ecological balance. For example, waterbirds such as the Marbled Teal control populations of insects and small organisms, while endemic fish such as the Samaruc and the Fartet are essential parts of food chains. In turn, these creatures are also a food source for predators such as the European otter and Bonelli's eagle. The alteration of their habitats directly impacts the entire ecosystem, increasing threats from invasive species and harming local biodiversity.

c. The presence of these species is like a symphony of nature that reveals the complexity and richness of life in wetlands. The song of birds, the movement of fish in lagoons, and the interaction of native plants are expressions of a living environment that is intrinsically connected to the health

of our planet. These sounds and signals remind us of the vitality of biodiversity, and the importance of preserving these natural areas in the face of advancing pollution and unsustainable development.

d. Environmental awareness and education are key. Endangered species must be included in educational programs and conservation efforts. Understanding their role in ecosystems can inspire future generations to value biodiversity, and to understand that these creatures not only have intrinsic value, but also importance in scientific research, from medicine to biotechnology.

So where do we, those responsible for urbanization and human development, come in? At this moment, architects and planners emerge as key players

in the protection of biodiversity. Although it may seem that architecture and biodiversity are disparate issues, there is a deep interrelationship between them. Architects can play an active role in preserving these habitats, designing structures and spaces that are respectful of the environment and that promote coexistence with endangered species.

It is time to recognize that biodiversity is an essential component of the balance of our planet! It is time to demand that stricter laws and regulations be enacted to curb pollution and protect endangered species! It's time to take concrete and urgent measures to reduce polluting waste and restore natural habitats, before it's too late! A collective commitment can make a difference.



# Permanent consumption

Yasmine El Bada<sup>1</sup>; Franz Schubert<sup>1</sup>; Aron Schönfeld<sup>1</sup>

<sup>1</sup> Faculty of Architecture, University of Budapest, Hungary

## PLUG-IN-CITY by Archigram 1964

### Modular Megastructure

Plug-In City envisioned a massive, adaptable framework where individual modular units, like residences or offices, could be "plugged in" and replaced as needed.

### Flexibility and Change

The structure allowed for constant upgrades and modifications, opposing traditional, fixed architecture and promoting flexibility.

In Plug-In City, Archigram critiqued consumerist society by proposing a flexible, modular city where buildings could be continuously adapted rather than replaced. This design resisted wasteful cycles of planned obsolescence by emphasizing longevity and adaptability over traditional, static architecture. Archigram promoted shared infrastructure and collective use of resources, challenging the consumer-driven focus on private ownership and suggesting that architecture should serve people's changing needs, not act as disposable products.

## NEW BABYLON by Constant 1959-1974

The question of how people might live in a society free from famine, exploitation, and work—a society where everyone could freely express their creativity—sparks the vision of an environment radically unlike any that architecture has ever realized.

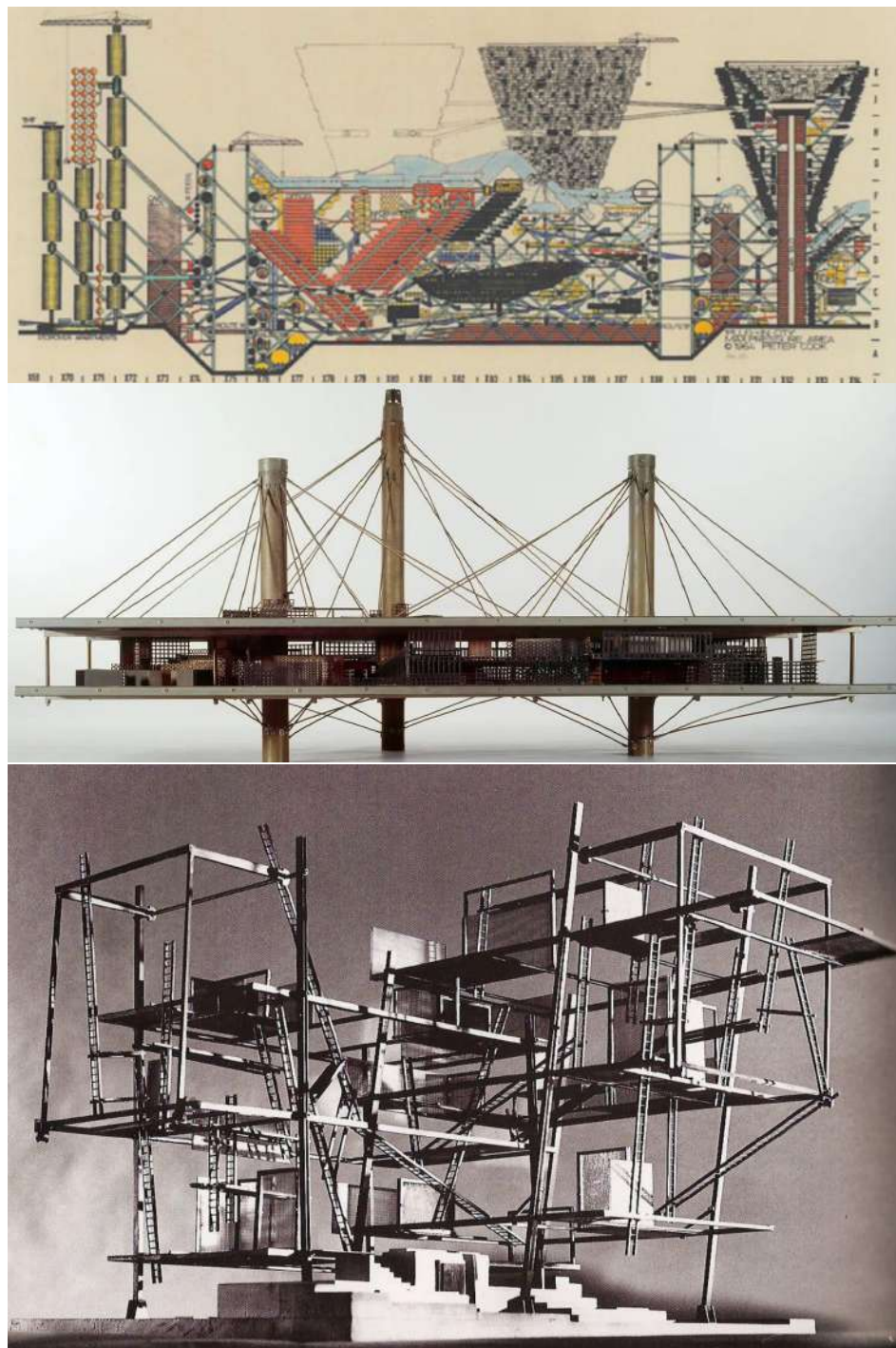

## SCENARIO / ACTION 1

### 'The fast Burger'

Your enter fast food restaurant and standing in front of a huge screen. You're scrolling down all the special offers. Everything is double, super, max crazy. Double beef sounds perfect. You're paying with your phone while getting a new instagram Meme from your internet friend. At the same moment the radio in the store is broadcasts the hottest news about war, climate crisis and the newest celebrity drama. And the weather. Meanwhile the food is brought to your table. You look up a second - Thank you. You take two huge bites from your double beef burger. Hmm... Subconscious your swiping on your Home Screen and ending up clicking on instagram. You scrolling down until you see an advertisement about the new Xbox Game. A fictional world to escape the reality. Why not, you order the game. At this time you finished your burger. That was fast. Was it really that good? Can't really remember anymore. You're open up Google maps to find you way home while putting in your headphones to listen to a podcast about the upcoming football game.

## SCENARIO / ACTION 2

### 'The Loop of Infinite Cravings'

Description: The action takes place in a room designed like a modern shopping mall, but completely without windows and with endless mirrors. There are



consumer objects in the room: Small appliances, clothes, toys, screens showing endless product images and messages. Participants can take the objects and carry them around, but nothing really belongs to them - there is no exit and no way to leave the room with anything.

### Procedure:

1. Entry: visitors enter the room individually and are given a digital wristband that records every grab for an object and every interaction with the screens.
2. Interaction with the objects: Participants are surrounded by enticing consumer objects that they can examine, touch and 'acquire' without ever actually owning anything.
3. Constant bombardment and sensory overload: Screens broadcast messages, adverts and social media notifications in rapid succession - a symbolic stream of information overload.
4. Decay of objects: After a while, the objects in the room begin to gradually lose their lustre and disintegrate to illustrate the transience and wear and tear of consumption.
5. Endless loop of interaction: The digital wristband regularly reminds participants of their 'interaction statistics' - how many objects they have touched, how often they have looked at screens and how much attention they have focussed on things that ultimately have no

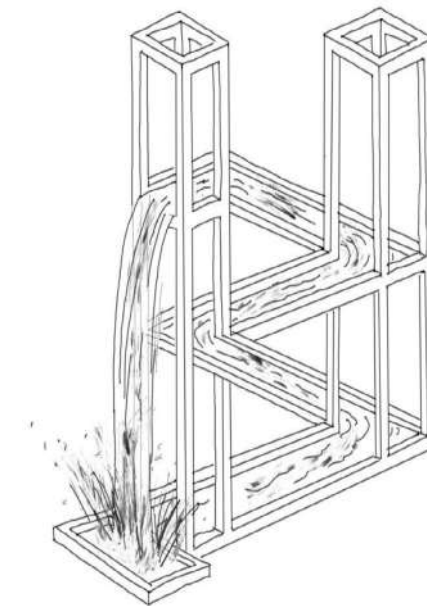

meaning or use.

Objective: The activity aims to encourage participants to reflect on their own behaviour towards consumption and information overload by experiencing their interaction with endless and pointless consumption in real time and understanding how this can lead to a feeling of emptiness and dependency.

## MANIFESTO

The artwork depicts a monumental structure in the shape of an endless loop, hovering above a natural landscape. This imposing form clashes starkly with its surroundings, appearing disconnected and alien in the open environment. The surface is plastered with advertisements, reinforcing its artificial nature.

Peering inside through cutouts, we see consumers confined to windowless spaces with no connection to the outside. These rooms are packed with an overwhelming array of consumer goods, while large screens continuously bombard them with advertisements and messages. Entire walls are covered in mirrors, meant to encourage self-reflection, yet they amplify the sensory overload and intensify the endless barrage.

In sharp contrast, the surrounding landscape is calm and inviting—a serenity ignored by the consumers trapped within the perpetual cycle.





# WS3 Madrid / Radical present

Noah Pashkevich<sup>1</sup>; Max Darwall<sup>1</sup>; Leonhard Sigmund<sup>1</sup>;  
Nina Lüdtkke<sup>1</sup>

<sup>1</sup> Universidad de Alicante, Spain

## RESEARCH

### Drop City (1965-1973)

Drop City was a groundbreaking 1960s commune in Colorado that embodied utopian ideals of communal living, creativity, and environmental consciousness. Founded by artists and students seeking to "drop out" of mainstream, consumer-driven life, the community rejected hierarchy and embraced shared work and simple living. Inspired by Buckminster Fuller's geodesic domes, they built their own structures from salvaged materials, transforming Fuller's ideas into DIY, sustainable housing. Though short-lived, Drop City's experimental approach influenced future ecological design and communal projects. Its legacy continued through initiatives like the Whole Earth Catalog and the sustainable architecture of Zomeworks, leaving an enduring mark on countercultural and environmental movements. <https://westernartandarchitecture.com/features/the-rise-and-fall-of-drop-city/>

### Plan for an underground nuclear shelter, Oscar Newman (1969)

In 1969, architect Oscar Newman proposed an ambitious and surreal project: an underground city beneath Manhattan, created by detonating nuclear explosions to hollow out massive spheres in the bedrock. This "atomic city" would house a grid of streets, buildings,

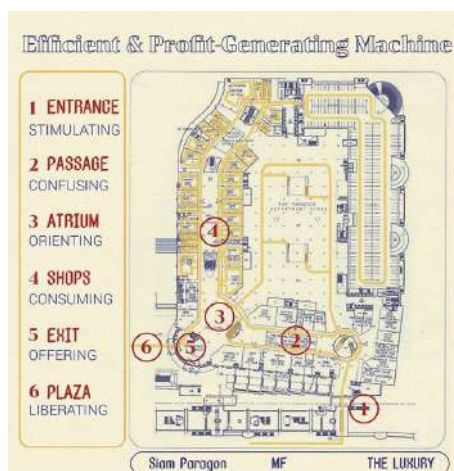

multi-level spaces, and large air filters reaching the surface to combat issues of air and views. Newman envisioned a series of such spherical underground cities, each around 1.2 cubic miles in volume, beginning 1,200 feet below Times Square. The excavation would be monumental, requiring diversion of the Hudson and East Rivers and extending into New Jersey. Though never realized, the project remains a striking example of radical urban planning concepts

<https://socks-studio.com/2012/08/18/oscar-newmans-undeground-city-beneath-manhattan/>

### Temples of Consumerism, Pin Sangkaeo, 2022

Temples of Consumerism: Undertaking Thailand's Political Tactics through Bangkok Shopping Mall investigates the role of shopping malls as physical tools of maintaining the status quo, used by those who hold political powers in order to superimpose their ideologies on the collective citizens and perpetuate the systems. The state adopted merit-making from Thai Buddhism during the Cold War as a response to the outside insurgency of the communist threat. It was used as a rebranding tactic to offer people a sense of security, protection, and abundance while subtly asserting the monarchy at the top of the religious and political hierarchy. Merit-making has commonly been practiced among

Thai Buddhists in everyday life through the physicalized religious artifacts in the urban fabric and has become part of the population's daily lives until today. As religious lifestyles become irrelevant, the modern Thai middle-class citizens take place in a new form of merit-making through shopping at the malls, which have completely replaced the temple's role as the primary public space. Malls became the new temples that seemed secular and nonpolitical while subtly asserting the corporations on top of the hierarchy.

The shopping malls in this site are composed of regulating tactics and strategies designed to optimize this massive volume of profit-generating machines and amplify the grandeur of the merit makers. Since the shopping mall world depends on the imaginary of being a safe and enjoyable space, it must be protected and secured against any alien element breaking this illusion. Escalators add the diagonal dimension to the experience and deny the distinction between separate compartments and floors, which are limited by the structural logic of the building and are the primary regulating mechanism that has shaped shopping mall design to be as efficient as they are today.

<https://archinect.com/features/article/150315200/architecture-consumerism>

### Ant Farm (1968 - 1978)

Inspired by the counter-culture milieu of the Bay Area, Chip Lord and Doug Michels founded Ant Farm in 1968. While the group's initial focus was on reforming architectural education, their work soon expanded into a tool for deeper introspection and critique propelled particularly by the Brutalist architecture of Louis Kahn and Paul Rudolph. Through performances, installations, videos, manifestos and agitprop events replete with their own inflatable structures, they celebrated flexibility and lightness; these ideas eventually culminated in the design of The House of the Century.

Subsequent projects, like the famous Cadillac Ranch Show, Media Burn and Dolphin Embassy,

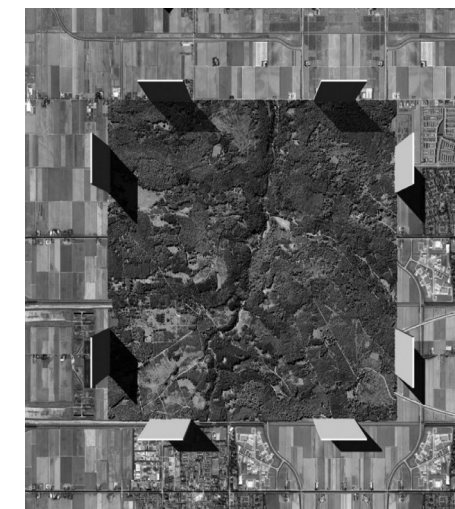

also served as a tongue-in-cheek comment on mass consumption, production and the resulting environmental depreciation. As if all this was not enough to satisfy the cheeky spirits of the duo, a customized Chevy called Media Van accompanied them throughout their travels across the United States.

## BLOODLINE

### No Stop City, Archizoom Associati (1969-1972)

No-Stop City is an ironic critique of the ideology of architectural modernism taking onto its absurd limits:

"The real revolution in radical architecture is the revolution of kitsch: mass cultural consumption, pop art, an industrial-commercial language. There is the idea of radicalizing the industrial component of modern architecture to the extreme.

### Stop City, by Dogma (2007-2008)

By assuming the form of the border that separates urbanization from empty space, Stop City is proposed as the absolute limit, and thus, as the very form of the city. Stop City develops vertically. Stop City is an archipelago of islands of high density.

The growth of Stop City happens by virtue of its limit, i.e. by the punctual repetition of the basic unit, which is a city of 500.000 inhabitants made of eight slabs measuring 500 by 500 meters, 25 meters thick. These eight slabs are positioned on the border of a square with side length of 3 kilometres, thus demarcating an "empty" area.

Each slab is a "city within the city", an Immeuble Cité that is in itself a self-sufficient city not characterized by any specific program or activity, being the support of multiple programs or activities.



### Bibliothèque nationale de France, Le site François-Mitterrand (1996)

The site was designed by architect Dominique Perrault, and construction was completed in 1996. The design features four large glass towers arranged in the shape of an open book, symbolizing the library's role in preserving knowledge. These towers are often referred to as the "four books" of the library. The complex also includes a central garden and a modern, expansive reading room.



### Whittier, Alaska

Example of a city that more or less only is one big building. Whittier is notable for its extremely wet climate, as well as for the fact that almost all of its residents live in the Begich Towers Condominium, earning it the nickname of a "town under one roof".



### MANIFESTO

For centuries we humans have claimed nature's resources as our own. We conquered her land, drank her water, ate her flesh and shat in her rivers. We took advantage of every inch we could get our hands, boring into the deepest depths and monetizing up to the last breath of fresh air. And one day, nature rejected us. The rain turned acid, the sun began to bake and and the last breath of fresh air turned our lungs to ash.

What did we learn? It is our nature to destroy. We are too full of greed, too much of our own mind and obsessed with ourselves. We are incapable of caring for the precious gift that is nature. Therefore, we must separate ourselves from her. The forbidden fruit, may look upon her in wonder and appreciate her in all her splendour. But we may not taste the crisp sweetness of her fruit lest we once again be cast out from eden and become victim again to our own vices.

So we built new structures.

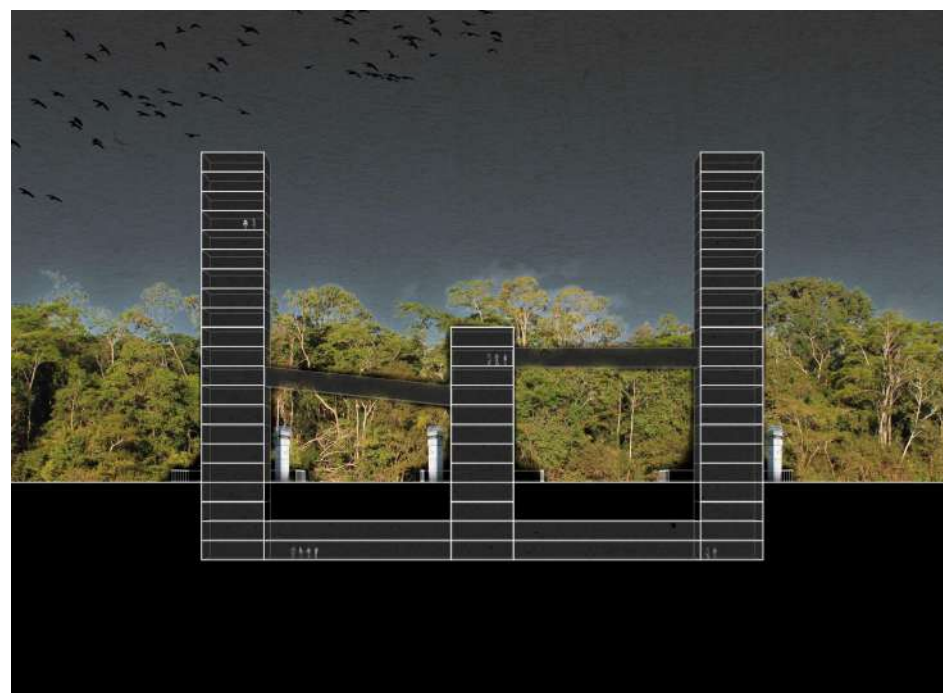

# Radical statement

## Emanuele Quinz<sup>1</sup>; Marco Pace<sup>2</sup>

<sup>1</sup> Full Professor, Université Paris.  
emanuele.quinz@gmail.com

<sup>2</sup> Artist.  
marcopacestudio@gmail.com

Radical architecture and design in the 1960s gave us examples: Andrea Branzi, Gianni Pettena, Ettore Sottsass and others should not be seen as masters but as pioneers who explored paths that are still relevant today. The important thing is, today as then, not only to radicalise architecture but to root it, to return to its root: nature, which is both landscape (metaphor) and territory (habitation). In this radical perspective, art is not installation, architecture is not institution, design is not instigation, but they are all part of the same existential strategy, of settlement.

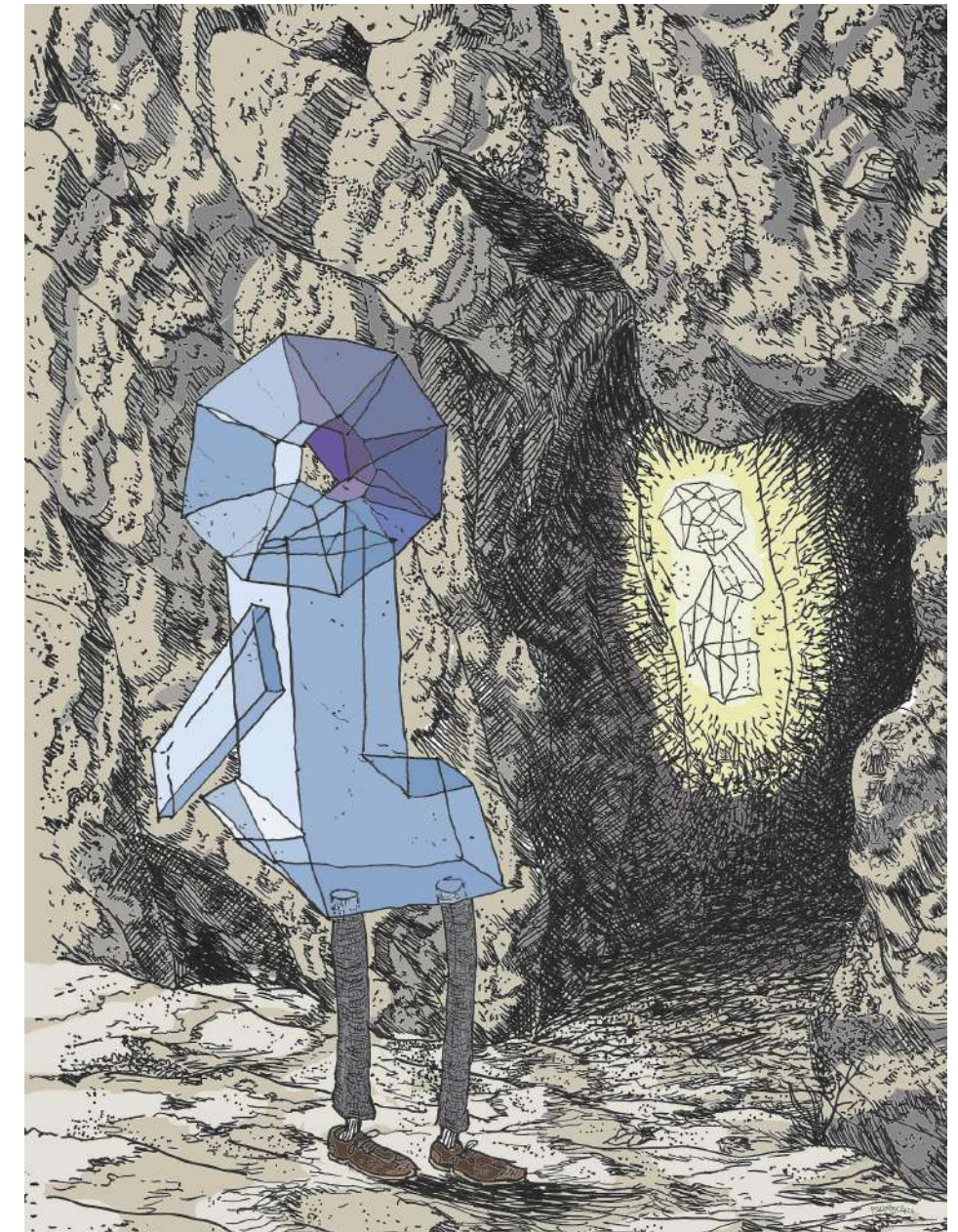

Fig.1 - Drawing, Marco Pace.



# The Danger of a Simple Story

Mads Hvidkaer Christofersen<sup>1</sup>

<sup>1</sup> Umeå School of Architecture, Sweden  
mads.c1998@gmail.com

With very few materials, a small-scale intervention depicts a future dystopia where living underground is necessary due to growth-oriented regenerative developments – essentially new-built houses that no one can afford to live in. And like true architectural 'studs,' the solution is simple; grab a shovel and dig yourself a hole for cultural heritage and living. In *STUD: Architectures of Masculinity*, patriarchy is depicted through architectural experiments, among them Matthew Bannister's *Badlands Health Club* (Sanders, J. 1996 p. 210-215) that seamlessly weaves sequences of grey spaces into what looks like a dystopic underground man-cave. However, by claiming space in soil, and by that ignoring all external factors, such as wind and weather, the spaces foster a dreamy and delightful world. This project finds itself within a North Swedish context where new houses and neighbourhoods are popping up everywhere. Surrounded by construction sites, it breathes ideal rather than real – reaching far down into the void.

## Criminal capitalists and cracked windows

In this project, plastic tarps and temporary wooden structures, often seen in urban areas with many construction sites, are a metaphor for neighbourhood disorder caused by capitalist private developers. Visually whitewashing neighbourhoods for looks and value. In 1982, James Wilson and George Kelling used the Broken Window Theory to explain how petty crimes led to more serious crime in certain urban areas (McKee, 2024). A series of events that amplify one another – escalating from innocent to inhumane. Wilson and Kelling saw that areas with more graffiti were more likely to face more robberies – but are they also more likely to face demolition and regenerative developments?

As of now, one can only speculate why plastic tarps, temporary wooden structures and innocent graffiti might lead to gentrification, which, through the eyes of Wilson and Kellings' theory, should be considered a final stage of urban disorder.

## How did planning become so growth-oriented?

Urban planning is a discipline of distributing land and money, and in post-war welfare states like Sweden, the tools were developed to fight income equality among regions. Improved standard of living urged the need for regulatory mechanisms, and it has essentially shaped our cities into what they look like today (Galland, 2012, p. 538). But since the 1980s, we have seen a shift towards regional planning that aligns with pursuit of economic growth, enabled by neo-liberal political agendas – possibly with Margaret Thatcher leading the way. In arenas of multiple resourceful stakeholders, regulatory police instruments are significantly weakened, if not completely useless, and according to Galland this creates a "soft space of governance, that put the established regulatory tools, fitted for local planning, out of play" (2012, p. 536-37).

At Lasarettbacken in Umeå, where this project emerges, multiple stakeholders of (mainly) commercial interest are building a new city centre – essentially the old hospital area – and this requires a large-scaled detail plan to be politically approved, since it overrules several old (and smaller) detail plans (see *Stadsliden 2:3 – hamrinsberget*). The

legal infrastructure is simply not suited to support such projects, and although other actors, like Västerbottens Museum, stressed the cultural significance of the area (Berglund L. 2020), demolition has already started.

## References

- Sanders, J. (1996). *STUD: Architectures of Masculinity* (First edition). Princeton Architectural Press.
- Umeå kommun. (2014). *Stadsliden 2:3 – hamrinsberget* [detail plan currently being assessed].
- Lena Berglund. (2020). *Sofiehem 3-12, museets yttrande*. [DNR 876/20]. Västerbottens Museum.
- McKee, A. J. (2024, August 30). *broken windows theory*. Encyclopedia Britannica. <https://www.britannica.com/topic/broken-windows-theory>
- Galland, D. (2012). *Is Regional Planning Dead or Just Coping? The Transformation of a State Sociospatial Project into Growth-Oriented Strategies*. *Environment and Planning C: Government and Policy*, 30(3), 536-552. <https://doi.org/10.1068/c11150>

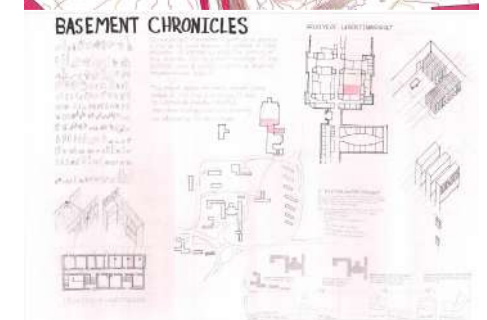
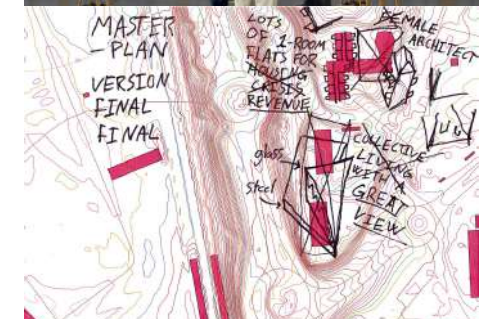
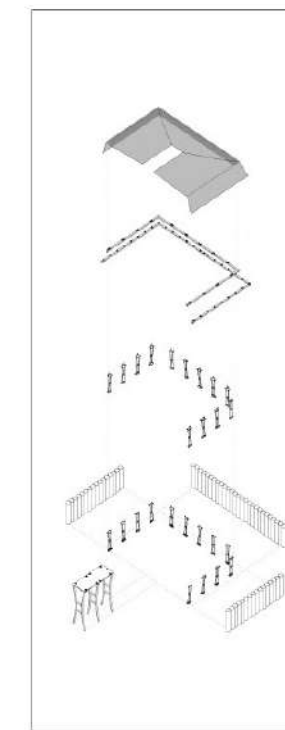
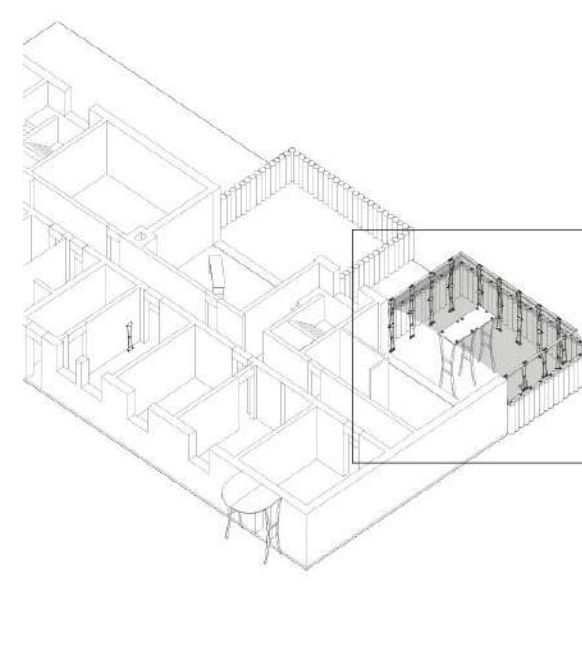
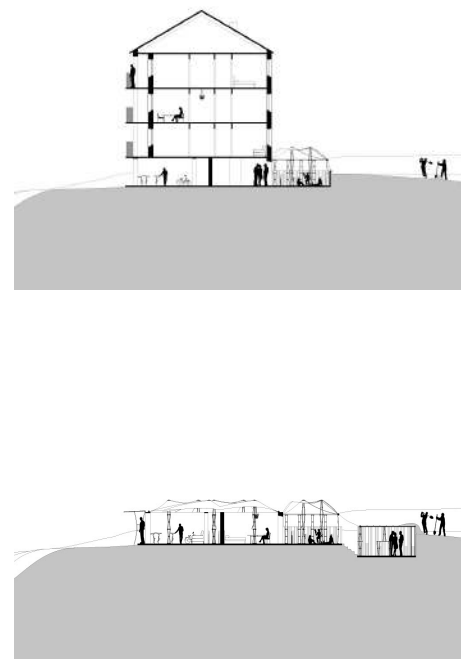



# Landscape projects in Cairo

George Azer<sup>1</sup>

<sup>1</sup> Università Mediterranea di Reggio Calabria, Italy  
georgrafik717@gmail.com

Cairo, a bustling metropolis at the base of the Nile Delta, has been shaped by various rulers over the years, resulting in its unique mosaic of districts. Recently, the city has undergone significant transformations due to its rapidly growing population. Land grabbing has severely impacted agricultural areas, while conventional urban solutions—such as newly constructed highways, railways, and public housing—have further altered the landscape. The shift towards accommodating vehicles has led to a drastic reduction in green spaces, with residents having just 0.74 m<sup>2</sup> of green space per capita as of 2020. In response, the city is developing a new mega-capital in the desert, alongside numerous private housing projects.

This research explores an alternative approach through the creation of a radical urban agriculture park on the periphery of the densely populated Imbahah district. To address the dual challenges of increasing green public spaces and reclaiming agricultural areas, this project proposes an urban agriculture garden consisting of public green areas, semi-private agricultural lands, and private agricultural plots. Central to the design is a structure inspired by historical radical works, particularly those of Boullée and Piranesi.

Boullée's imaginative megastructures, often incorporating trees for scale, reflect the precision of nature in agricultural design. Conversely, Piranesi's *Le Vedute di Roma* depicts a seamless integration of architecture and nature.

Drawing from these inspirations, the project features a contemporary structure modelled after the stepped pyramid of Djoser, incorporating a vertical urban garden on its exterior and a hydroponic farm within. The structure's exterior steel frame supports the vertical public garden, while the main beams carry the floors of the vertical farm, suspended by steel cables within a fabric envelope that allows indirect sunlight to permeate the interior. This design aims to merge historical references with modern urban agricultural solutions, providing both a functional and symbolic reclamation of green space and agricultural practice.

The selected site, previously an airport and now used for pre-casting concrete beams for bridges, was once surrounded by agricultural lands that have since been subjected to land grabbing. The site is divided into three zones: an ongoing public housing project, an existing park, and the proposed project site. The project aims to restore agricultural practices to the district's residents, offering both sufficient food production and green open spaces for various cultural activities.

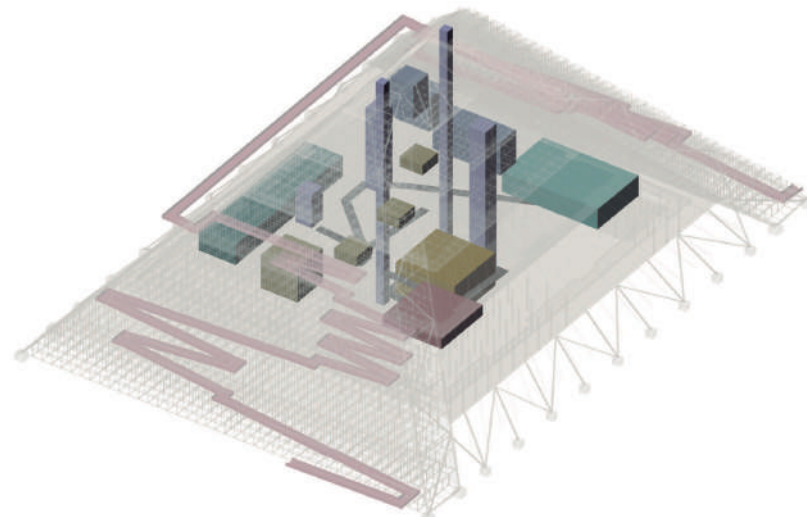

Storage / Elevators / Library / Processing / Laboratory / Worker Space / Services.

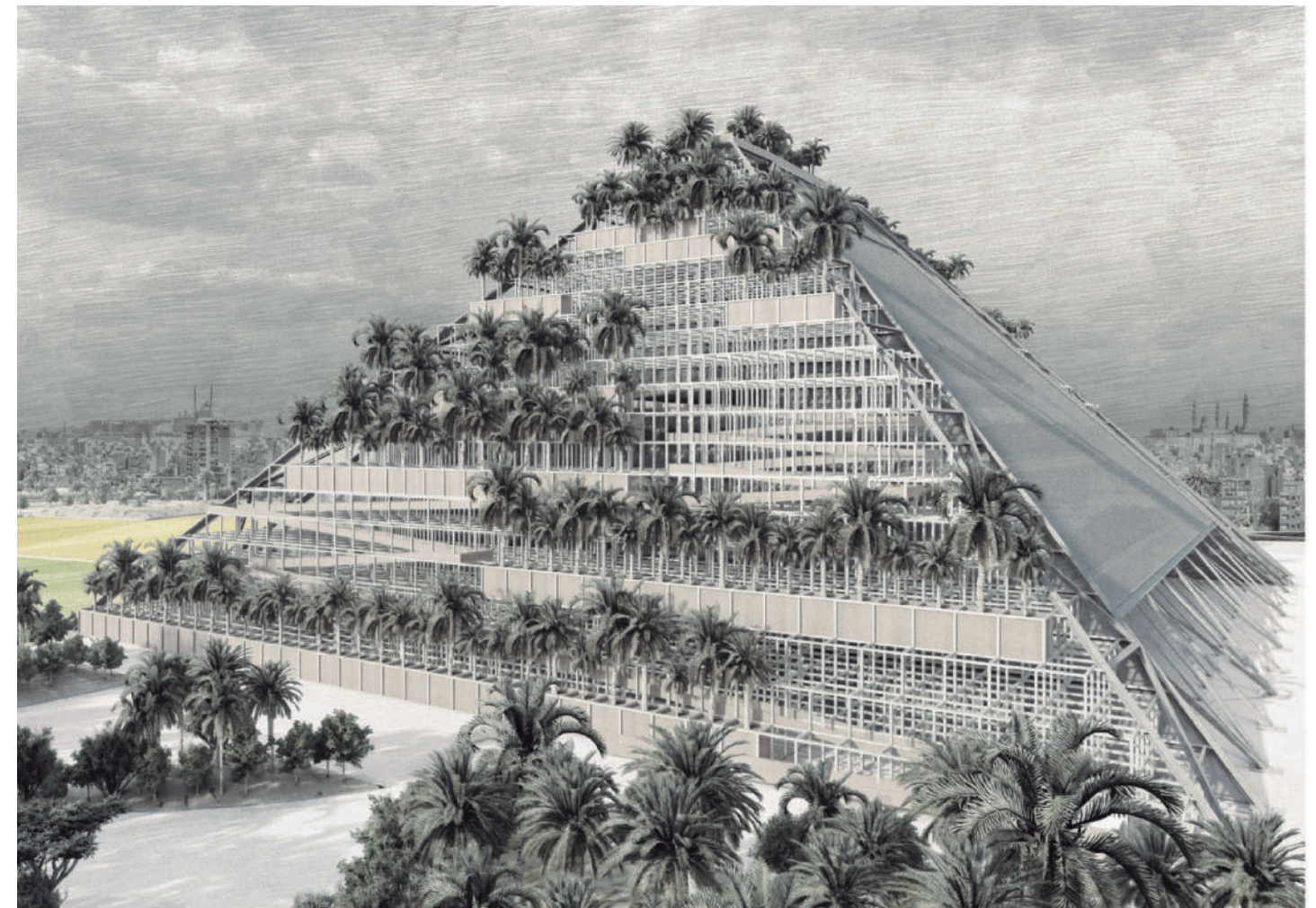



# Tabarca: A Planetary Indigestion

Reflections on the Blended Intensive Programme (BIP – ERASMUS+) 2024

Sánchez Merina, Javier<sup>1</sup>; Alvado Bañón, Joaquín<sup>2</sup>

<sup>1</sup> Department of Graphic Expression, Design and Projects, Alicante University, Spain.  
<https://orcid.org/0000-0003-1973-690X>  
jsm@ua.es

<sup>2</sup> Department of Graphic Expression, Design and Projects, Alicante University, Spain.  
<https://orcid.org/0009-0007-8304-0831>  
joaquin.alvado@ua.es

This article is based on the project funded by the European Union for the organization of the Erasmus+ Blended Intensive Programme (BIP) "Rural Areas Facing Climate Change." The participating institutions in this BIP included the University of Alicante, Université Catholique de Louvain, École Nationale Supérieure d'Architecture de Montpellier/La Réunion, Karlsruher Institut für Technologie, and the Oslo School of Architecture and Design. The program focused on collaborative work conducted on Tabarca Island (Alicante) in 2024.

Citation: Sánchez Merina, J.; Alvado Bañón, J. (2024). "Tabarca: A Planetary Indigestion", UOU scientific journal #08, 194-199.

ISSN: 2697-1518. <https://doi.org/10.14198/UOU.2022.8.17>  
This document is under a Creative Commons Attribution 4.0 International license (CC BY 4.0)



Fig.1 - Initial phase at Alicante University.

**This article examines "A Planetary Indigestion," a workshop developed during the Blended Intensive Programme (BIP – ERASMUS+) 2024 titled *Rural Areas Facing Climate Change*. Coordinated by the Department of Architectural Projects at the University of Alicante (Spain), this international collaboration brought together architecture schools from Université Catholique de Louvain (Belgium), École Nationale Supérieure d'Architecture de Montpellier / La Réunion (France), Karlsruher Institut für Technologie (Germany), and Oslo School of Architecture and Design (Norway) to explore climate-related challenges on Tabarca Island, Alicante.**

**The program, which involved 60 participants, faculty and students, combined seminars, workshops, and on-site activities from April 4th to April 11th, 2024, addressing sustainable strategies for remote rural areas in the context of climate change.**



## PROGRAMME OVERVIEW

The Blended Intensive Programme (BIP) aimed to foster a multidisciplinary exchange of perspectives on the challenges facing remote territories in the context of climate change, new rurality, and sustainability. Responding to the urgency of protecting natural reserves from significant human impact, this program adopted a research-by-design methodology to examine the balance between safeguarding fragile ecosystems and addressing the needs of human settlements.

The issues addressed in the 2023 iteration of the program in the Mafate Circle, Réunion Island, were revisited and recontextualized for Tabarca Island in 2024. Comparative analyses of these two geographically and culturally distinct sites provided an opportunity to reflect on critical themes, including water management, food and



energy autonomy, and the interplay between ecology and economy, as well as the relationship between built and natural environments. This approach sought to uncover innovative strategies for rural development across diverse contexts.

## INITIAL PHASE: Seminars and Foundations

The program commenced at the Alicante University Museum (MUA) with a series of lectures delivered by local professors Miguel Mesa, Juan Carlos Castro, and Arturo Calero. These sessions presented architectural research by students from the University of Alicante, demonstrating creative approaches to mitigating global warming through innovative design (Fig.1).

## FIELDWORK: Tabarca Island

The subsequent phase of the program involved on-site activities on Tabarca Island (Fig.2). Participants were organized into four interdisciplinary working groups, each tasked with developing sustainable proposals for the island's future. While these groups integrated students from all participating institutions to promote international collaboration, each was led by faculty from a specific university to emphasize distinct academic approaches to shared challenges:

- German Team: Focused on reconstructing visual narratives of ecosystems that have ceased to exist, revealing subtle environmental transformations that have occurred over time.



Fig.2 - Fieldwork: Tabarca Island.



- Belgian and French Team: Utilized detailed drawing techniques to explore the boundaries between human and non-human environments, fostering new dialogues and envisioning future opportunities for coexistence.

- Norwegian Team: Employed illustrated narratives and animations to investigate the interplay between liquid and solid states, emphasizing dynamic ecological relationships.

- Alicante Team: Developed A Planetary Indigestion, an immersive audio guide that highlighted Tabarca's infrastructural systems, providing a novel perspective on the island's interdependencies and ecological challenges.

This collaborative framework allowed participants to address the multifaceted challenges of climate change through diverse methodologies, generating holistic and innovative solutions for sustainable development.

## A PLANETARY INDIGESTION

Directed by professors from the University of Alicante, Javier Sánchez Merina and Joaquín Alvado, this workshop was conceived as part of an interdisciplinary initiative to underscore the critical importance of water as a vital resource and to investigate innovative interactions with Tabarca Island's unique environment.

### Student Participants:

- Sunny Angelina Geschwender, KIT
- Cara Francine Stiller, KIT
- Élodie Lebon, ENSAM Réunion



Fig.3 - Explanation on the possibilities of water technology, by Vicente Castillo (*Rain Bird*).

- Ferdinand Widmer, AHO
- Håkon Grundt, AHO
- Jasmin Maichle, KIT
- Jesse Kauppinen, UCLouvain
- Julian Zimmermann, KIT
- Kawtar Guennouni, UCLouvain
- Morten Midtun, AHO
- Romance Al Sous, UCLouvain
- Tatar Marian-Georgian, UCLouvain

Additionally, participants benefited from the guidance *Visiting Professors*:

- Maria Luna Nobile, Umeå Univ.
- Maria Hadjisoteriou, Univ. Nicosia
- Maria José Marcos, Alicante Univ.
- Francisco Leyva, Alicante Univ.

The workshop was led by *La Cuarta Piel*, a renowned collective of architects and artists celebrated for their groundbreaking multimedia architectural projects, the experience began with a

custom-designed audio tour. This immersive journey around the island highlighted the central theme of water, establishing a foundational framework for creative exploration.

## DAY 1: Establishing Foundations

The workshop commenced with an emphasis on the theme of water, drawing inspiration from the intrinsic relationship between Tabarca Island and this precious element. With sponsorship from *Rain Bird*, a prominent manufacturer of irrigation systems, participants were provided with materials such as pipes and other supplies essential to their explorations (Fig.3).

The initial brainstorming and

creative experimentation unfolded in Plaza Carlfred, where the first concept emerged: to activate and transform the plaza using water-related elements and sound. This setting became the epicentre of collaborative experimentation and idea generation throughout the workshop.

Within the plaza, participants formed several groups to address diverse creative challenges. One group focused on crafting suspended water tanks between trees, producing visually striking installations that embodied the theme of water. Another group explored the sonic qualities of water, conducting experiments with liquid-generated sounds. Meanwhile, a third team designed an artificial cloud utilizing irrigation pipes, further diversifying the workshop's artistic interpretations of the central theme.

## DAY 2: Refining Ideas and Expanding Horizons

On the second day, participants divided into three specialized groups to develop their projects

further. One group concentrated on narrative development, refining the audio experience. Another team worked on sound recording and interviews to deepen their understanding of the island's complex relationship with water. The third group continued their work on the cloud installation.

As work progressed, a novel idea emerged: integrating the artificial cloud into a large fig tree located in another plaza.

This conceptual shift involved merging fiction with reality, transforming the installation into an artistic illusion where the tree itself appeared to produce rain. The resulting display fused natural and artificial elements, creating a captivating spectacle that blurred the boundaries between art and ecology.

## DAY 3: Consolidating Components and Presenting Themes

By the third day, all project components—including the "raining tree"—were integrated into a cohesive audio guide designed to provide an immersive experience

of the workshop's water-related explorations (Fig.4).

A significant addition was a new installation at the endpoint of the wastewater pipe that channels treated water away from the island.

This installation symbolized the culmination of the participants' observations, encapsulating the island's sustainable water management practices.

Students meticulously tested and arranged elements of the audio guide to ensure a seamless and impactful presentation.

This phase represented a convergence of creativity, technical skill, and ecological awareness, culminating in a compelling exploration of Tabarca Island's intricate relationship with water.

## DAY 4: Guided Tour and Public Engagement

On the fourth day, a guided tour of the island was conducted for all workshop participants and residents (Fig.5 and 6). The audio experience diverged from conventional



Fig.4 - The Raining Tree.



Fig.5 - Invitation to a pass of A Planetary Indigestion.



Fig.6 - Frames from the video A Planetary Indigestion, recorded during the audio-guided tour of Tabarca Island.



tourist guides by illuminating the island's hidden infrastructures: the port where daily waste is transported, the supply chain for goods, the freshwater reservoir, the wastewater treatment plant, and the quarry access point. These stops offered an alternative perspective on the island's operational realities.

According to *La Cuarta Piel*, "while Tabarca has aspired to self-sufficiency at various points in its history, it now heavily depends on external services for waste management, resource supply, and tourism. Making this reality visible is critical to fostering collective awareness and addressing ecological challenges collaboratively." This interdependence, common to urban contexts but particularly acute in Tabarca, is managed through technologies such as wastewater treatment plants, irrigation systems, and maritime transport.

These often-overlooked

infrastructures demand societal reflection and active participation. "Highlighting the significance of these systems and understanding their implications is essential to collectively confront the ecological challenges we face today."

Finally, the project invited participants to reflect on water's perspective, metaphorically giving voice to the element itself to articulate its role and feelings about the collaborative exploration:

*In silence deep, beneath the azure gleam,  
I, water, weave through Tabarca's dream.  
A whispered current, unseen and untamed,  
Bound by pipes, my essence reclaimed.*

*From earth's embrace, I rise to the day,  
An island's heartbeat, life's gentle ballet.  
Enveloped by the sea's embrace,  
I am the unseen thread, the island's grace.*

*Yet through the hands of curious minds,  
I am awakened, in new forms entwined.*

*A workshop's touch, a daring quest,  
To reveal my secrets, to manifest.*

*In Plaza Carlfred's ancient domain,  
They gathered, souls ripe with refrain,  
To conjure sounds, to conjure sights,  
From hidden conduits, my ancient rites.  
A cloud of pipes, a dance of spray,  
A moment born from the workshop's sway.  
Their hands, like whispers on my skin,  
Unveiled the melody I hold within.*

*Then a voice arose, a spectral guide,  
A journey scripted, a lyrical tide,  
That spoke of me, my ebb and flow,  
In harmonies that only water knows.*

*And deeper still, a rainbow's arc,  
Projected through me, a radiant spark,  
Beneath the sun's benevolent gaze,  
A spectacle woven in the workshop's maze.*

*So water speaks, through pipes and song,  
Invisible currents, ancient and strong.  
Though used, transformed, I remain  
serene,*

*A witness to the artist's hopeful sheen.*

## DAY 5: A Closing Tribute

Following *La Cuarta Piel's* departure on the fifth day, the participants expressed their gratitude through a symbolic gesture. Utilizing the workshop's central material—pipes—they crafted a portable cloud installation. Carried collectively, the installation emitted water when positioned against sunlight, creating a radiant rainbow (Fig.7). This final act encapsulated the workshop's essence, celebrating collaboration, creativity, and ecological consciousness while leaving an indelible mark on the collective experience at Tabarca Island.

## CONCLUSION

The immersive teaching methodology employed in this program, which involved living and working within an unfamiliar

context, successfully stimulated students' curiosity and motivated them to explore and discover independently. Tabarca Island, often perceived as an idyllic natural environment, exemplifies a utopian vision that is, in fact, artificially sustained by three essential conduits from the mainland: a freshwater pipeline, a sewage pipeline, and an electricity cable. Without these infrastructural links, the iconic image of Tabarca as a pristine haven would not be feasible.

As a tangible outcome of the workshop, Tabarca now features an audio guide centered on its ecological interdependencies, aiming to foster a sense of attachment and care for the environments we inhabit (Fig.8). The guide highlights several pressing issues: the significant quantities of food waste and garbage that must be transported daily to the mainland, the loss of species that

once thrived on the island, and changes to the island's porosity due to recent constructions. These elements collectively illustrate the evolving relationships between human and non-human agents.

By rendering visible the otherwise invisible processes and transformations that have shaped Tabarca over the years, the students have posed an important question: should the challenge now be to reimagine the island as self-sufficient? Historically, Tabarca was designed for self-reliance, with its preserved agricultural land and numerous wells for water storage as key features of its sustainability. The students' final project, a traveling rainbow installation, serves as a powerful demonstration of technique and imagination. It symbolizes the potential for alternative realities, where creativity and innovation can address contemporary ecological challenges while fostering a deeper connection with the natural world.



Fig.7 - Constructing Rainbows.



Fig.8 - Qr codes of Tabarca Video and Audio Guide *A Planetary Indigestion*.



# UOU scientific journal

## Issue #09 / IN PRESENCE

### June 2025

#### Guest Editors

Marco Bovati / Politecnico di Milano, Italy

Anna Moro / Politecnico di Milano, Italy

Daniele Villa / Politecnico di Milano, Italy

25 November 2024

Call opens.

15 January 2025

Full paper submission.

21 February 2025

Outcome of double-blind peer review process.

15 March 2025

Final submission of completed papers.

**IN PRESENCE** This Call is directed at researchers and professionals in the fields of spatial studies, from architecture to urban and environmental design, planning and policies, as well as artistic disciplines and experimental practices. It invites them to reflect on the conditions, practices, and tools that require the presence of a body - or multiple bodies - in a space, whether small or large, indoor or outdoor, to be authentically lived, experienced and realised. It further asks how the embodied practices differ from, and why they may be crucial compared to, technologically mediated, non-corporal, immaterial, or even non-human experiences, delving into the tapestry of this relationship within five thematic areas:

CONCEIVED  
INTER-ACTIVE  
AFFECTED  
VULNERABLE  
AUGMENTED

More information:

<https://revistes.ua.es/uou>

UOU is the scientific journal of **UNIVERSITY of Universities**. It is born out of the collaboration of international schools of architecture, sharing their intercultural interests.

Every issue underlines a specific topic addressed by one of the universities involved in the Research Project, with a focus on Pedagogy in Architecture.

# IN PRESENCE

UOU Scientific Journal  
Issue #09 June 2025  
ISSN: 2697-1518  
DOI: 10.14198/UOU.2025.9

Journal #09 UOU scientific journal #09  
UOU scientific journal #09 UOU scie



